



Product Specification Sheet

EK-Mosfet 790i Part 2

EAN / Part #: 3830046992178

Copper Plexi

Copper Acetal

Nickel Plexi

Nickel Acetal

Summary:

- Featuring a unique, modern look copper design High performance mosfet water block for EVGA 790i motherboards.
- An extreme high flow path design and unique increased cooling surface over VREG's keeps chips cool even at highest loads and over clock.
- Blocks base is made of SE CU electrolytic copper.
- Top is made of high quality acrylic.
- High quality CNC manufacturing.
- Leak tested to 2 bar pressure (30psi).

Key Features:

- Real high flow internal design gives minimum flow restriction which allows lowest possible temperatures in the entire water-cooling system.
- Reduces temperatures up to 30°C or even more at maximum load.
- Much cooler components, allow maximum possible overclocking.

Technical data:

- dimensions of copper base: 65x21x3,5mm
- dimensions of acetal top: 65x21x17,5mm
- threads: 2 x G 1/4
- fittings: optional, not enclosed
- neto weight: 85g
- bruto weight: 100g

Packing list:

- 1 x Water block
- Mounting mechanism

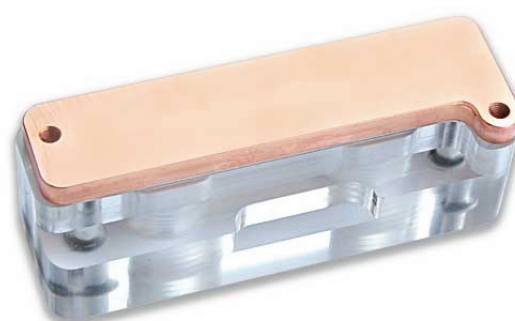

Do not forget other EK products for your water cooling system:



blocks



radiators



pumps



resevoirs



accessories

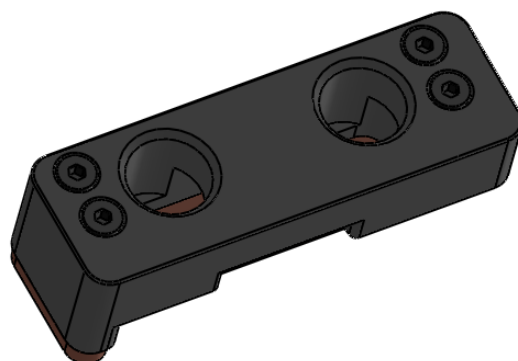
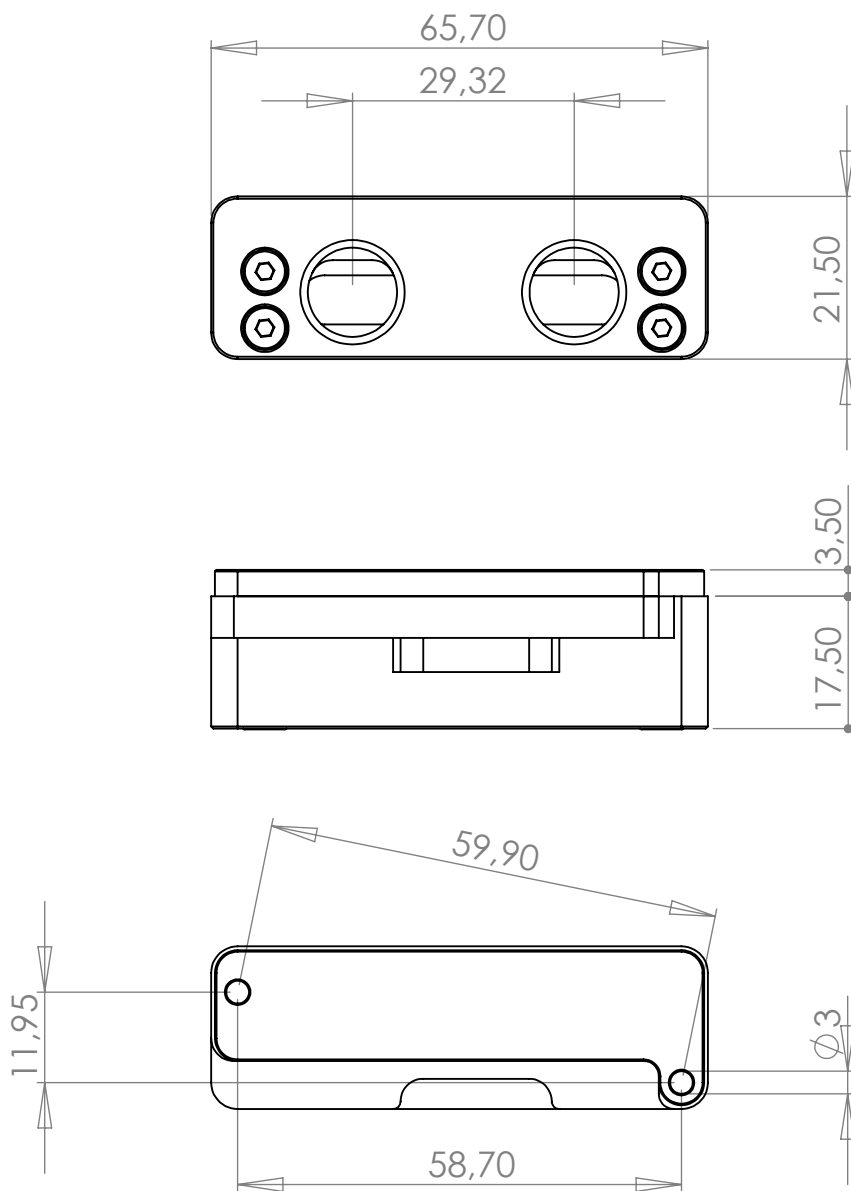

IMPORTANT DISCLOSURE: Drawing is copyrighted and property of EKWB d.o.o. company. Drawing is supplied only for easier compatibility recognition by user and can not be used for any other intention.



PRODUCT NAME: **EK-MOSFET 790i PART2**

Scale: **1:1**

Sheet format A4

Sheet 1 of 1