



## Product Specification Sheet

# EK-NB ASUS HP

EAN / Part #: 3830046991331

Copper Plexi

Copper Acetal

Nickel Plexi

Nickel Acetal

### Summary:

- Featuring a unique, modern look copper design High performance chipset water block mounted on stock Heatpipe system of ASUS RAMPAGE EXTREME AND MAXIMUS II (2) FORMULA motherboards.
- EK chipset series water blocks cover chips that require cooling if overclocked.
- An extreme high flow path design and unique increased cooling surface over Northbridge keeps chips cool even at highest loads and over clock.
- Blocks base is made of SE CU electrolytic copper.
- High quality CNC manufacturing.
- Leak tested to 2 bar pressure (30psi).

### Key Features:

- Real high flow internal design gives minimum flow restriction which allows lowest possible temperatures in the entire water-cooling system.
- Reduces temperatures up to 50°C or even more at maximum load.
- Much cooler components, allow maximum possible overclocking.

### Technical data:

- dimensions of copper base: 36x36x5,5mm
- dimensions of acrylic top: 50x39x7,8mm
- threads: 2 x G 1/4
- fittings: optional, not enclosed
- neto weight: 55g
- bruto weight: 110g

### Packing list:

- 1 x Water block
- Mounting mechanism

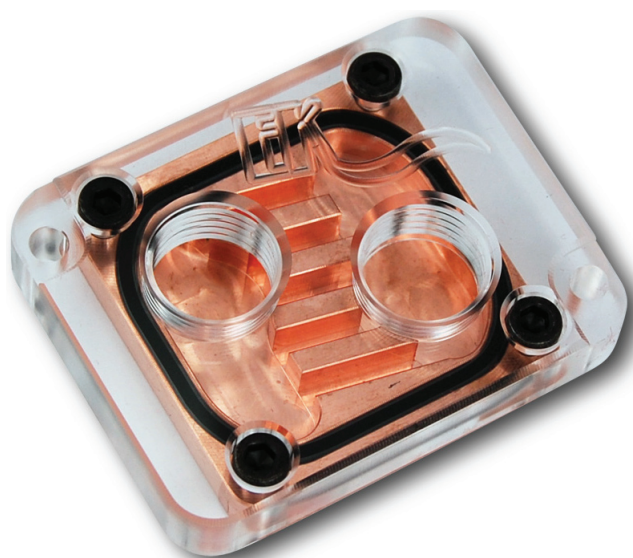

Do not forget other EK products for your water cooling system:



blocks



radiators



pumps



resevoirs



accessories

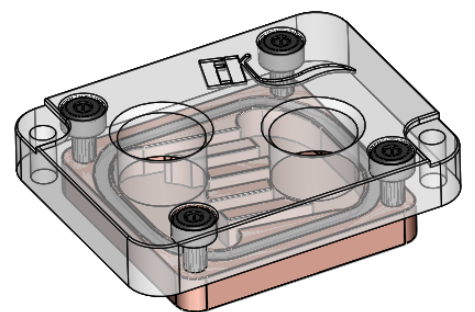
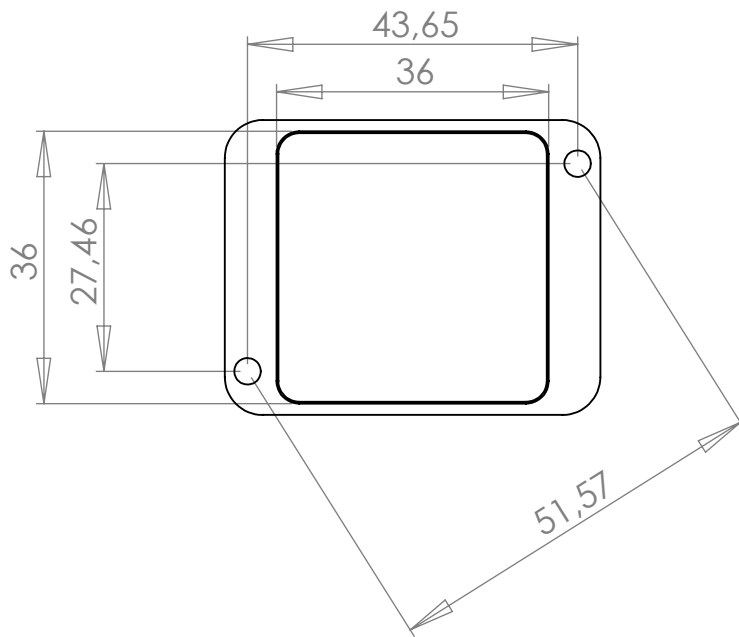
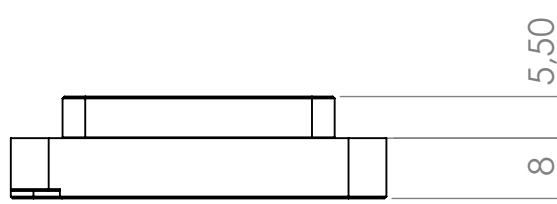
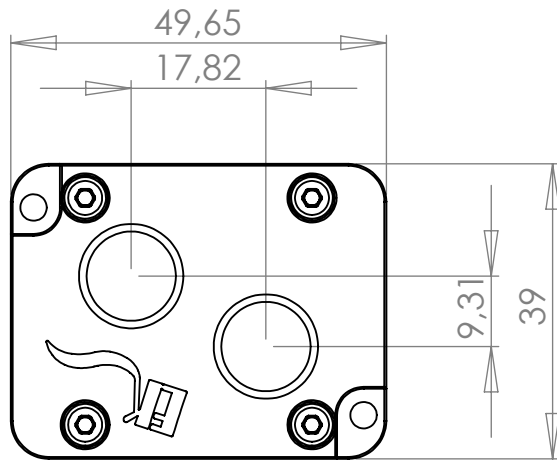

**IMPORTANT DISCLOSURE:** Drawing is copyrighted and property of EKWB d.o.o. company. Drawing is supplied only for easier compatibility recognition by user and can not be used for any other intention.



PRODUCT NAME: **EK- ASUS HP**

Scale: **1:1**

Sheet format A4

Sheet 1 of 1