

# EK-PRO GPU RTX PRO 6000 SE

GPU WATER BLOCK

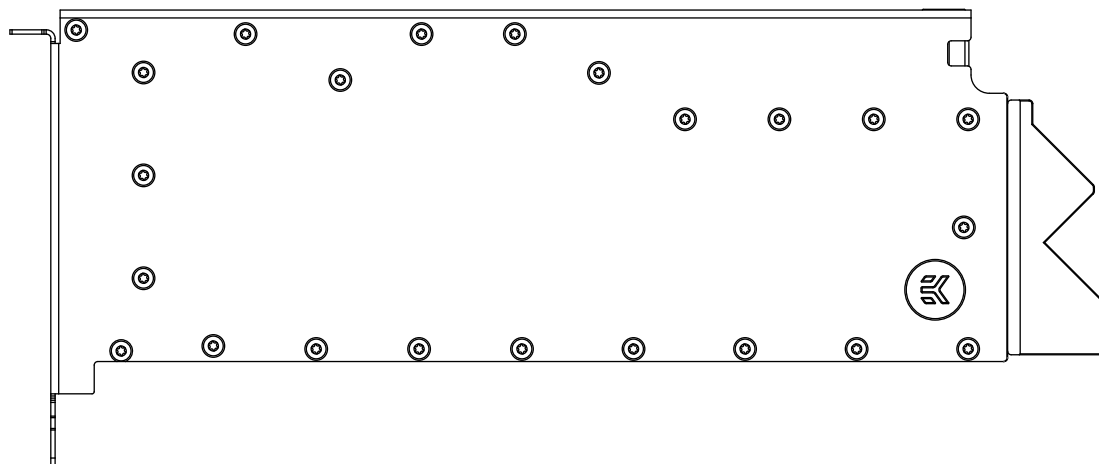

This product is intended for installation only by expert users. Please consult with a qualified technician for installation. Improper installation may result in damage to your equipment. EK Water Blocks assumes no liability whatsoever, expressed or implied, for the use of these products, nor their installation. The following instructions are subject to change without notice. Please visit our website at [www.ekwb.com](http://www.ekwb.com) for updates. Before installation of this product, please read important notice, disclosure, and warranty conditions that are printed on the back of the box.

Before you start using this product, please follow these basic guidelines:

**Please carefully read the manual before beginning the installation process.**

**The EK Fittings require only a small amount of force to screw them firmly in place since the liquid seal is ensured by the rubber O-ring gaskets.**

**The use of corrosion inhibiting coolants is always recommended for liquid cooling systems, and mandatory for nickel plated water blocks.**

**Do not use pure distilled water! For best results EK recommends the use of EK-Cryo Fuel coolants.**

**Make sure to thoroughly bleed air out of your water block, or you will not reach optimal performance.**

# TABLE OF CONTENTS

<b>BOX CONTENTS .....</b>	<b>4</b>
<b>WATER BLOCK DIMENSIONS.....</b>	<b>5</b>
<b>TECHNICAL SPECIFICATIONS AND WATER BLOCK PARTS .....</b>	<b>6</b>
<b>PREPARING THE GRAPHIC CARD .....</b>	<b>7</b>
<b>CUTTING AND PLACING THERMAL PADS - WATER BLOCK.....</b>	<b>8</b>
<b>APPLYING THERMAL COMPOUND .....</b>	<b>10</b>
<b>ATTACHING THE WATER BLOCK .....</b>	<b>10</b>
<b>CUTTING AND PLACING THERMAL PADS - BACKPLATE.....</b>	<b>12</b>
<b>ATTACHING THE BACKPLATE.....</b>	<b>13</b>
<b>INSERTING THE GRAPHICS CARD INTO THE CHASSIS.....</b>	<b>14</b>
<b>CHECKING THE CONTACT IN CASE OF HIGH TEMPERATURES .....</b>	<b>14</b>
<b>TESTING THE LOOP.....</b>	<b>15</b>
<b>WARRANTY .....</b>	<b>15</b>
<b>SUPPORT AND SERVICE.....</b>	<b>16</b>

# BOX CONTENTS

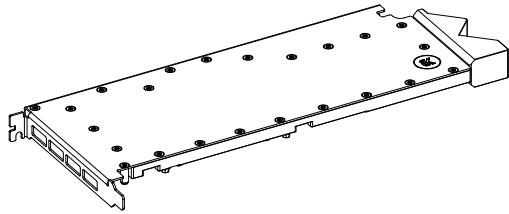

EK-PRO GPU RTX PRO 6000 SE

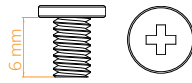

M2.5x6 AX1 Screw  
(6 pcs)

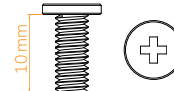

M2.5x10 AX1  
(11 pcs)

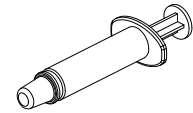

Thermal Paste (1 pc)

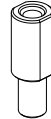

GPU Bracket Standoff  
M4-6/32 (1 pc)

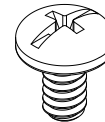

Screw UNC 6/32x5 (1 pc)



Allen Key 2mm (1 pc)

EAN: 108745

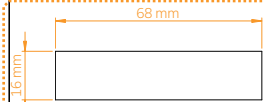

Thermal Pad - VRAM  
68x16x2 (4 pcs)



Thermal Pad - VRAM  
55x16x2 (2 pcs)

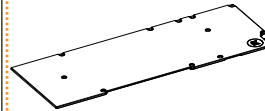

Backplate (1 pc)

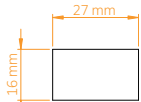

Thermal Pad - VRAM  
27x16x2 (2 pcs)

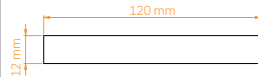

Thermal Pad - Inductor  
120x12x1 (2,5 pcs)

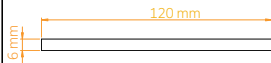

Thermal Pad -VRM  
120x6x2 (2,5 pcs)

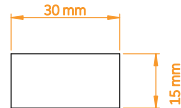

Thermal Pad BP Chip  
30x15x3 (1 pc)

EAN: 108744

# WATER BLOCK DIMENSIONS

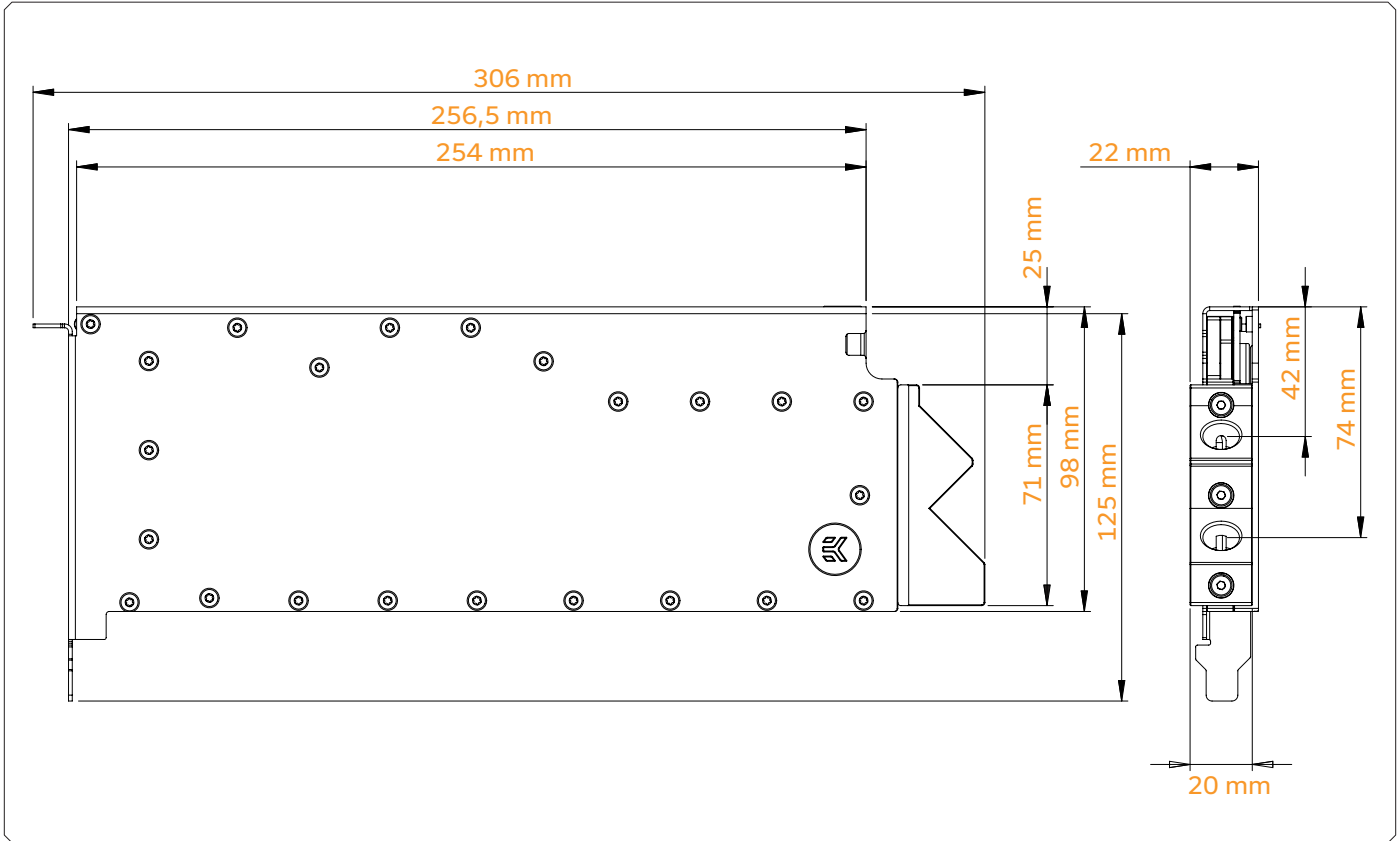

## TECHNICAL SPECIFICATIONS AND WATER BLOCK PARTS

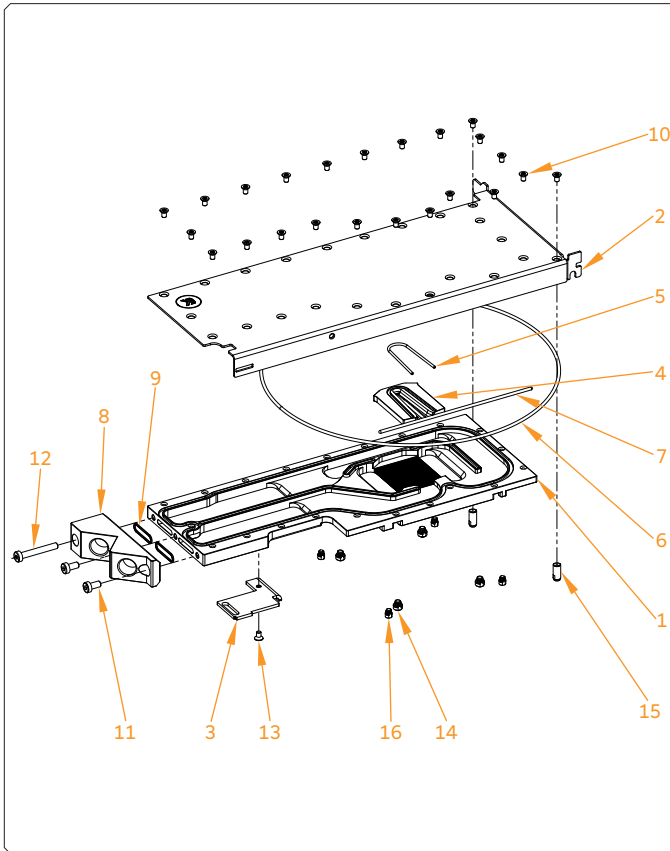

Pos.	EAN	Description	Qty.
1	108544	Pro GPU RTX PRO 6000 SE Coldplate (Ni)	1
2	108545	Pro GPU RTX PRO 6000 - Top	1
3	107037	Power Adapter Bracket	1
4	107968	Plexi Insert D4	1
5	107994	OR - Jet Insert - Vector3 RTX 50X0	1
6	108546	OR 195x2 mm EPDM70	1
7	5074	OR 2 mm EPDM70	1
8	106439	Top Acetal - Pro Terminal GPU 45 deg	1
9	5155	OR 15x1 EPDM50 (FC Terminal)	2
10	103089	Screw M3x5 ISO 14581 TX	23
11	9013	Screw M4x8 DIN7984	2
12	8323	Screw M4x28 DIN7984	1
13	100304	Screw M3x5 DIN7991 INOX	1
14	108005	Standoff M4-M2 x 3 mm	4
15	108434	Standoff M3-M2,5 x 11,3 mm	2
16	103987	Standoff M3,5-M2,5 x 3 mm	4

## PREPARING THE GRAPHIC CARD

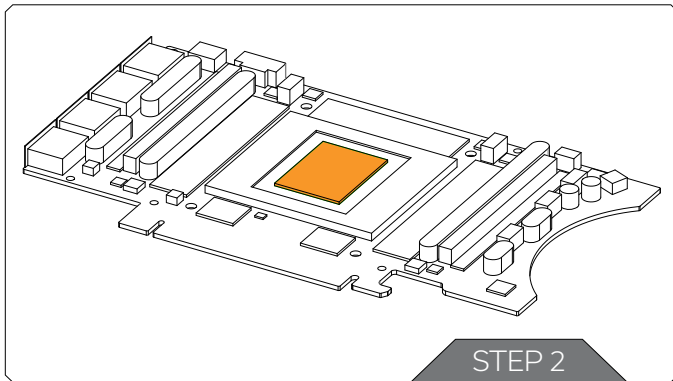

### STEP 1

#### REMOVING THE STOCK COOLER



**Important!** Before starting, make sure to have a clean, flat surface to work on. It is recommended to put foam or soft material to lay the graphics card on.

Place your graphics card on the flat surface and carefully remove the stock cooler. Do not forget to unplug all the LED and fan connectors. Pay attention to the following steps in order to install the **EK-Pro GPU WB RTX PRO 6000 SE** block onto the graphics card.

### STEP 2

#### CLEANING THE PCB

Wipe off the remains of the original thermal compound using a nonabrasive cloth or Q-tip, as shown in the sample image, until the components and circuit board are completely clean. EK recommends the use of denatured alcohol for removing TIM leftovers. After that, remove all remaining stock thermal pads from the PCB.

# CUTTING AND PLACING THERMAL PADS - WATER BLOCK

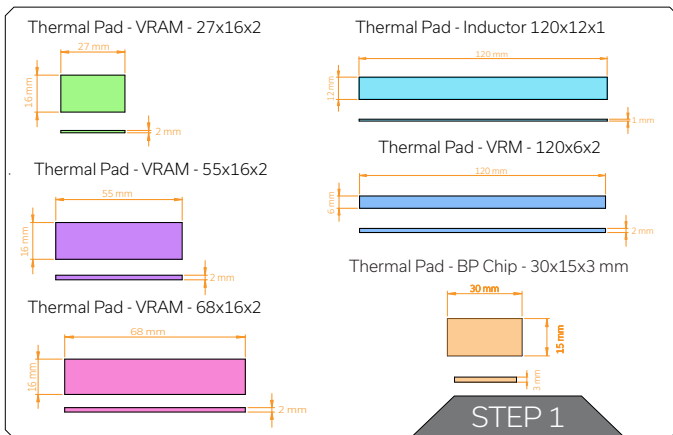

## STEP 1

The GPU water block comes with pre-cut thermal pads, but some of them need to be additionally cut into smaller pieces.

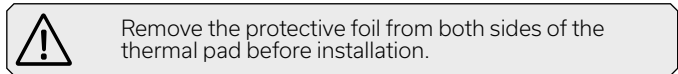

Replacement thermal pads (EAN 108744):

- Thermal Pad - VRAM - 68x16x2 mm - 4 pcs
- Thermal Pad - VRAM - 55x16x2 mm - 2 pc
- Thermal Pad - VRAM - 27x16x2 mm - 2pc
- Thermal Pad - Inductor - 120x12x1 mm - 2,5 pcs
- Thermal Pad - VRM - 120x6x2 mm - 2,5 pcs
- Thermal Pad - BP Chip - 30x15x3 mm - 1 pcs

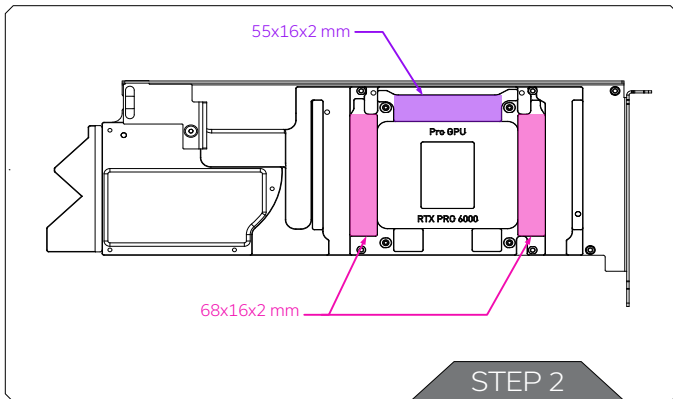

## STEP 2

Use two (2) Thermal Pad - VRAM - 68x16x2 mm

Thermal Pad - VRAM - 68x16x2

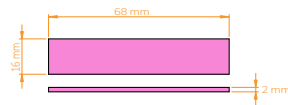

Use one (1) Thermal Pad - VRAM - 55x16x2 mm

Thermal Pad - VRAM - 55x16x2

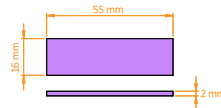

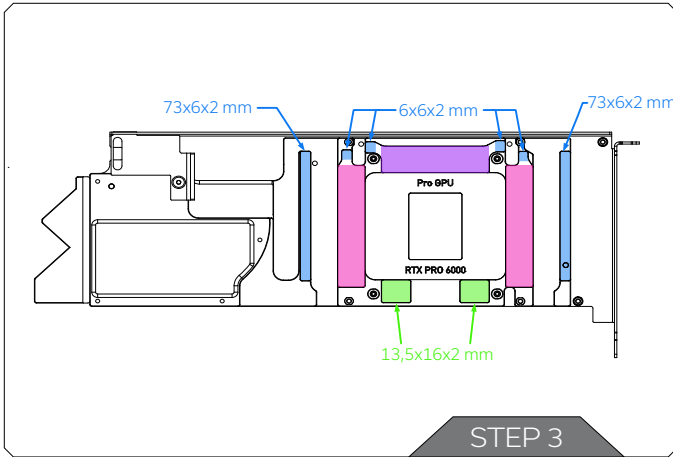

### STEP 3

Use one (1) Thermal Pad - VRAM - 27x16x2 mm

Cut it in half (13,5x16 mm)

Thermal Pad - VRAM - 27x16x2

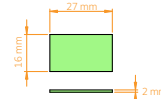

Use two (2) Thermal Pad - VRM - 120x6x2 mm

Cut two (2) to a length of 73 mm.

Cut remaining Thermal Pad - VRM - 120x6x2 mm to a 6mm length (4 pcs).

Thermal Pad - VRM - 120x6x2

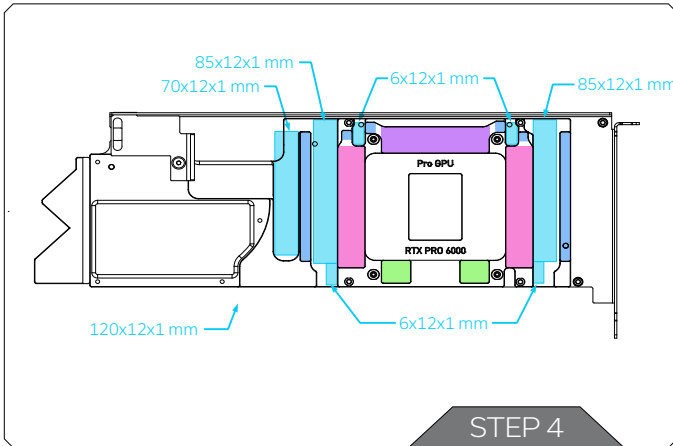
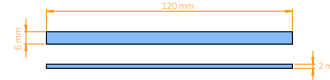

### STEP 4

Use two (2) pcs of Thermal Pad - Inductor - 120x12x1 mm.

Use 0,5 pcs of Thermal Pad - Inductor - 120x12x1 mm.

Cut it to 6 pcs: 8x12x1 mm

Thermal Pad - Inductor 120x12x1



## APPLYING THERMAL COMPOUND

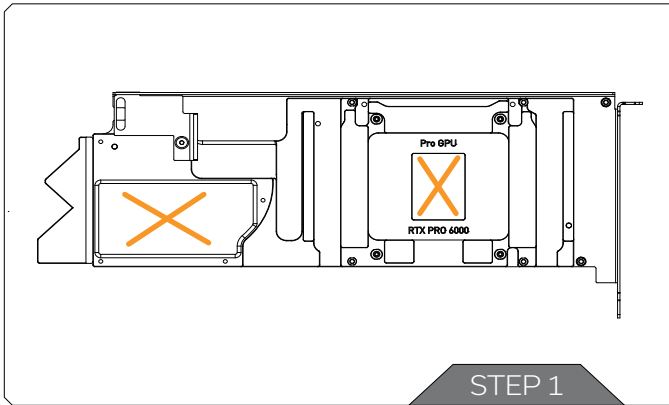

### STEP 1

Apply the enclosed thermal paste (thermal compound) on the GPU die – as shown in the image. The layer of the thermal compound must be thin and even over the entire die surface.



The excessive or uneven application of thermal grease may lead to poor performance!

For this step, you will need:

Thermal Grease

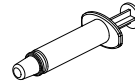

## ATTACHING THE WATER BLOCK

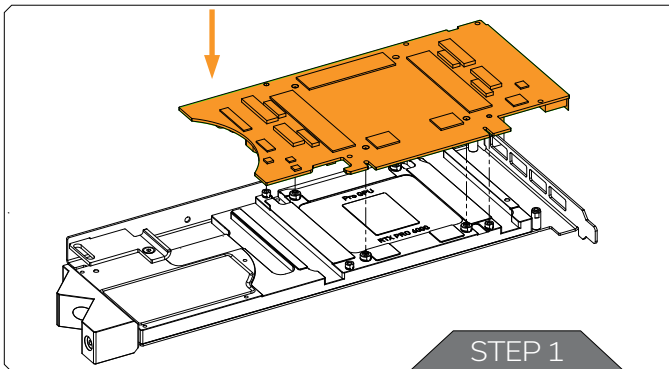

### STEP 1

Carefully position the PCB on the water block. During this process, make sure you have aligned the mounting holes of the PCB with the holes of the water block.



Pay attention not to use too much force when pressing the PCB down to the block since chip dies are prone to cracking.



Before attaching the PCB to the Water Block, make sure all the Thermal Pads are placed correctly!

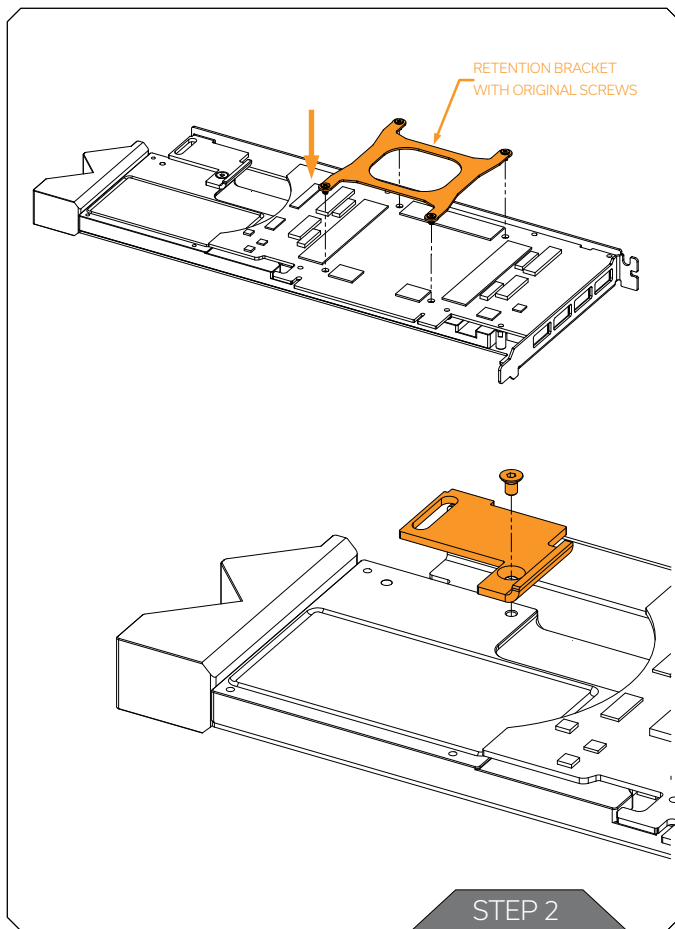

## STEP 2

Carefully align the retention bracket onto the water block and tighten four (4) original screws in a criss-cross pattern.

It is recommended to partially screw in all the screws first, then tighten them evenly using a Phillips head screwdriver.

For this step, you will need:

Phillips Head  
Screwdriver

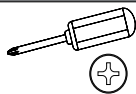

Secure power cable with mounting it into included inox power adapter.

Insert power connector in to the inox adapter. Pads on the power adapter must be aligned with openings in inox power adapter.

Pay attention to the orientation of the latch on connector.

For this step, you will need:

Allen Key  
2mm

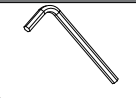

# CUTTING AND PLACING THERMAL PADS - BACKPLATE

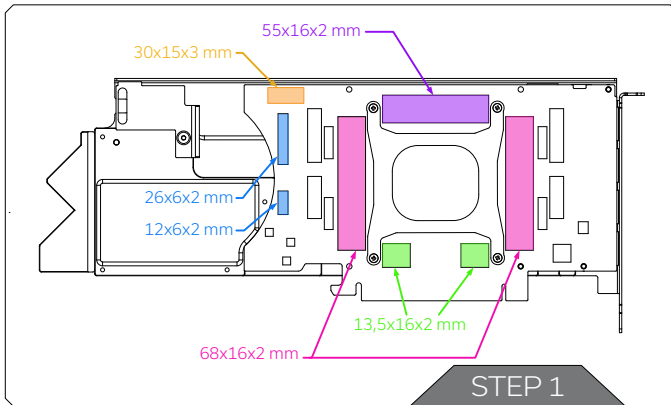

## STEP 1

Use two (2) Thermal Pad - VRAM - 68x16x2 mm

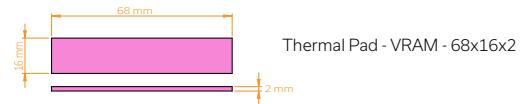

Use one (1) Thermal Pad - VRAM - 55x16x2 mm

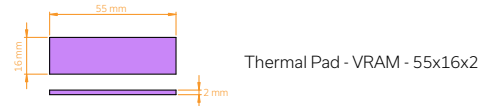

Use one (1) Thermal Pad - VRAM - 27x16x2 mm  
Cut it in half (13,5x16 mm)



Use Thermal Pad - VRM - 120x6x2 mm

Cut one (1) to a length of 26 mm.

Cut one (1) to a length of 12 mm.

Thermal Pad - VRM - 120x6x2

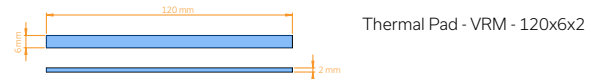

Use Thermal Pad - BP Chip- 30x15x3 mm

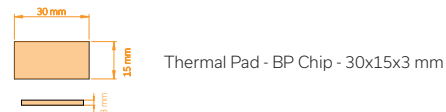

## ATTACHING THE BACKPLATE

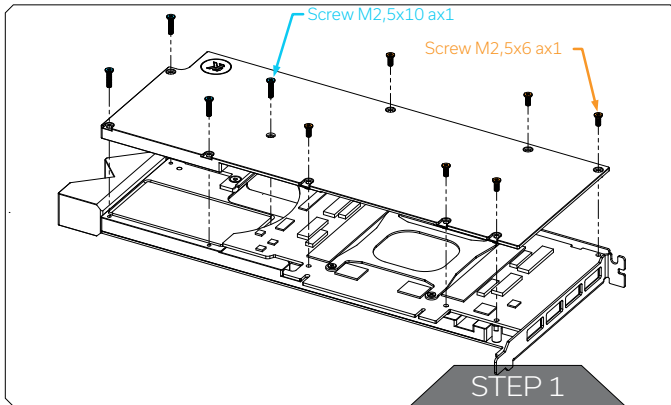

### STEP 1

Position the Backplate onto the GPU PCB. Make sure all the holes are aligned.

Use four (4) M2,5x10 ax1 and six (6) M2,5x6 ax1 screws.

Tighten the screws evenly.

Do not use excessive force!

For this step, you will need:

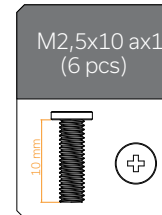
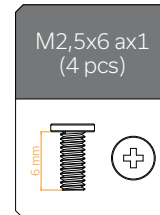

## CHECKING THE CONTACT IN CASE OF HIGH TEMPERATURES

If necessary, temporarily remove the water block to check for uniform surface contact between the block and components. Pay special attention to the VRM section of the graphics card. Check whether the water block makes contact with the intended integrated circuit. Then repeat Steps from the previous section to re-attach the block.



In case you fail to obtain good contact, please check again or contact our support service at <https://www.ekwb.com/customer-support/>.

## INSERTING THE GRAPHICS CARD INTO THE CHASSIS

Carefully lift your graphics card with the installed water block and insert it into your PC's motherboard PCI Express expansion slot. Please keep in mind that your graphics card is heavier than before it was equipped with the water block.



You need to be very careful when handling the graphics card. Avoid all unnecessary manipulation of the water block assembly that might damage your card or water block.

## TESTING THE LOOP

To make sure the installation of EK components was successful, we recommend you perform a leak test for 24 hours. When your loop is complete and filled with coolant, connect the pump to a PSU outside of your system. Do not connect power to any of the other components. Turn on the PSU and let the pump run continuously. It is normal for the coolant level to drop during this process as air collects in the distribution plate. Inspect all parts of the loop, and in the eventuality, that coolant leaks, fix the issue and repeat the testing process. Ensure that all hardware is dry before the system is powered on in order to prevent any damage.

## WARRANTY

Our products are warranted against defects of materials and quality for a period of 24 months, starting with the date of delivery to the end-user. During this period, products will be repaired or have parts replaced at our discretion, provided that 1) the product is returned to the agent from whom it was purchased; 2) the product has been purchased by the end-user and has not been used for commercial purposes; 3) the product has not been misused, handled carelessly, or used in a manner other than the way described in the instructions manual. This warranty does not confer rights other than those expressly set out above and does not cover any claims for consequential loss or damage. This warranty is offered as an extra benefit and does not affect your statutory rights as a consumer. This warranty is voided if the product comes in contact with aggressive UV additives or other improper liquids. EK water blocks are sealed with a warranty-voiding circular label, proving the water block has withstood a pressure leak test. Removing the label will void the leak-free guarantee, but not the guarantee on the product itself. Any other RMA issues can be reported to EK Customer Support at [www.ekwb.com/support](http://www.ekwb.com/support) for further analysis.

## SUPPORT AND SERVICE

In case you need assistance or wish to order spare parts or a new mounting mechanism, please contact:

**<https://www.ekwb.com/customer-support/>**

For spare parts orders, refer to the page with "TECHNICAL SPECIFICATIONS AND WATER BLOCK PARTS" where you can find the EAN number of each part you might need.

Include the EAN number with quantity in your request. Mounting Mechanism EAN can be found under "BOX CONTENTS"

Thermal pads are readily available in the EKshop

## SOCIAL MEDIA

 EKbyLMTEK

 @EKbyLMTEK

 ekwaterblocks

 @EKbyLMTEK

 LM TEK (The Home of EK)

