

EK-Loop Thermal Paste NGP





General information

Carefully read the manual before beginning with the installation process.

The Safety Data Sheet is available on the product webpage.

Warnings and information notices provide important information for hazard-free operations.

The product is used solely for the application of thermal paste.



Safety precaution

Use personal protective equipment. Always wear eye and skin protection.

Keep the product away from children!

Description of first aid measures	
General advice	Immediate medical attention is required. Show the safety data sheet (SDS) to the doctor in attendance. The Safety Data Sheet is available on the product webpage.
Eye contact	First, rinse with plenty of water for several minutes (remove contact lenses if easily possible), then take to a doctor.
Skin contact	Rinse skin with plenty of water or shower.
Ingestion	Rinse mouth.
Inhalation	Fresh air, rest.
Protecting of first-aiders	Ensure that medical personnel is aware of the substance involved. Take precautions to protect themselves and prevent the spread of contamination.

TABLE OF CONTENTS

APPLYING THE THERMAL COMPOUND (APPLICATION ON THE CPU)	4
APPLYING THE THERMAL COMPOUND (APPLICATION ON THE GPU)	5
STORAGE CONDITIONS AND RECYCLING	6
SUPPORT AND SERVICE	7
SOCIAL MEDIA	7
TECHNICAL DATA SHEET	8
SAFETY DATA SHEET	9

APPLYING THE THERMAL COMPOUND (APPLICATION ON THE CPU)

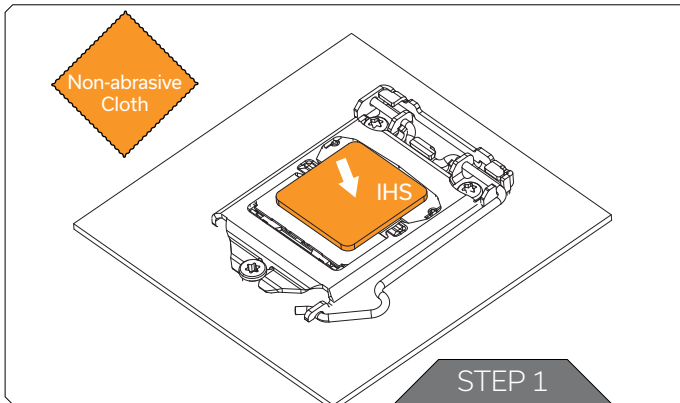

STEP 1

If already installed, please remove the motherboard from your computer and place it on an even surface. Wipe the CPU IHS clean using a non-abrasive cloth or Q-tip.

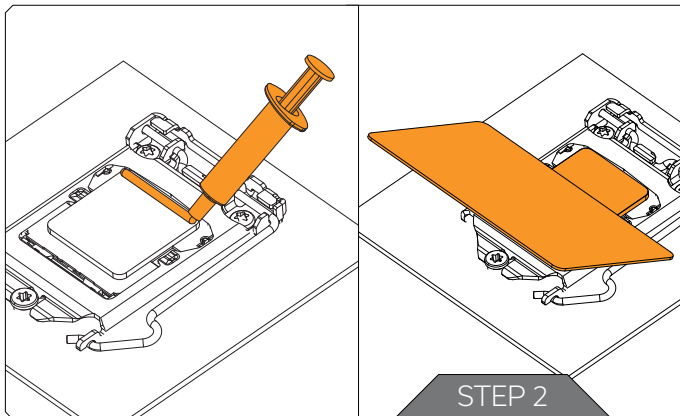

STEP 2

Once clean, apply a line of Thermal Compound on one edge of the IHS and use a credit card or similar to spread it evenly. The layer of Thermal Compound must be thin and even in thickness over the entire surface of the IHS. Excessive or irregular application may lead to poor performance.

APPLYING THE THERMAL COMPOUND (APPLICATION ON THE GPU)

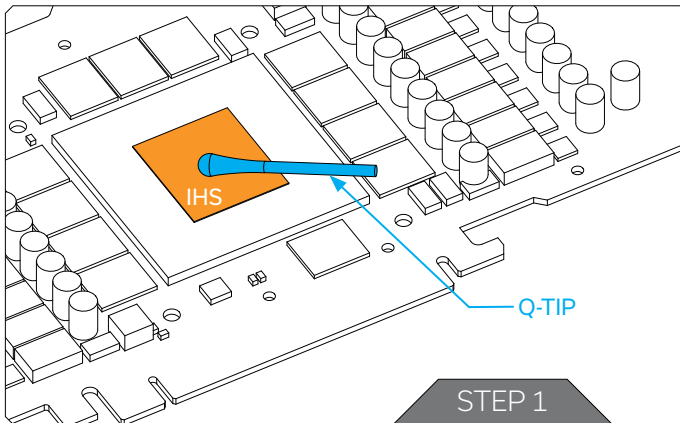

STEP 1

If already installed, please remove the graphics card from your computer and place it on an even surface. Wipe the GPU IHS clean using a non-abrasive cloth or Q-tip.

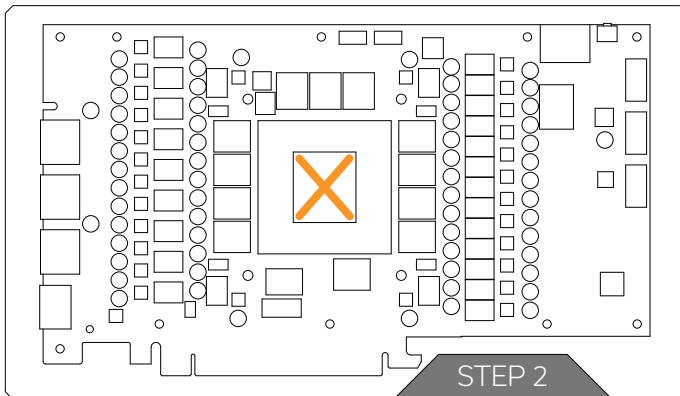

STEP 2

Apply the enclosed thermal grease (thermal compound) on the GPU heat spreader - IHS. The layer of the thermal compound must be thin and even over the entire surface of the IHS.

STORAGE CONDITIONS AND RECYCLING

EK-Loop Thermal Paste NGP should be stored in its original packaging at room temperature(ideally 20 - 22°C) in dry rooms. Do not leave the packaging open after use.



Products marked with this symbol must not be disposed of with unsorted municipal waste to avoid environmental and health problems due to hazardous substances.

SUPPORT AND SERVICE

For assistance please contact:

<http://support.ekwb.com>

LM TEK d.o.o.

Pod lipami 10

1218 Komenda Slovenia - EU

SOCIAL MEDIA

 EKWaterBlocks

 @EKWaterBlocks

 ekwaterblocks

 EKWBofficial

 ekwaterblocks



EK-Loop Thermal Paste NGP

Technical Data sheet

Features & Benefit:

- Low thermal impedance
- Good thixotropy, operating easily
- Excellent Applicability
- Good crumpling resistance, high reliability in long-term work

Specification:

EK-Loop Thermal Paste NGP is a thermally conductive grease compound designed for use as a thermal interface material between the high-power electronic component and the heat sink. EK-Loop Thermal Paste NGP compound is made by nano-grade powder with very low thermal impedance and excellent applicability.

EK-Loop Thermal Paste NGP is highly stable from -20°C to 125°C, and has good dielectric properties, in addition to the good thermal conductivity, which will not produce the pressure when use.

Property	Typical Value	Test Method
Color	Gray	Visual
Volatilization Rate (24H@200°C)%	<0.5	-
Density(g/cc)	2.98	ASTM D792
Viscosity(mPa.s)	1000~2000	ASTM D2196
Continuous Using Temperature(°C)	-20~125	-
Thermal Conductivity (W/mK)	6.9	ASTM D5470
Thermal Impedance		
Thermal Impedance(°C ·cm ² /W)	0.09	ASTM D5470
Pressure (psi)	40	-

Safety Data Sheet

High Performance Thermal Paste

Version : V2.0.0.1

Report No. : A2230398978101001

Creation Date : 2023/08/14

Revision Date : 2023/08/14

*According to GB/T 17519 and GB/T 16483

1 Identification of the chemical and supplier

| Product identifier

Product Name	High Performance Thermal Paste
Synonyms	6900P
CAS No.	Not applicable
EC No.	Not applicable
Molecular Formula	Not applicable

| Recommended use of the product and restrictions on use

Relevant identified uses	Heat Dissipate.
Uses advised against	None.

| Emergency phone number

Emergency phone number	076982851419
------------------------	--------------

2 Hazard(s) identification

| Emergency overview

Liquid. Very toxic to aquatic organisms, Use appropriate container to avoid environmental contamination. May cause long-term adverse effects in the aquatic environment. Use appropriate container to avoid environmental contamination.

| Hazard classification according to GHS

Hazardous To The Aquatic Environment – Short-Term (Acute) Hazard	Category 1
Hazardous To The Aquatic Environment – Long-Term	Category 1

(Chronic) Hazard	
GHS Label elements	
Hazard pictograms	
Signal word	Warning
Hazard statements	
H400	Very toxic to aquatic life
H410	Very toxic to aquatic life with long lasting effects
Precautionary statements	
◆ Prevention	
P273	Avoid release to the environment.
◆ Response	
P391	Collect spillage.
◆ Storage	
Storage	Not applicable
◆ Disposal	
P501	Dispose of contents/container in accordance with local/regional/national/international regulations.
Hazard description	
◆ Physical and chemical hazards	
	No information available
◆ Health hazards	
Inhaled	Inhalation of the product may produce adverse health effects or irritation of the respiratory tract following discomfort.
Ingestion	Accidental ingestion of the product may be harmful to the health of the individual.
Skin Contact	Entry into the blood-stream, through, for example, cuts, abrasions or lesions, may produce systemic injury with harmful effects.
Eye	This product may cause temporary discomfort following direct contact with the eye.
◆ Environmental hazards	
	This product is very toxic to aquatic life. This product is very toxic to aquatic life with long lasting effects. Please refer to 12th chapter of SDS.
Composition/information on ingredients	
Substance/mixture	
	Mixture

Component	CAS No.	EC No.	Concentration (Volume or weight percent, %)
Aluminium	7429-90-5	231-072-3	50
Zinc oxide	1314-13-2	215-222-5	42
Liquid Polymer	68130-24-5	268-581-5	8

First-aid measures

Description of first aid measures

General advice	Immediate medical attention is required. Show this safety data sheet (SDS) to the doctor in attendance.
Eye contact	First rinse with plenty of water for several minutes (remove contact lenses if easily possible), then take to a doctor.
Skin contact	Rinse skin with plenty of water or shower.
Ingestion	Rinse mouth.
Inhalation	Fresh air, rest.
Protecting of first-aiders	Ensure that medical personnel are aware of the substance involved. Take precautions to protect themselves and prevent spread of contamination.

- 1 Most important symptoms, acute and delayed
Cumulative effects may result following exposure.

Advice for protecting the rescuer

1	Remove all sources of ignition and increase ventilation.
2	Avoid contact with skin and eyes.
3	Avoid inhalation of vapor or mist.
4	Use personal protective equipment including respirator.

Special note to the doctor

1	Treat symptomatically.
2	Symptoms may be delayed.

Fire-fighting measures

Extinguishing media

Suitable extinguishing media	Metal dust fires need to be smothered with sand, inert dry powders.
Unsuitable extinguishing media	Do not use water, CO2 or foam.

Specific hazards arising from the substance or mixture

1	Development of hazardous combustion gases or vapor possible in the event of fire.
2	Not considered a significant fire risk, however containers may burn.

Fire precautions and protective measures

1	As in any fire, wear self-contained breathing apparatus (MSHA/NIOSH approved or equivalent) and full protective gear.
---	---

2	Fight fire from a safe distance, with adequate cover.
3	Prevent fire extinguishing water from contaminating surface water or the ground water system.

Accidental release measures

| Personal precautions, protective equipment and emergency procedures

1	Use personal protective equipment, do not breathe gas/mist/vapour/spray.
2	Ensure adequate ventilation. Remove all sources of ignition. Take precautionary measures against static discharges.
3	Evacuate personnel to safe areas. Keep people away from and upwind of spill/leak.

| Environmental precautions

1	Prevent further leakage or spillage if safe to do so.
2	Discharge into the environment must be avoided.

| Methods and materials for containment and cleaning up

1	Cut off the source of the leak as much as possible.
2	Keep leaks in a ventilated place.
3	Absorb spilled material in dry sand or inert absorbent. In case of large amount of spillage, contain a spill by bunding.
4	Remove all sources of ignition. Use spark-proof tools and explosion-proof equipment.
5	Contain spillage, and then collect with an electrically protected vacuum cleaner or by wet-brushing and place in container.

Handling and storage

| Handling

1	Handling is performed in a well ventilated place.
2	Wear suitable protective equipment.
3	Avoid contact with skin and eyes.
4	Keep away from heat/sparks/open flames/ hot surfaces.

| Storage

1	Keep containers tightly closed.
2	Keep containers in a dry, cool and well-ventilated place.
3	Keep away from heat/sparks/open flames/hot surfaces.
4	Store away from incompatible materials and foodstuff containers.

Exposure controls/personal protection

| Control parameters

◆ Occupational Exposure limit values (Chemical Harmful Factors)

Component	Standard	OELs	Standard value mg/m ³	Critical adverse health effects	Remark

Zinc oxide	GBZ 2.1-2019	PC-TWA	3	metal fume fever	-
		PC-STEL			
		5			

◆ (MAC) -

Component	Standard	PC-TWA	Standard value mg/m ³	Critical adverse health effects	Remark
Aluminium	GBZ 2.1-2019	Total dust	3	Aluminum pneumoconiosis; eye damage; irritation of mucous membranes, skin	-
		Respiratory dust	-		

◆ Biological limit values

Biological limit values	No relevant regulations
-------------------------	-------------------------

◆ Monitoring methods

1	EN 14042 Workplace atmospheres. Guide for the application and use of procedures for the assessment of exposure to chemical and biological agents.
2	GBZ/T 300 series standard Determination of toxic substances in workplace air.

| Engineering controls

1	Ensure adequate ventilation, especially in confined areas.
2	Ensure that eyewash stations and safety showers are close to the workstation location.
3	Set up emergency exit and necessary risk-elimination area.
4	Handle in accordance with good industrial hygiene and safety practice.

| Personal protection equipment

General requirement	
Eye protection	Must wear appropriate safety goggles.
Hand protection	Must wear appropriate chemical protective gloves.
Respiratory protection	Must wear appropriate personal respiratory protective equipment.
Skin and body protection	Must wear appropriate chemical protective clothing and chemical resistant shoes.

■ Physical and chemical properties

| Physical and chemical properties

Appearance	Silver liquid
Odor	Odorless
Odor threshold	No information available
pH	No information available
Melting point/freezing point(°C)	No information available

Initial boiling point and boiling range(°C)	No information available
Flash point(Closed cup, °C)	No information available
Evaporation rate	No information available
Flammability	Not combustion
Upper/lower explosive limits[%(v/v)]	Upper limit : No information available ; Lower limit : No information available
Vapor pressure	No information available
Vapor density(Air = 1)	No information available
Relative density(Water=1)	No information available
Solubility	No information available
n-octanol/water partition coefficient	No information available
Auto-ignition temperature(°C)	No information available
Decomposition temperature(°C)	No information available
Viscosity	No information available

Stability and reactivity

| Stability and reactivity

Reactivity	Contact with incompatible substances can cause decomposition or other chemical reactions.
Chemical stability	Stable under proper operation and storage conditions.
Possibility of hazardous reactions	Ultrafine powder will self-ignite in the air at room temperature.
Conditions to avoid	Incompatible materials, heat, flame and spark.
Incompatible materials	Oxidants, halogen, interhalogen and mercury.
Hazardous decomposition products	Under normal conditions of storage and use, hazardous decomposition products should not be produced.

Toxicological information

| Acute toxicity

Component	LD ₅₀ (oral)	LD ₅₀ (dermal)	LC ₅₀ (inhalation,4h)
Zinc oxide	7950mg/kg(Mouse)	No information available	No information available

| Carcinogenicity

Component	List of carcinogens by the IARC Monographs	Report on Carcinogens by NTP
Aluminium	Not Listed	Not Listed
Zinc oxide	Not Listed	Not Listed
Liquid Polymer	Not Listed	Not Listed

| Others

High Performance Thermal Paste	
Skin corrosion/irritation	Based on available data, the classification criteria are not met
Serious eye damage/irritation	Based on available data, the classification criteria are not met
Skin sensitization	Based on available data, the classification criteria are not met
Respiratory sensitization	Based on available data, the classification criteria are not met
Reproductive toxicity	Based on available data, the classification criteria are not met
STOT-single exposure	Based on available data, the classification criteria are not met
STOT-repeated exposure	Based on available data, the classification criteria are not met
Aspiration hazard	Based on available data, the classification criteria are not met
Germ cell mutagenicity	Based on available data, the classification criteria are not met

Ecological information

| Acute aquatic toxicity

Component	Fish	Crustaceans	Algae
Aluminium	LC ₅₀ 1.55mg/L (96h)(Fish)	No information available	No information available
Zinc oxide	LC ₅₀ 1120mg/L (96h)(Fish)	No information available	No information available

| Chronic aquatic toxicity

Chronic aquatic toxicity	No information available
--------------------------	--------------------------

| Persistence and degradability

Persistence and degradability	No information available
-------------------------------	--------------------------

| Bioaccumulative potential

Component	Bioaccumulative potential	Comments
Zinc oxide	Low	BCF=217

| Mobility in soil

Mobility in soil	No information available
------------------	--------------------------

| Results of PBT and vPvB assessment

Component	Results of PBT and vPvB assessment [according to (EC) No 1907/2006]
Aluminium	Not applicable
Zinc oxide	Not applicable
Liquid Polymer	No information available

Disposal considerations

| Disposal considerations

Waste chemicals	Before disposal should refer to the relevant national and local laws and regulation. Recommend the use of incineration disposal.
Contaminated packaging	Containers may still present chemical hazard when empty. Keep away from hot and ignition source of fire. Return to supplier for recycling if possible.
Disposal recommendations	Refer to section waste chemicals and contaminated packaging.

Transport information

| Label

Transporting Label	
--------------------	---

| IMDG-CODE

UN number	3082
UN proper shipping name	ENVIRONMENTALLY HAZARDOUS SUBSTANCE, LIQUID, N.O.S.
Transport hazard class	9
Transport subsidiary hazard class	None
Packing group	III
Marine pollutant (Yes or no)	Yes

| ICAO/IATA-DGR

UN number	3082
UN proper shipping name	ENVIRONMENTALLY HAZARDOUS SUBSTANCE, LIQUID, N.O.S.
Transport hazard class	9
Transport subsidiary hazard class	None
Packing group	III

| UN-ADR

UN number	3082
UN proper shipping name	ENVIRONMENTALLY HAZARDOUS SUBSTANCE, LIQUID, N.O.S.
Transport hazard class	9
Transport subsidiary hazard class	None
Packing group	III

| Others

Methods of packing	Metal can or drum etc. Packaging as recommended by manufacturer.
Precautions for transport	Transport vehicles should be equipped with the appropriate variety and quantity of fire equipment and emergency equipment leakage during transport.
	Before

transport, should be preceded by checking whether container integrity, sealing. The transport unit must be placarded and marked in accordance with relevant transporting requirements.

Regulatory information

| International chemical inventory

Component	EC inventory	TSCA	DSL	IECSC	NZIoC	PICCS	KECI	AIICS	ENCS
Aluminium	√	√	√	√	√	√	√	√	√
Zinc oxide	√	√	√	√	√	√	√	√	√
Liquid Polymer	√	√	x	√	√	x	x	√	x

[EC inventory]	European Inventory of Existing Commercial Chemical Substances
[TSCA]	United States Toxic Substances Control Act Inventory
[DSL]	Canadian Domestic Substances List
[IECSC]	China Inventory of Existing Chemical Substances
[NZIoC]	New Zealand Inventory of Chemicals
[PICCS]	Philippines Inventory of Chemicals and Chemical Substances
[KECI]	Korea Existing Chemicals Inventory
[AIICS]	Australian. Inventory of Industrial Chemical (AIICS)
[ENCS]	Japan Inventory of Existing & New Chemical Substances

| Chinese chemical inventory

Component	A	B	C	D	E	F	G	H	I	J	K	L	M	N	O
Aluminium	√	x	x	x	x	x	x	x	x	x	√	x	x	x	x
Zinc oxide	x	x	x	x	x	x	x	x	x	x	x	x	x	x	x
Liquid Polymer	x	x	x	x	x	x	x	x	x	x	x	x	x	x	x

- [A]** Catalog of Hazardous Chemicals(2015 Edition), Notice 5th 2015, the former China State Administration of Work Safety together with the Ministry of Industry and Information Technology, etc.
- [B]** List of Toxic Chemicals Restricted in China, Notice 60th 2019, the Ministry of Ecology and Environment, Ministry of Commerce, General Administration of Customs.
- [C]** List of Ozone Depletion Chemicals Controlled to be Imported/Exported in China (2021) , Decree No. 50 of Ministry of Ecology and environment of PRC in 2021.
- [D]** Catalog of Hazardous Chemicals for Priority Management (First and Second batches) , Notice 95th, 2011, Notice 12th 2013, China State Administration of Work Safety.
- [E]** Catalog of Hazardous Chemicals for Environmental Management, Notice 33th 2014, The former Ministry of Environmental Protection.
- [F]** List of Various Monitoring Chemicals, 52th 2020, the Ministry of Industry and Information Technology.
- [G]** List of Priority Controlled Chemicals (the First batch), 83th 2017, the former Ministry of Environmental Protection, Ministry of Industry and Information Technology, the former National Health And Family Planning Commission.
- [H]** Catalog of Specially Controlled Hazardous Chemicals (First Edition), 1st2020, the Ministry of Emergency Management, Ministry of Industry and Information Technology, Ministry of Public Security, Ministry of Transport.
- [I]** List of Toxic and Harmful Water Pollutants (First batch), 28th 2019, the Ministry of Ecology and Environment, National Health Commission.
- [J]** Catalog of Highly Toxic Chemicals, Notice 142th 2003, the former Ministry of Health of P.R.China.
- [K]** Dangerous Chemicals Directory Used to Manufacture Exploder (2017 Edition), Notice 11th May. 2017, Ministry of Public Security of P.R.China.

- [L]** Catalog of Stupefacient and Psychotropic Substances, China Food and Drug Administration Notice No. 230 in 2013, No. 39 in 2020, No. 43 in 2023 and the Ministry of Public Security Notice No. 27 [2015].
- [M]** Decree No. 445 of the State Council in 2005 and its amendment announcement.
- [N]** Catalog of Import and Export Management of Precursor Chemicals, 7th 2006, the Ministry of Commerce.
- [O]** International Verification of Precursor Chemicals Management Catalog, 8th 2006, the Ministry of Commerce, Ministry of Public Security.

Note:

- “√” Indicates that the substance included in the regulations.
- “x” No data or not included in the regulations.

Other information

Information on revision

Creation Date	2023/08/14
Revision Date	2023/08/14
Reason for revision	-

Reference

- [1] IPCS: The International Chemical Safety Cards (ICSC), website: <http://www.ilo.org/dyn/icsc/showcard.home>.
- [2] IARC, website: <http://www.iarc.fr/>.
- [3] OECD: The Global Portal to Information on Chemical Substances, website: <https://www.echemportal.org/echemportal/substancesearch/index.action>.
- [4] CAMEO Chemicals, website: <http://cameochemicals.noaa.gov/search/simple>.
- [5] NLM: ChemIDplus, website: <http://chem.sis.nlm.nih.gov/chemidplus/chemidlite.jsp>.
- [6] EPA: Integrated Risk Information System, website: <http://cfpub.epa.gov/iris/>.
- [7] U.S. Department of Transportation: ERG, website: <http://www.phmsa.dot.gov/hazmat/library/erg>.
- [8] Germany GESTIS-database on hazard substance, website: <http://gestis-en.itrust.de/>.

Abbreviations and acronyms

CAS	Chemical Abstracts Service	UN	The United Nations
PC-STEL	Short term exposure limit	OECD	Organization for Economic Co-operation and Development
PC-TWA	Time Weighted Average	IMDG-CODE	International Maritime Dangerous Goods CODE
MAC	Maximum Allowable Concentration	IARC	International Agency for Research on Cancer
DNEL	Derived No Effect Level	ICAO	International Civil Aviation Organization
PNEC	Predicted No Effect Concentration	IATA	International Air Transportation Association
NOEC	No Observed Effect Concentration	ACGIH	American Conference of Governmental Industrial Hygienists
LC ₅₀	Lethal Concentration 50%	NFPA	National Fire Protection Association
LD ₅₀	Lethal Dose 50%	NTP	National Toxicology Program
EC ₅₀	Effective Concentration 50%	PBT	Persistent, Bioaccumulative, Toxic
EC _x	Effective Concentration X%	vPvB	very Persistent, very Bioaccumulative
P _{ow}	Partition coefficient Octanol: Water	CMR	Carcinogens, mutagens or substances toxic to reproduction
BCF	Bioconcentration factor	RPE	Respiratory Protective Equipment
ED	Endocrine disruptor		

Disclaimer

This Safety Data Sheet (SDS) was prepared according to GB/T17519-2013 and GB/T16483-2008. The data included was derived from international authoritative database and provided by the enterprise. Other information was based on the present state of our knowledge. We try to ensure the correctness of all information. However, due to the diversity of information sources and the limitations of our knowledge, this document is only for user's reference. Users should make their independent judgment of suitability of this information for their particular