

# EK-Quantum Vector3 TUF RTX 5090

GPU WATER BLOCK

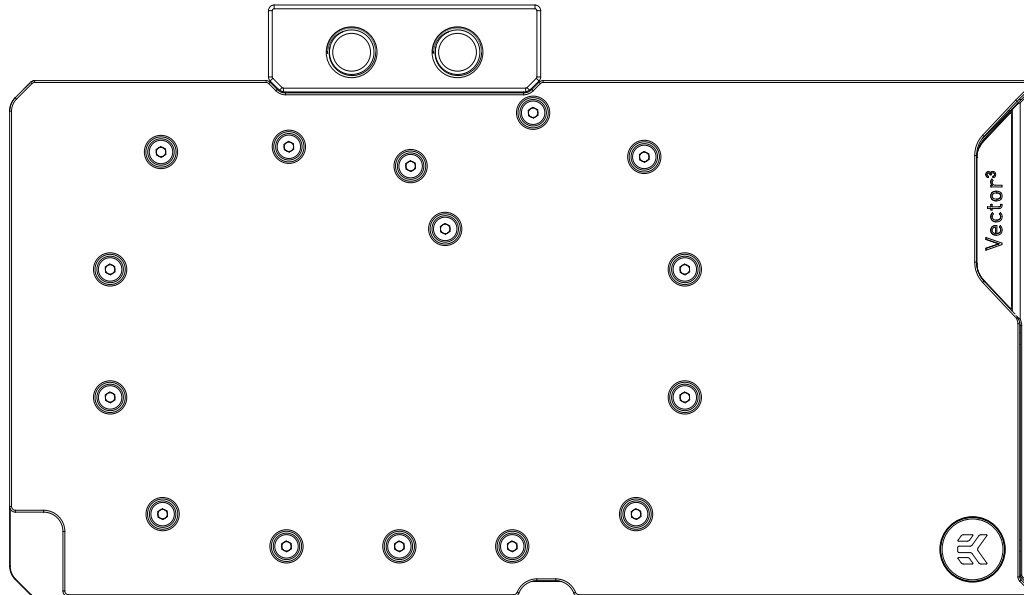

This product is intended for installation only by expert users. Please consult with a qualified technician for installation. Improper installation may result in damage to your equipment. EK Water Blocks assumes no liability whatsoever, expressed or implied, for the use of these products, nor their installation. The following instructions are subject to change without notice. Please visit our website at [www.ekwb.com](http://www.ekwb.com) for updates. Before installation of this product, please read important notice, disclosure, and warranty conditions that are printed on the back of the box.

Before you start using this product, please follow these basic guidelines:

**Please carefully read the manual before beginning the installation process.**

**The EK Fittings require only a small amount of force to screw them firmly in place since the liquid seal is ensured by the rubber O-ring gaskets.**

**The use of corrosion inhibiting coolants is always recommended for liquid cooling systems, and mandatory for nickel plated water blocks.**







**Do not use pure distilled water! For best results EK recommends the use of EK-Cryo Fuel coolants.**

**Make sure to thoroughly bleed air out of your water block, or you will not reach optimal performance.**

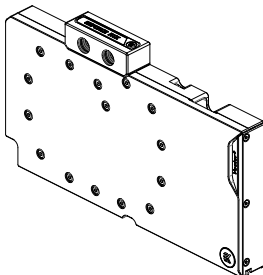
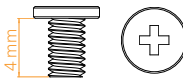
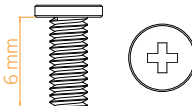
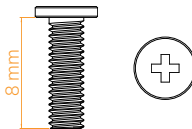
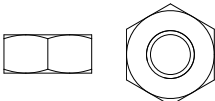
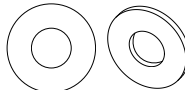
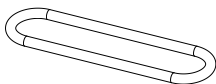
# TABLE OF CONTENTS

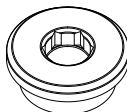
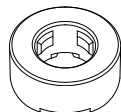
<b>BOX CONTENTS .....</b>	<b>4</b>
<b>WATER BLOCK DIMENSIONS .....</b>	<b>5</b>
<b>TECHNICAL SPECIFICATIONS AND WATER BLOCK PARTS .....</b>	<b>6</b>
<b>NICKEL PLEXI.....</b>	<b>6</b>
<b>PREPARING THE GRAPHIC CARD .....</b>	<b>7</b>
<b>PREPARING THE WATER BLOCK FOR INSTALLATION .....</b>	<b>8</b>
<b>CUTTING AND PLACING THERMAL PADS - WATER BLOCK.....</b>	<b>9</b>
<b>APPLYING THERMAL COMPOUND .....</b>	<b>11</b>
<b>ATTACHING THE WATER BLOCK .....</b>	<b>11</b>
<b>CUTTING AND PLACING THERMAL PADS - PCB PWR CONNECTOR .....</b>	<b>13</b>
<b>ATTACHING THE BACKPLATE.....</b>	<b>14</b>
<b>INSERTING THE GRAPHICS CARD INTO THE CHASSIS.....</b>	<b>14</b>
<b>CONNECTING THE D-RGB LED STRIP .....</b>	<b>15</b>
<b>TESTING THE LOOP.....</b>	<b>16</b>
<b>WARRANTY .....</b>	<b>16</b>
<b>SUPPORT AND SERVICE.....</b>	<b>17</b>

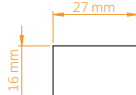
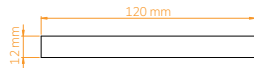
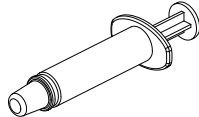
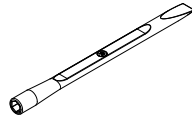
# BOX CONTENTS

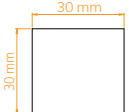
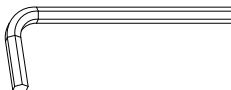
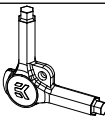
 <p>EK-Quantum Vector3 TUF RTX 5090</p>		 <p>M2.5x4 AX1 Screw (6 pcs)</p>	 <p>M2.5x6 AX1 Screw (6 pcs)</p>	 <p>M2.5x8 AX1 Screw (2 pc)</p>
		 <p>Nut M2.5 (1 pcs)</p>	 <p>Polyamid Washer M2.5 0.5mm (6 pcs)</p>	 <p>Terminal OR 14x1 mm (2 pcs)</p>
 <p>Thermal Pad - VRAM 68x16x2 (2 pcs)</p>	 <p>Thermal Pad - VRAM 55x16x2 (1 pc)</p>	 <p>Quantum Plug (2 pcs)</p>	 <p>Standoff Ø4.5/2.5 (2 pc)</p>	 <p>Allen Key 2 mm (1 pc)</p>
 <p>Thermal Pad - VRAM 27x16x2 (1 pc)</p>	 <p>Thermal Pad -Inductor 120x12x1 (2,5 pcs)</p>	 <p>Thermal Grease (1 pc)</p>	 <p>EK-Plug Out Spludger Tool (1 pc)</p>	
 <p>Thermal Pad -VRM 120x6x2 (2,5 pcs)</p>	 <p>Thermal Pad BP Chip 30x30x1 (1,5 pcs), 2nd rev: 30x15x3 (1pc)</p>	 <p>Allen Key 2.5 mm (1 pc)</p>	 <p>EK-Loop Multi Allen Key (1 pc)</p>	

EAN: 107997

# WATER BLOCK DIMENSIONS

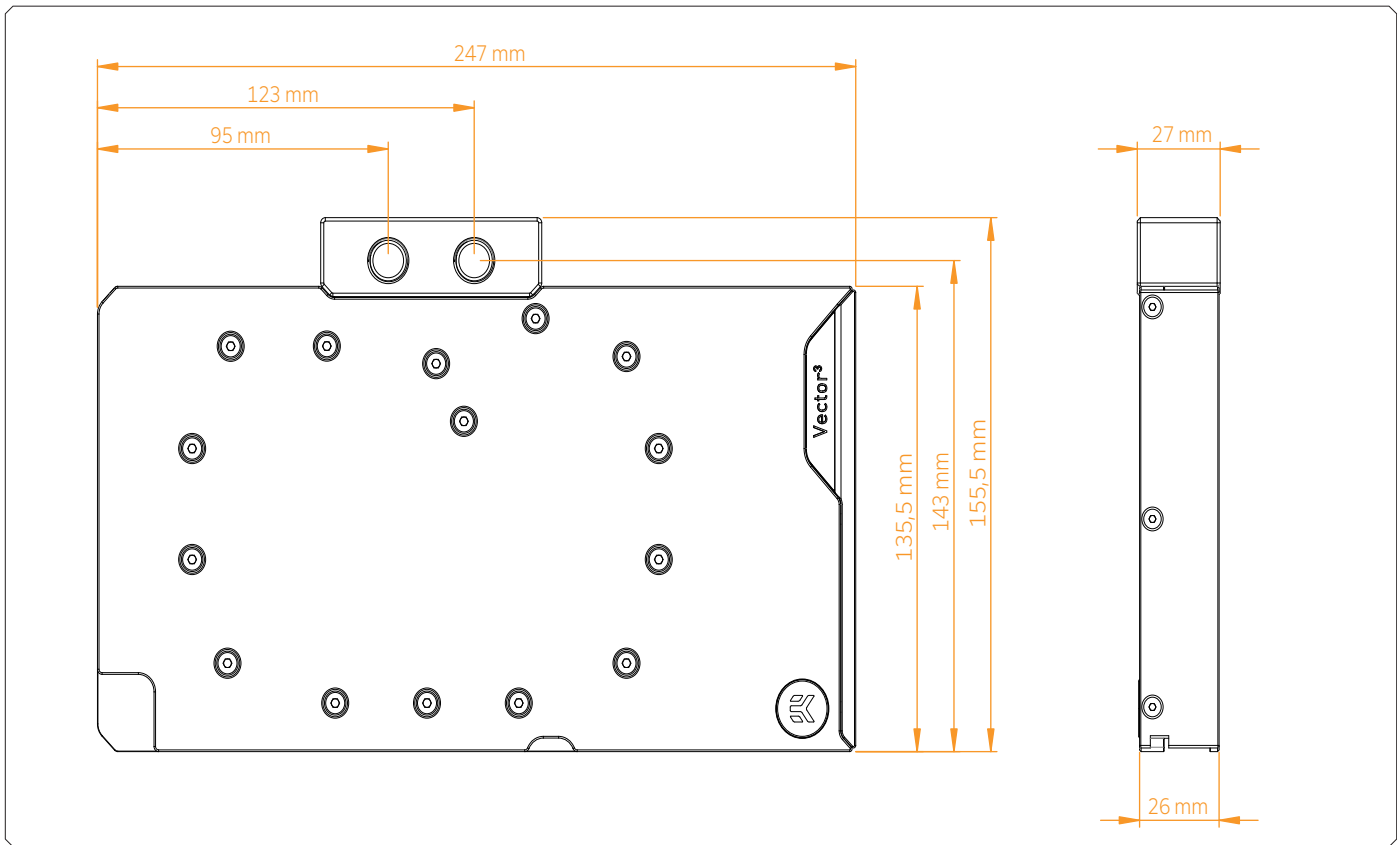

## TECHNICAL SPECIFICATIONS AND WATER BLOCK PARTS

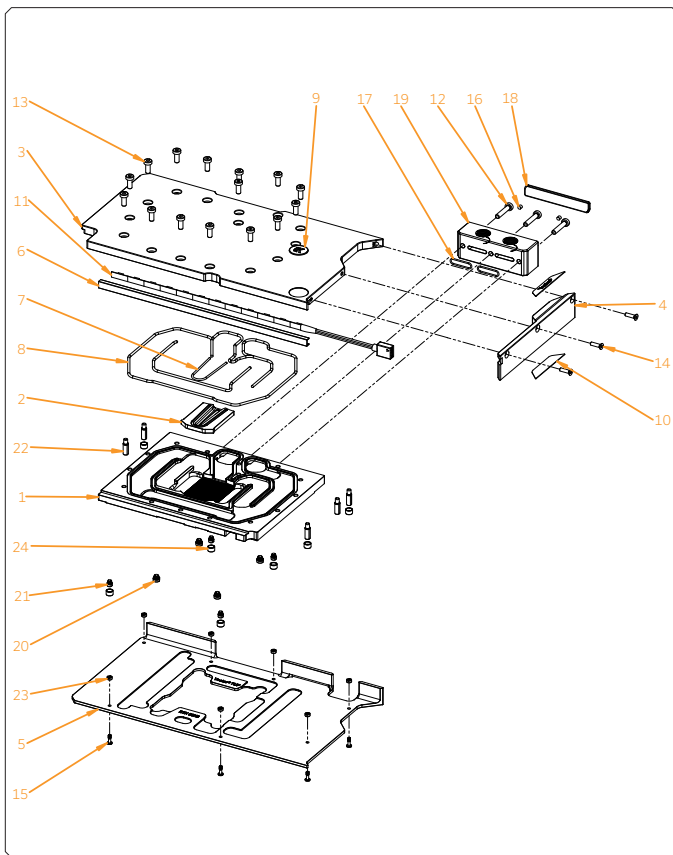

### NICKEL PLEXI

#### Technical Specification:

Dimensions (L x H x W): 247 x 155,5 x 27 mm

D-RGB cable length: 500 mm

D-RGB LED count: 12

D-RGB connector standard 3-pin (+5V, Data, Blocked, Ground)

Pos.	EAN	Name	Qty.
1	107962	Coldplate (Ni)	1
2	107968	Plexi Insert	1
3	107944	Top Plate (Plexi)	1
4	107929	Standout (Acetal)	1
5	107982	Backplate (Bl. Elox)	1
6	106957	LED Cover (Nat. Elox)	1
7	107994	OR - Jet Insert - Vector3	1
8	107951	OR - Vector3 Astral RTX 5090	1
9	100663	EK Badge	1
10	106701	Mylar sticker	2
11	101556	LED D-RGB strip	1
12	8311	Screw M4x20 DIN7984	3
13	9024	Screw DIN 7984 - M4 x 10	15
14	9041	Screw M3x11 DIN7991	3
15	104187	Screw M2,5x8 AX1n Black 12.8	7
16	104216	Disc magnet 3x3	2
17	104106	Terminal OR - Vector2 14x1 mm	2
18	103942	Terminal Badge	1
19	105988	FC Terminal (Acetal)	1
20	108005	Standoff M4-M2 x 3mm Vector3	4
21	103987	Standoff M3,5-M2,5 x 3	4
22	103986	Standoff M3,5-M2,5 x 11,3mm	5
23	104188	Standoff fi 4,5/2,5	7
24	/	Spacer - PCB Gap Cap	7

## PREPARING THE GRAPHIC CARD

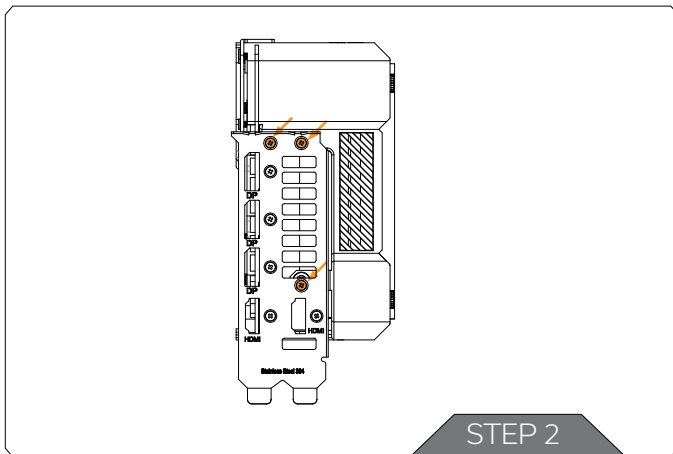
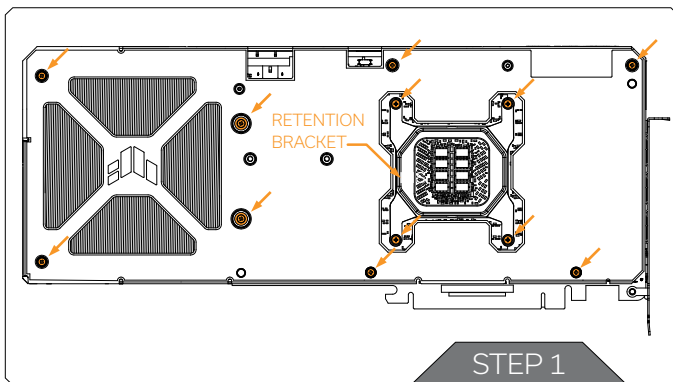

### REMOVING THE STOCK COOLER

#### ASUS TUF GEFORCE RTX 5090



**Important!** Before starting, make sure to have a clean, flat surface to work on. It is recommended to put foam or soft material to lay the graphics card on.

#### STEP 1

First, remove twelve (12) screws from the backside of the Stock cooler (using Phillips head screwdriver) and remove the Retention bracket.

#### STEP 2

Unscrew three (3) screws from the I/O Bracket (using Phillips head screwdriver).

Disconnect the connectors and gently lift the stock cooler off the GPU PCB.

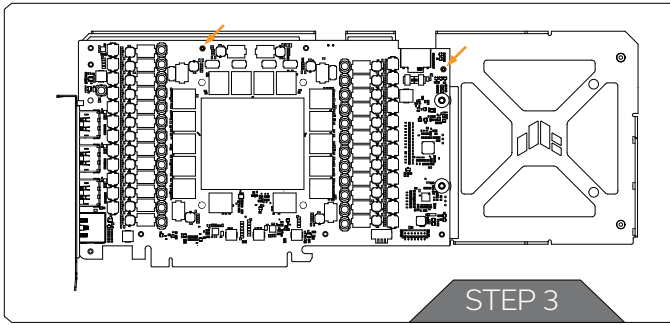

### STEP 3

Additional two (2) screws must be removed (using Phillips head screwdriver). Detach the GPU PCB from the backplate.

Remove the old thermal paste from the GPU die using a non-abrasive cloth or a Q-tip.

## PREPARING THE WATER BLOCK FOR INSTALLATION

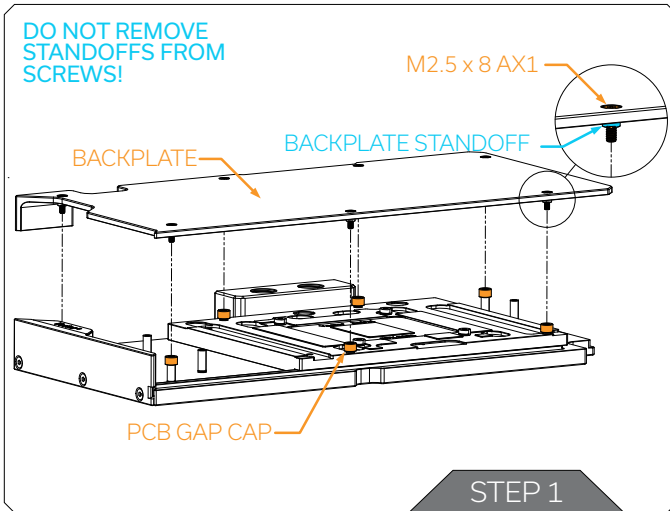

Unscrew seven (7) Screws AX1 M2.5 x 8 mm. Remove the backplate together with the Screws and backplate standoffs Standoffs must stay on Screws AX1 M2.5 x 8 mm. **Remove the orange PCB gap caps.**



Do not remove standoffs from screws! In case the standoff detaches from the screw, replace it with a spare one. When replacing the standoff make sure that you screw it on the AX1 M2.5 x 8 screws. Do not push the standoff onto the screw AX1 M2.5 x 8 mm.

For this step, you will need:

Phillips Head Screwdriver

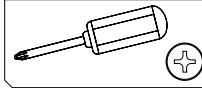

# CUTTING AND PLACING THERMAL PADS - WATER BLOCK

## STEP 1

The GPU water block comes with pre-cut thermal pads, but some of them need to be additionally cut into smaller pieces.



Remove the protective foil from both sides of the thermal pad before installation.

Replacement thermal pads (EAN 107997):

- Thermal Pad - VRAM - 68x16x2 mm - 2 pcs
- Thermal Pad - VRAM - 55x16x2 mm - 1 pc
- Thermal Pad - VRAM - 27x16x2 mm - 1pc
- Thermal Pad - Inductor - 120x12x1 mm - 2,5 pcs
- Thermal Pad - VRM - 120x6x2 mm - 2,5 pcs

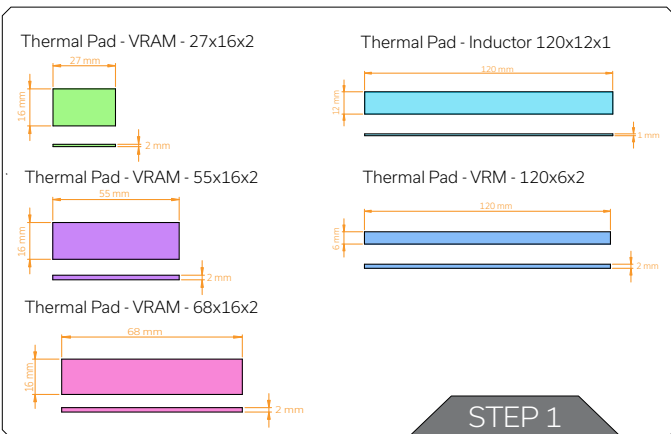

## STEP 2

Use two (2) Thermal Pad - VRAM - 68x16x2 mm

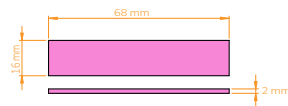

Use one (1) Thermal Pad - VRAM - 55x16x2 mm

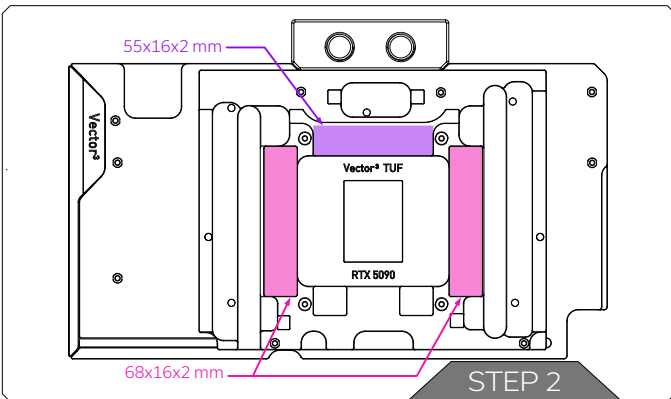
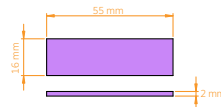

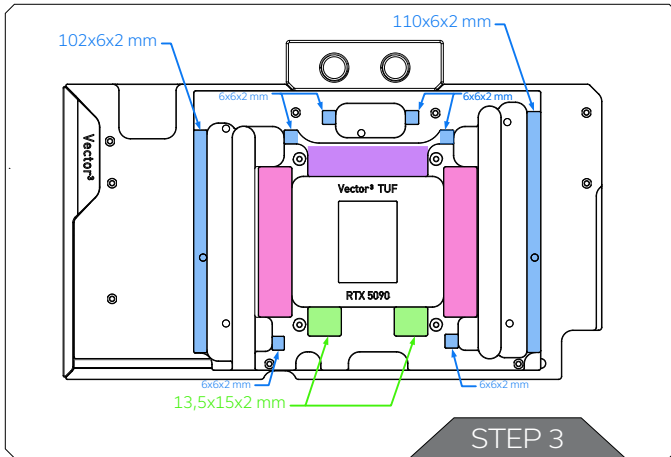

### STEP 3

Use one (1) Thermal Pad - VRAM - 27x16x2 mm

Cut it in half (13,5x16 mm)

Thermal Pad - VRAM - 27x16x2

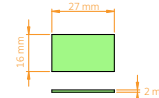

Use one (2) Thermal Pad - VRM - 120x6x2 mm

Cut one (1) to a length of 96 mm.

Cut one (1) to a length of 104 mm.

Cut the remaining Thermal Pad - VRM - 120x6x2 mm to a 6mm length (6 pcs).

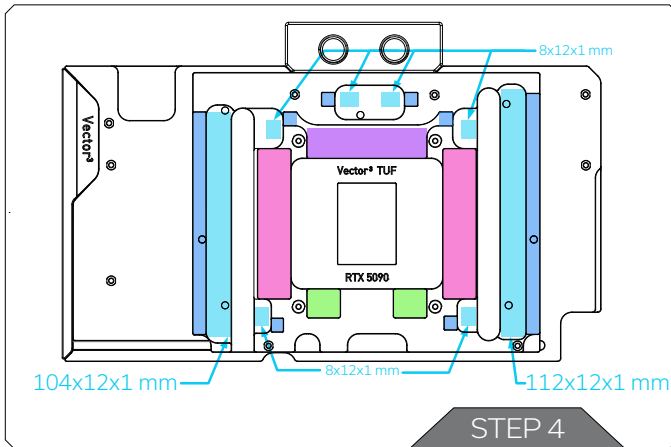
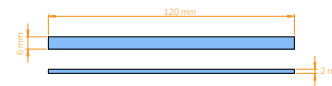

### STEP 4

Use two (2) Thermal Pad - Inductor - 120x12x1 mm

Cut one (1) to a length of 104 mm.

Cut one (1) to a length of 112 mm.

Cut the remaining Thermal Pad - VRM - 120x12x1 mm to a 8mm length (6 pcs).

Thermal Pad - Inductor 120x12x1



## APPLYING THERMAL COMPOUND

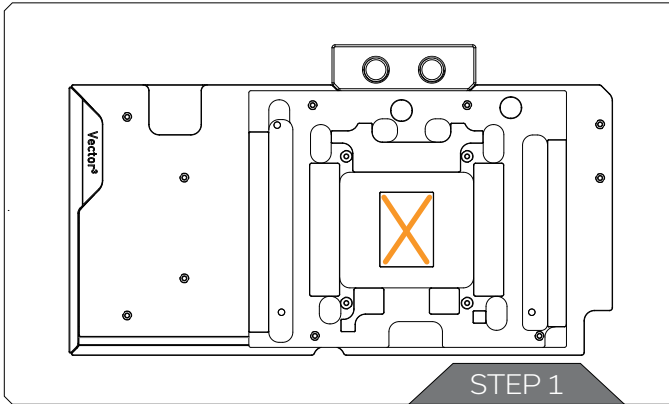

### STEP 1

Apply the enclosed thermal grease (thermal compound) on the GPU die – as shown in the image. The layer of the thermal compound must be thin and even over the entire die surface.



The excessive or uneven application of thermal grease may lead to poor performance!

For this step, you will need:

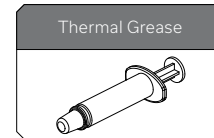

## ATTACHING THE WATER BLOCK

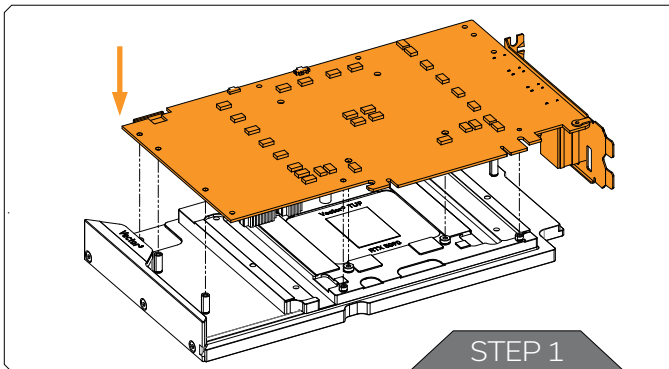

### STEP 1

Carefully position the PCB on the water block. During this process, make sure you have aligned the mounting holes of the PCB with the holes of the water block.



Pay attention not to use too much force when pressing the PCB down to the block since chip dies are prone to cracking.



Before attaching the PCB to the Water Block, make sure all the Thermal Pads are placed correctly!

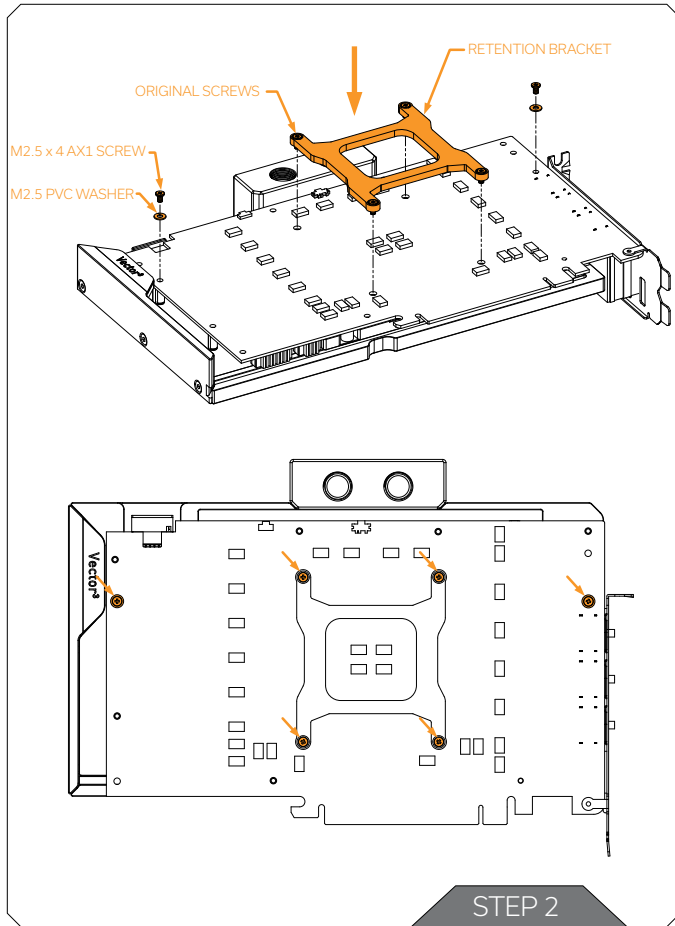

## STEP 2

To secure the PCB to the water block, use two (2) PVC washers and two (2) M2.5 x 4 AX1 screws.

Carefully align the retention bracket onto the water block and tighten four (4) original screws in a criss-cross pattern.

It is recommended to partially screw in all the screws first, then tighten them evenly using a Phillips head screwdriver.

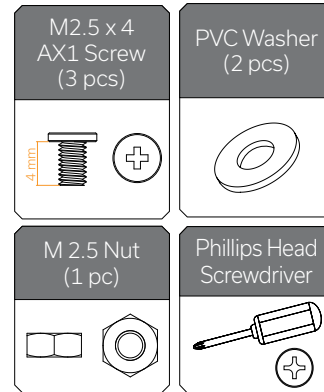

Screws must be present in the places marked on the picture.

## CUTTING AND PLACING THERMAL PADS - PCB PWR CONNECTOR

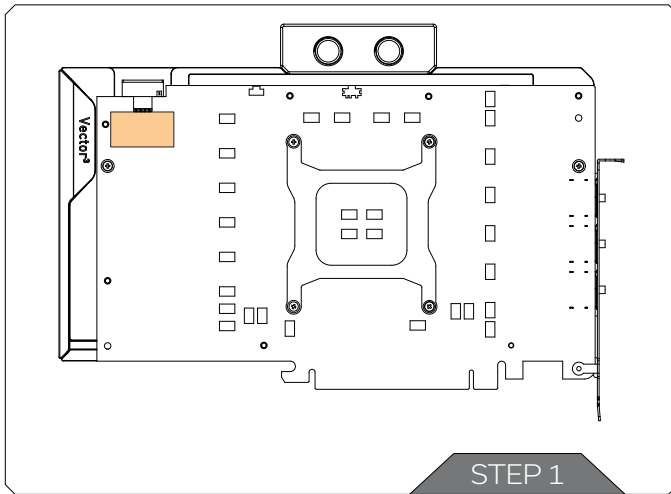

### STEP 1

Use one (1) Thermal pad BP Chip 30x30x1 mm and cut in half so you get two (2) pcs of 30x15x1 mm. One (1) pc of 30x30x1 mm is already precut in the set.

Stack all three (3) pcs and place them on the PCB.

Thermal Pad - BP Chip - 30x30x1

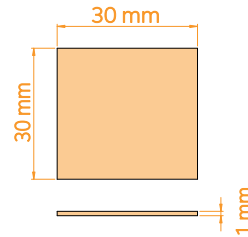

2<sup>nd</sup> revision with a precut thermal pad: Use one (1) Thermal pad BP Chip 30x15x3 mm and place it on the PCB.

Thermal Pad - BP Chip - 30x15x3

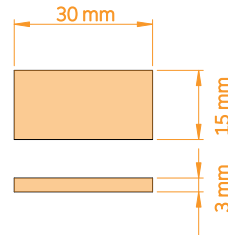

## ATTACHING THE BACKPLATE

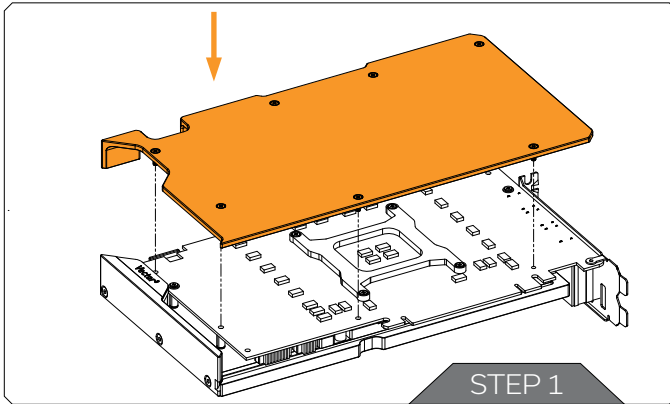

### STEP 1

Position the Backplate (including screws and standoffs) onto the GPU PCB. Make sure all the holes are aligned. Tighten the screws evenly.

**Do not use excessive force!**

For this step, you will need:

Phillips Head  
Screwdriver

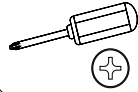

## INSERTING THE GRAPHICS CARD INTO THE CHASSIS

Carefully lift your graphics card with the installed water block and insert it into your PC's motherboard PCI Express expansion slot. Please keep in mind that your graphics card is heavier than before it was equipped with the water block.



You need to be very careful when handling the graphics card. Avoid all unnecessary manipulation of the water block assembly that might damage your card or water block.

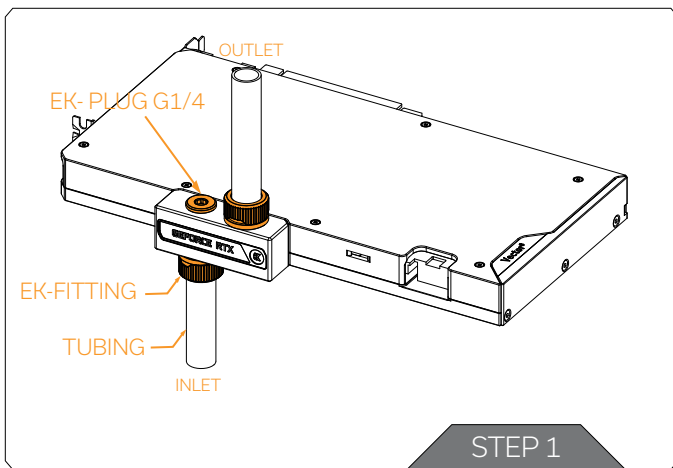

### STEP 1

Screw in two (2) G1/4 threaded male fittings. Attach the liquid cooling tubes and connect the water block to the cooling loop.



Do not forget to plug the remaining two openings using the enclosed EK-Plug G1/4 or its equivalent.

**EK recommends using EK fittings with all EK water blocks.**



**CAUTION:** When using connectors other than EK fittings, pay special attention to the length of the fittings' male G1/4" thread - 5mm is the maximum G1/4" thread length allowed!

For this step, you will need:

EK-Loop Multi Allen Key



## CONNECTING THE D-RGB LED

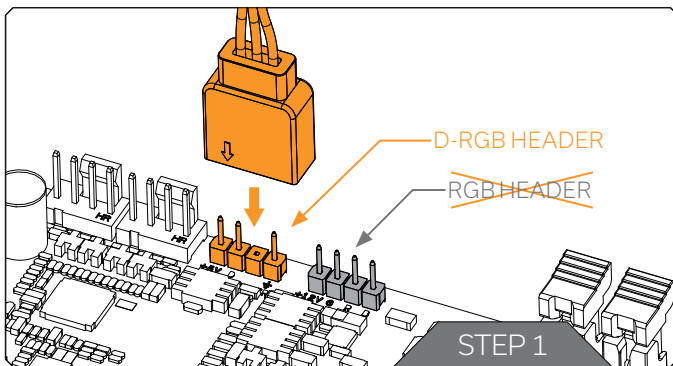

### STEP 1

Plug the 3 Pin connector from the water block's D-RGB LED light to the DRGB HEADER on the motherboard. The LED will work if the pin layout on the header is as follows: +5V, Digital, empty, Ground.



Please ensure that the arrow indicated on the connector is plugged into the +5V line as indicated on your motherboard. If you put the LED Diode to the 12V RGB HEADER you can damage the LEDs. Failure to do so will damage your motherboard or LED strip.

## TESTING THE LOOP

To make sure the installation of EK components was successful, we recommend you perform a leak test for 24 hours. When your loop is complete and filled with coolant, connect the pump to a PSU outside of your system. Do not connect power to any of the other components. Turn on the PSU and let the pump run continuously. It is normal for the coolant level to drop during this process as air collects in the distribution plate. Inspect all parts of the loop, and in the eventuality, that coolant leaks, fix the issue and repeat the testing process. Ensure that all hardware is dry before the system is powered on in order to prevent any damage.

## WARRANTY

Our products are warranted against defects of materials and quality for a period of 24 months, starting with the date of delivery to the end-user. During this period, products will be repaired or have parts replaced at our discretion, provided that 1) the product is returned to the agent from whom it was purchased; 2) the product has been purchased by the end-user and has not been used for commercial purposes; 3) the product has not been misused, handled carelessly, or used in a manner other than the way described in the instructions manual. This warranty does not confer rights other than those expressly set out above and does not cover any claims for consequential loss or damage. This warranty is offered as an extra benefit and does not affect your statutory rights as a consumer. This warranty is voided if the product comes in contact with aggressive UV additives or other improper liquids. EK water blocks are sealed with a warranty-voiding circular label, proving the water block has withstood a pressure leak test. Removing the label will void the leak-free guarantee, but not the guarantee on the product itself. Any other RMA issues can be reported to EK Customer Support at [www.ekwb.com/support](http://www.ekwb.com/support) for further analysis.

## SUPPORT AND SERVICE

In case you need assistance or wish to order spare parts or a new mounting mechanism, please contact:

**<https://www.ekwb.com/customer-support/>**

For spare parts orders, refer to the page with "TECHNICAL SPECIFICATIONS AND WATER BLOCK PARTS" where you can find the EAN number of each part you might need.

Include the EAN number with quantity in your request. Mounting Mechanism EAN can be found under "BOX CONTENTS"

Thermal pads are readily available in the EKshop

## SOCIAL MEDIA

 EKWaterBlocks

 @EKWaterBlocks

 ekwaterblocks

 EKWBofficial

 ekwaterblocks

