

EK-Quantum Convection D5 D-RGB

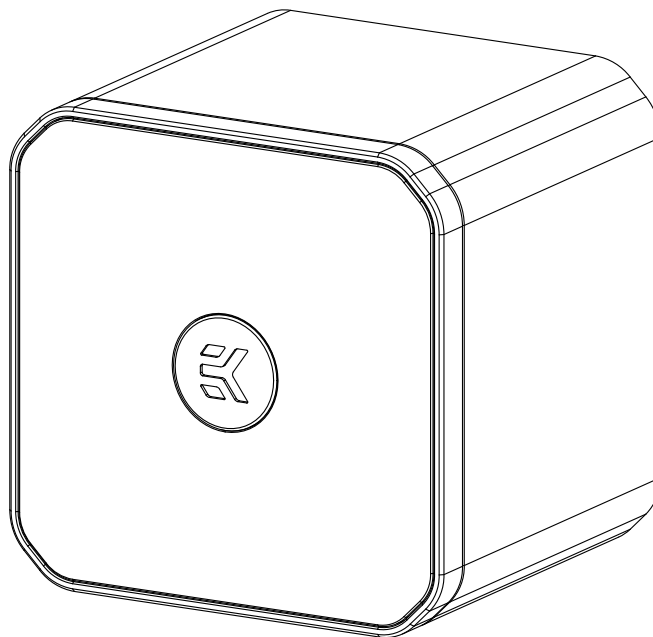

Please note the installation of the product is intended to be undertaken by an adequately trained and experienced person. You are installing the product at your own risk. If you are not properly trained or experienced or feel unsure about the installation procedure, please refrain from installing the product yourself and contact our tech support for assistance. We disclaim our liability for any damages to the product as well as incidental, consequential, or indirect damages incurred due to improper or inappropriate installation.

Before you start using this product, please follow these basic guidelines:

Carefully read the manual before beginning with the installation process.

The use of corrosion-inhibiting coolants is always recommended for liquid cooling systems and mandatory for nickel-plated water blocks!

Do not use pure distilled water!

For best results, EK recommends the use of EK-CryoFuel coolants! To reach optimal performance, make sure to thoroughly bleed the air out of your water block!

TABLE OF CONTENTS

| | |
|--|-----------|
| BOX CONTENTS | 4 |
| PRODUCT DIMENSIONS | 5 |
| TECHNICAL SPECIFICATIONS AND MAIN PARTS | 6 |
| INSTALLING THE PUMP COVER | 7 |
| CONNECTING THE D-RGB LED STRIP | 10 |
| CONNECTING THE PUMP | 10 |
| TESTING THE LOOP | 11 |
| SUPPORT AND SERVICE | 12 |
| SOCIAL MEDIA | 12 |

BOX CONTENTS

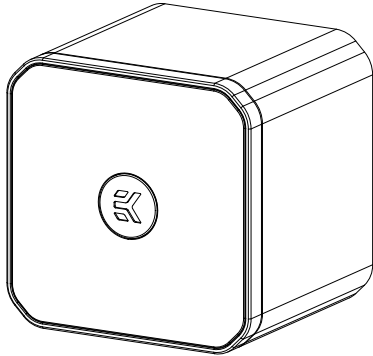

D5 Convection Cover Assembly (1 pc)

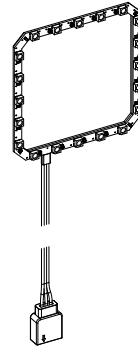

LED D-RGB Strip (1 pc)



M4 x 50 DIN7984 Screw (4 pcs)

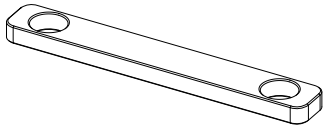

Metal cable holder (1 pc)

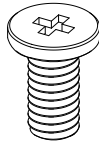

M2.5 x 5 AX1 Screw (2 pcs)

PRODUCT DIMENSIONS

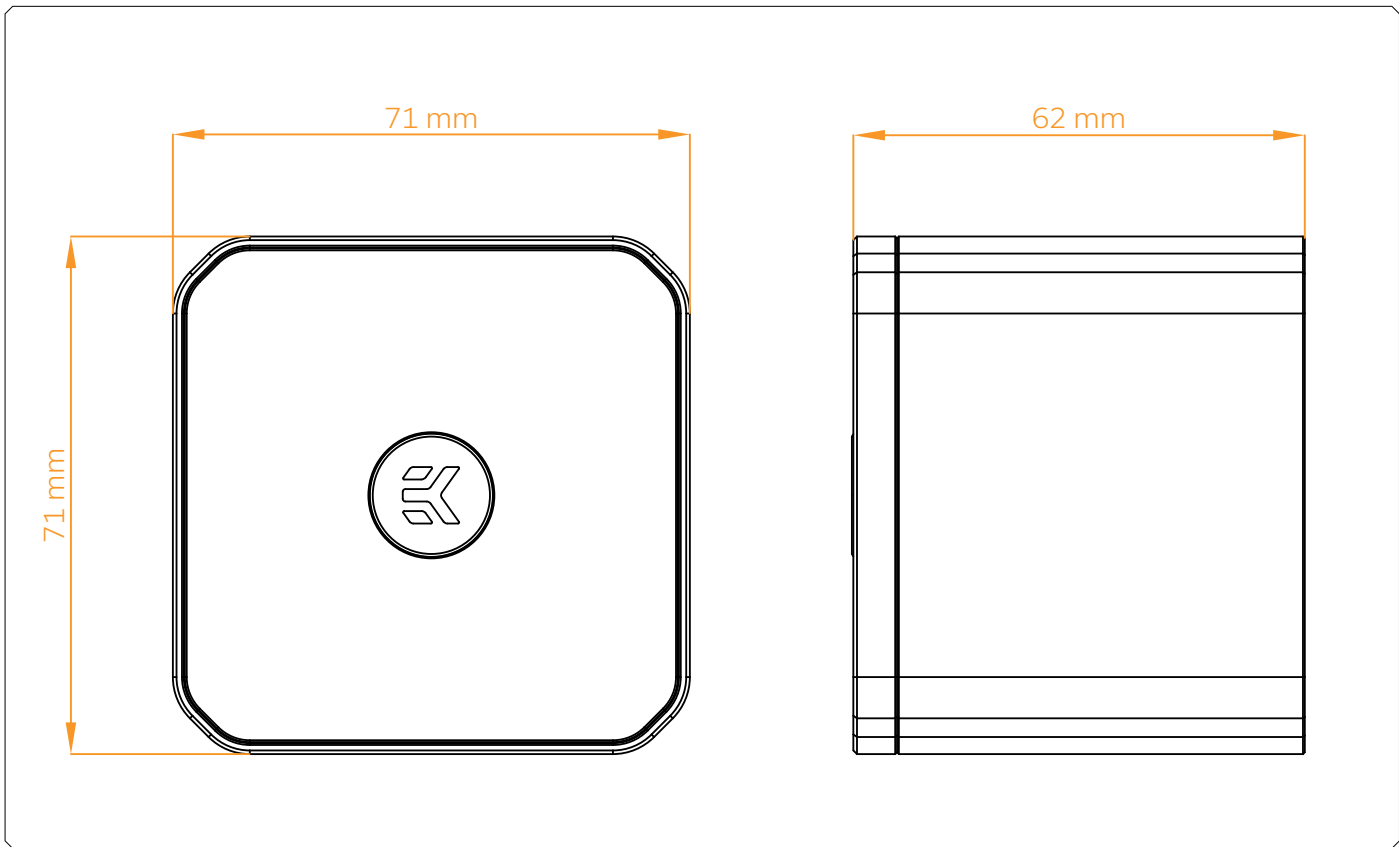

TECHNICAL SPECIFICATIONS AND MAIN PARTS

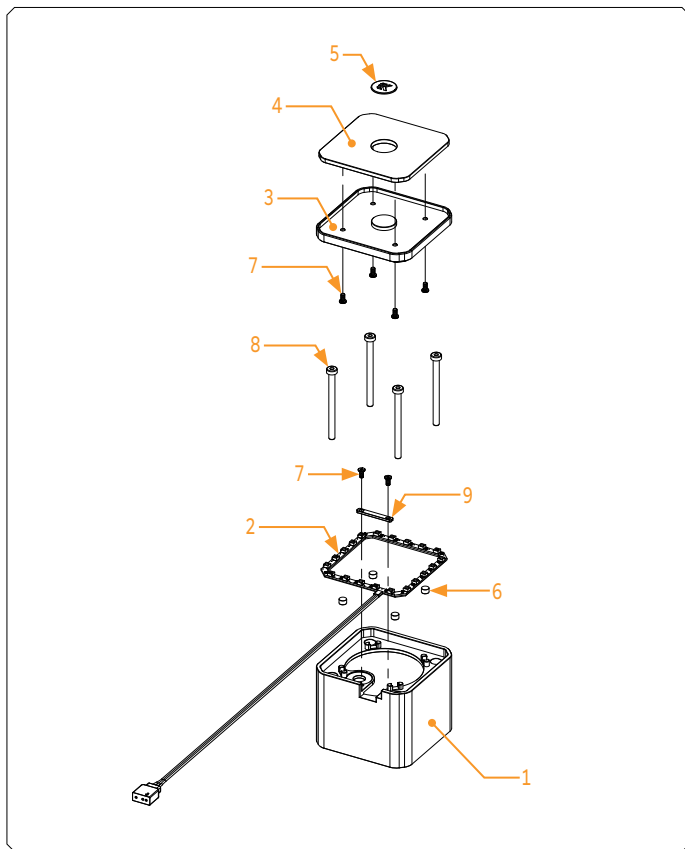

Technical Specification:

- Dimensions (L x H x W): 71 x 71 x 62 mm
- D-RGB LED count: 20
- D-RGB cable length: 50 cm
- D-RGB connector 3-pin 5V digital LED header (Pinout: +5V | Data | Blocked | Ground)

| Position | EAN | Description | Quantity |
|----------|--------|---|----------|
| 1.1 | 107465 | ALU - Convection D5 D-RGB - Base (Nickel) | 1 |
| 1.2 | 107446 | ALU - Convection D5 D-RGB - Base (Black) | 1 |
| 1.3 | 107447 | ALU - Convection D5 D-RGB - Base (Silver) | 1 |
| 2 | 100673 | LED D-RGB Strip | 1 |
| 3 | 107439 | Light Guide | 1 |
| 4.1 | 107467 | LED Cover (Nickel) | 1 |
| 4.2 | 107443 | LED Cover (Black) | 1 |
| 4.3 | 107442 | LED Cover (Silver) | 1 |
| 5 | 100663 | EK RGB Badge | 1 |
| 6 | 107468 | Disc magnet 5 x 3 | 4 |
| 7 | 9048 | Screw M2.5 x 5 AX1 | 6 |
| 8 | 107463 | Screw M4 x 50 DIN7984 | 4 |
| 9 | 107492 | Cable holder | 1 |

INSTALLING THE PUMP COVER

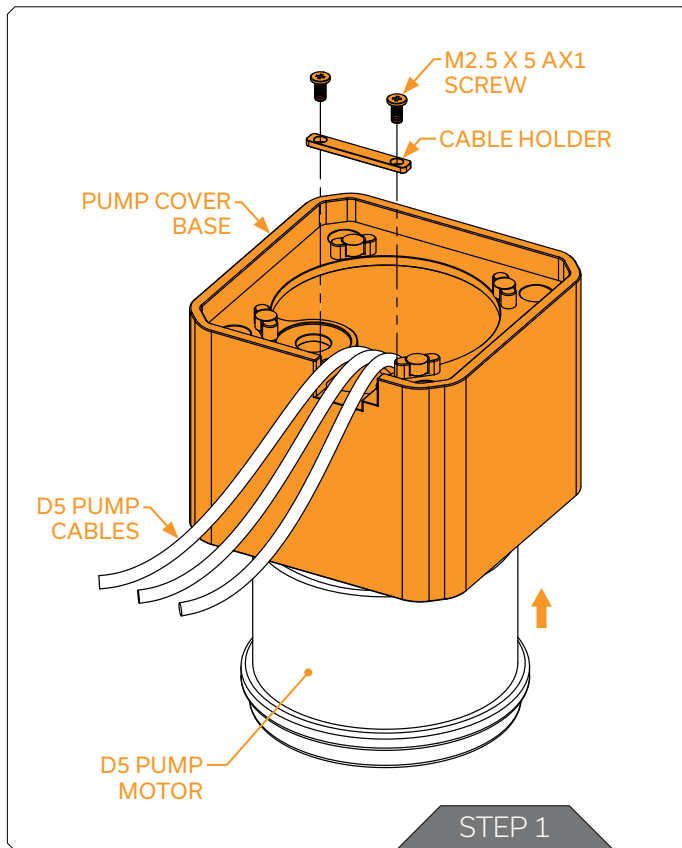

STEP 1

Insert the D5 Pump into the Pump Cover Base and position the cables in the shown place. Secure the cables with the provided metal Cable Holder and two (2) M2.5 x 5 AX1 Screws.



*The D5 Pump is not included in the package!

For this step, you will need:

D5 Pump
(1 pc)



Cable holder
(1 pc)



M2.5 X 5 AX1
Screw (2 pcs)



Pump Cover Base
(1 pc)

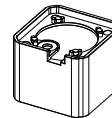

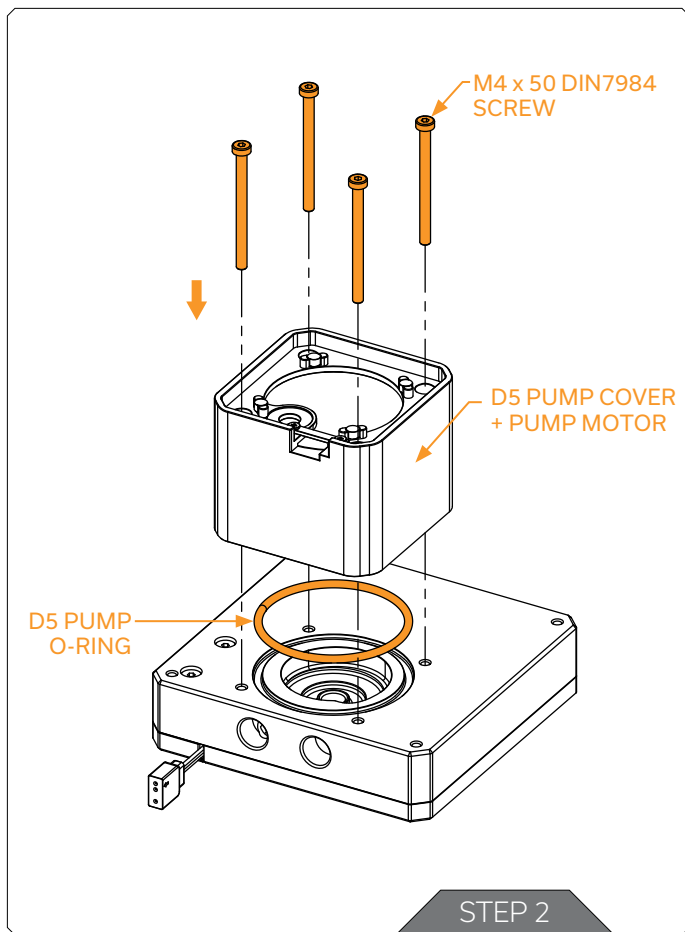

STEP 2

After securing the cables, position the D5 Pump Cover onto the desired product and secure it with four (4) M4 X 50 DIN7984 mounting screws. Make sure to not overtighten the screws! Max Torque: 0.6Nm.



Make sure to insert the D5 Pump O-ring into the sealing slot before securing the screws!

For securing the screws, EK recommends the use of **EK-Loop Torque Screwdriver - 0.6Nm:**

<https://www.ekwb.com/shop/ek-loop-torque-screwdriver-0-6nm>

For this step, you will need:

M4 x 50 DIN7984
(4 Pcs) EAN: 107463



D5 Pump O-ring
(1 pc) EAN: 5154

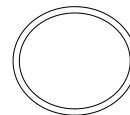

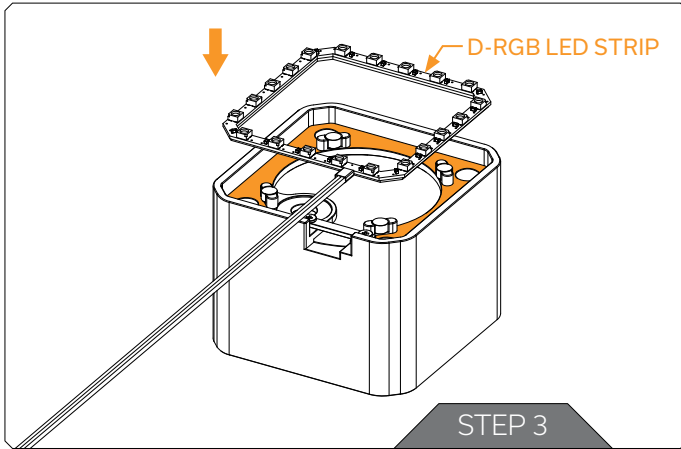

STEP 3

STEP 3

Place the D-RGB LED Strip in the shown place. The D-RGB LED strip does not need to be glued.

For this step, you will need:

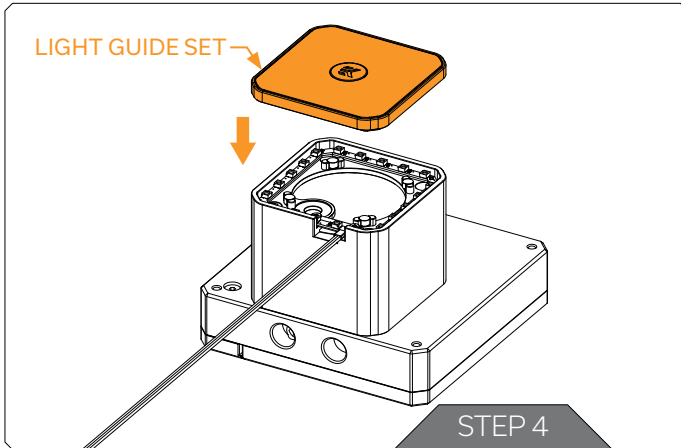
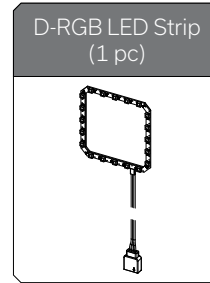

STEP 4

STEP 4

Pick up the pre-assembled Light Guide set and carefully place it over the D-RGB LED Strip. The magnets will hold down the Light Guide. The Light Guide set can be rotated.

For this step, you will need:

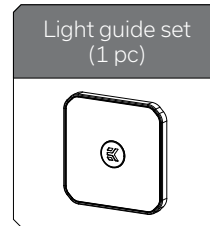

CONNECTING THE D-RGB LED STRIP

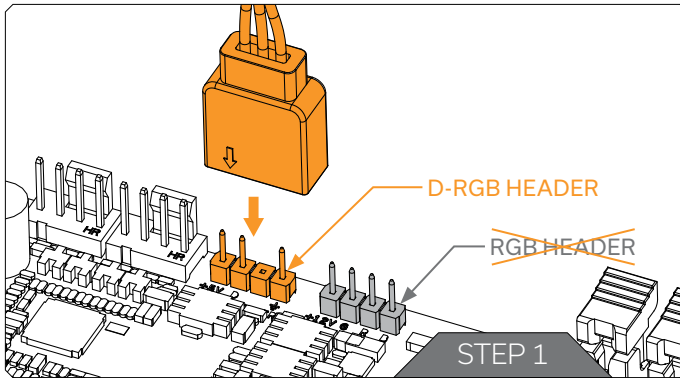

STEP 1

Plug the 3-pin connector of the Pump cover D-RGB LED light to the D-RGB HEADER on the motherboard. The LED will work if the pin layout on the header is as follows: **+5V, Digital, empty, Ground**.

CONNECTING THE PUMP

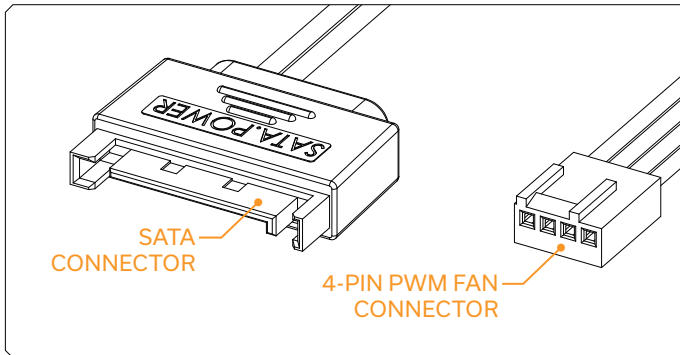

The EK-D5 PWM pump has two connectors.

- 1. SATA Connector:** It must be connected directly to your PSU at all times as it is used to power the pump.
- 2. 4-pin PWM fan:** It can be connected to your motherboard's CPU_Fan or designated water pump header. It can also be connected to a controller. This cable is used to control and report the rotational speed of the pump. If it's not connected, the pump will run at maximum speed (100% PWM).

TESTING THE LOOP

To make sure the installation of EK components was successful, we recommend you perform a leak test for 24 hours.

When your loop is complete and filled with coolant, connect the pump to a PSU outside of your system. Do not connect power to any of the other components. Turn on the PSU and let the pump run continuously. It is normal for the coolant level to drop during this process as air collects in the distribution plate.

Inspect all parts of the loop, and in the eventuality that coolant leaks, fix the issue and repeat the testing process. Ensure that all hardware is dry before the system is powered on in order to prevent any damage.

SUPPORT AND SERVICE

In case you need assistance or wish to order spare parts or a new mounting mechanism, please contact:

<https://www.ekwb.com/customer-support/>

For spare parts orders, refer to the page with "TECHNICAL SPECIFICATIONS AND PRODUCT PARTS" where you can find the EAN number of each part you might need.

Include the EAN number with quantity in your request. Mounting Mechanism EAN can be found under "BOX CONTENTS"

Thermal pads are readily available in the EK shop

SOCIAL MEDIA

 EKWaterBlocks

 @EKWaterBlocks

 ekwaterblocks

 EKWBofficial

 ekwaterblocks

