

EK-Quantum

Velocity² Direct Die D-RGB - AMD Ryzen Signature Edition

Velocity² Direct Die D-RGB - AMD Ryzen Edition

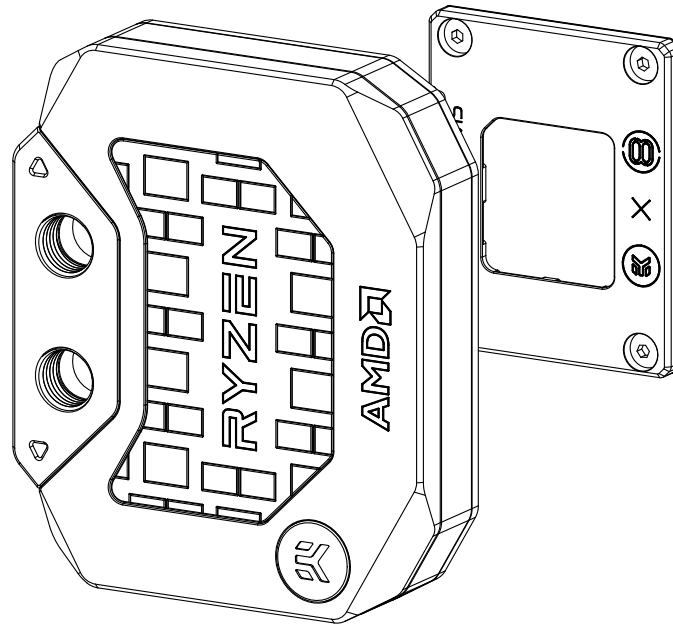

Please note the installation of the product is intended to be undertaken by an adequately trained and experienced professional. If you are not properly trained or experienced or feel unsure about the installation procedure, please refrain from installing the product yourself and contact our tech support for assistance. You are installing the product at your own risk.

Before you start using this product, please follow these basic guidelines:

Please carefully read the manual before beginning the installation process.

The EK Fittings require only a small amount of force to screw them firmly in place since the liquid seal is ensured by the rubber O-ring gaskets.

The use of corrosion inhibiting coolants is always recommended for liquid cooling systems, and mandatory for nickel plated water blocks.

Do not use pure distilled water! For best results EK recommends the use of EK-Cryo Fuel coolants.

Make sure to thoroughly bleed air out of your water block, or you will not reach optimal performance.

Delidding entails a very risky modification of the CPU and may, even if properly performed, result in damage to the processing unit.

Delidding a CPU voids AMD warranty

We disclaim all our liability for any damages to the product or the CPU as well as incidental, consequential, or indirect damages incurred during or as a consequence of delidding.

TABLE OF CONTENTS

GENERAL INFORMATION ON WATER BLOCK COMPATIBILITY	4
BOX CONTENTS AMD Ryzen Signature Edition	4
BOX CONTENTS AMD Ryzen Edition	5
WATER BLOCK DIMENSIONS	6
TEHNICAL SPECIFICATIONS AND WATER BLOCK PARTS	7
DELIDDING THE CPU	8
PREPARING THE CPU	8
PREPARING THE MOTHERBOARD	9
INSTALLING THE DIE GUARD AND APPLYING THE PASTE	10
INSTALLING THE CPU WATER BLOCK	11
CONNECTING THE D-RGB LED STRIP	13
SUPPORT AND SERVICE	14
SOCIAL MEDIA	14







GENERAL INFORMATION ON WATER BLOCK COMPATIBILITY

This CPU liquid cooling unit is pre-assembled for use with modern AMD desktop socket-type motherboards. By default (out of the box) this water block supports the following CPU sockets:

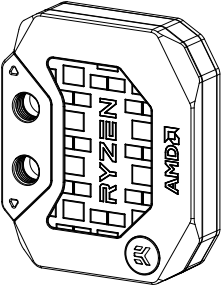
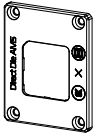
- AMD® socket AM5

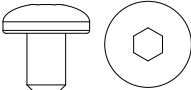
BOX CONTENTS AMD Ryzen Signature Edition

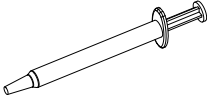
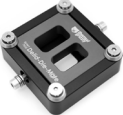
Mounting Mechanism EAN: 107603

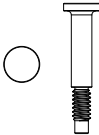
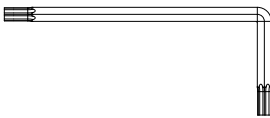
	 <p>Die Guard (1 pc)</p>	 <p>Allen Key 2 mm (1 pc)</p>	 <p>Allen Key 2.5 mm (1 pc)</p>
<p>EK-Quantum Velocity² Direct Die D-RGB - AMD Ryzen Signature Edition</p>	 <p>Screw UNC 6/32x5 (4 pcs)</p>	 <p>Tx7 L-Shaped Wrench (1 pc)</p>	 <p>Thermal Grizzly Conductionaut Liquid Metal Thermal Paste - (1 G) (1 pc)</p>
 <p>Thermal Grizzly Ryzen 7000 Delid-Die-Mate EAN: 3831109905685</p>	 <p>Thermal Grizzly TG Shield EAN: 3831109907337</p>	 <p>Velocity² Mounting Screw AM5 (Ni)</p>	 <p>TX20 L-Shaped Wrench (1 pc)</p>

BOX CONTENTS AMD Ryzen Edition

Mounting Mechanism EAN: 107603

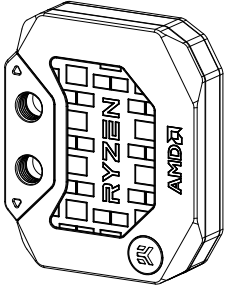

EK-Quantum Velocity² Direct Die
D-RGB - AMD Ryzen Edition



Die Guard (1 pc)



Allen Key 2 mm (1 pc)



Allen Key 2.5 mm (1 pc)

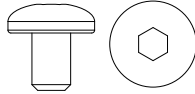

Screw UNC 6/32x5 (4 pcs)



Tx7 L-Shaped Wrench (1 pc)

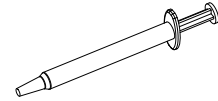

Thermal Grizzly Conductionaut Liquid
Metal Thermal Paste - (1 G) (1 pc)

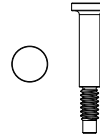

Velocity² Mounting Screw AM5 (Ni)



TX20 L-Shaped Wrench (1 pc)

WATER BLOCK DIMENSIONS

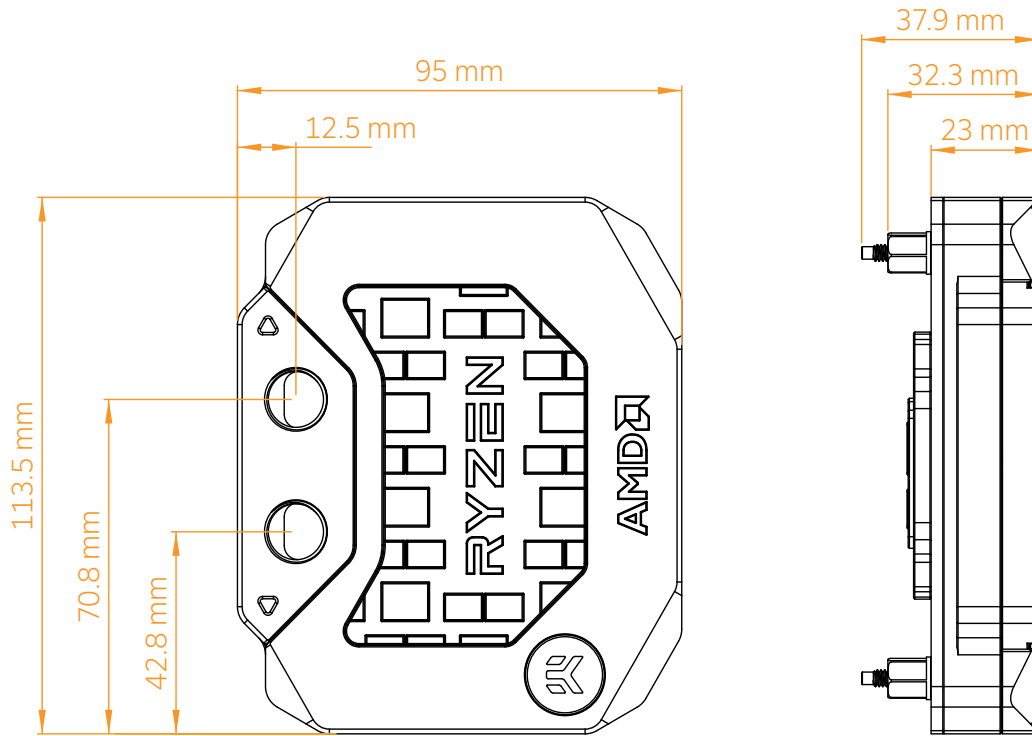

TEHNICAL SPECIFICATIONS AND WATER BLOCK PARTS

Technical Specification:

Dimensions (L x H x W): 113.5 x 95 x 38 mm

D-RGB cable length: 500 mm

D-RGB LED count: 14

D-RGB connector standard 3-pin (+5V, Data, Blocked, Ground)

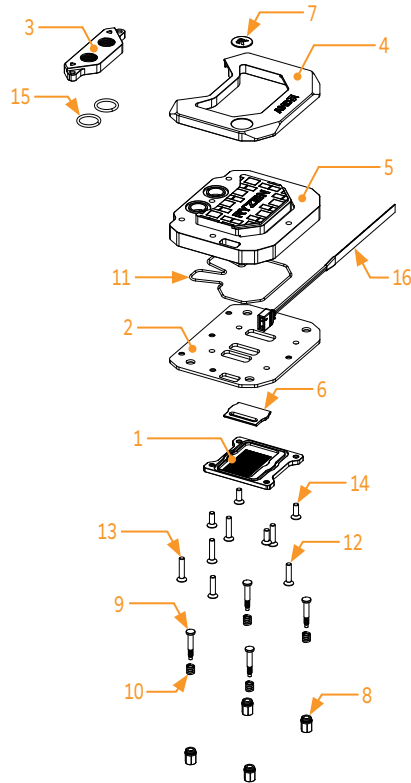

Position	EAN	Description	Quantity
1	107636	Coldplate DD (Nickel)	1
2	106719	Metal Plate	1
3	106720	Terminal (Acetal)	1
4	106718	Cover (Aluminium)	1
5	106721	Top plate (Plexi)	1
6	106724	Jet Plate	1
7	100663	EK Badge	1
8	106900	Standoff	4
9	107066	Mounting Screw	4
10	8706	Mounting Spring	4
11	107571	OR 85 x 1.5 mm	1
12	9039	Screw M4 x 18 DIN7991	3
13	8210	Screw M4 x 20 DIN7991	3
14	8206	Screw M4 x 12 DIN7991	4
15	105835	OR 15 x 2 mm	2
16	103007	LED Strip	1

DELIDING THE CPU

STEP 1

For delidding the CPU, EK recommends the use of Thermal Grizzly Ryzen 7000 Delid-Die-Mate.

For additional information on delidding, preparing, and installing the CPU, please check out the video link provided on the product page: <https://www.ekwb.com/shop/ek-quantum-velocity2-direct-die-d-rgb-amd-ryzen-edition>

PREPARING THE CPU

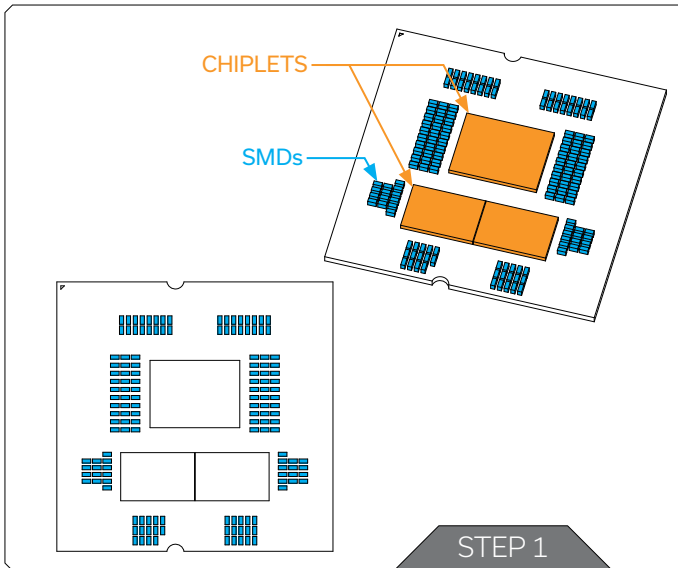

STEP 1

Clean all the remaining adhesive from the CPU PCB and CPU Chiplets.

After cleaning, protect the SMDs (marked in the drawing) using the provided Thermal Grizzly TG Shield.



Thermal Grizzly TG Shield is a protective coating used to safeguard against liquid metal or other electrically conductive heat transfer agents at high temperatures.

Apply a thick layer of TG Shield on the SMDs with the integrated brush. Let it dry and repeat until the SMDs are covered.

For this step, you will need:

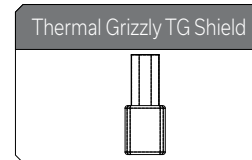

PREPARING THE MOTHERBOARD

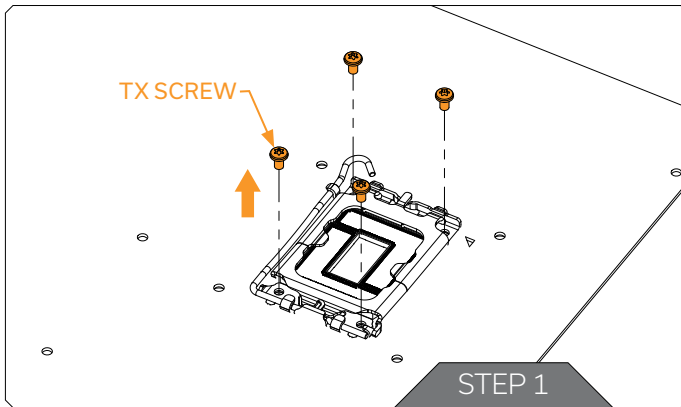

STEP 1

Remove the stock Torx screws from the motherboard. For this step, you must use TX20 Key (included in the mounting bag)

For this step, you will need:

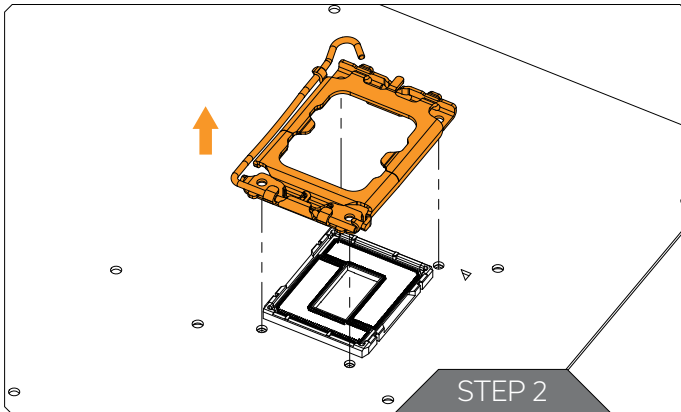
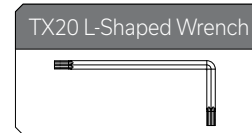

STEP 2

Remove the CPU mounting mechanism from the motherboard.

Do not remove the stock backplate.

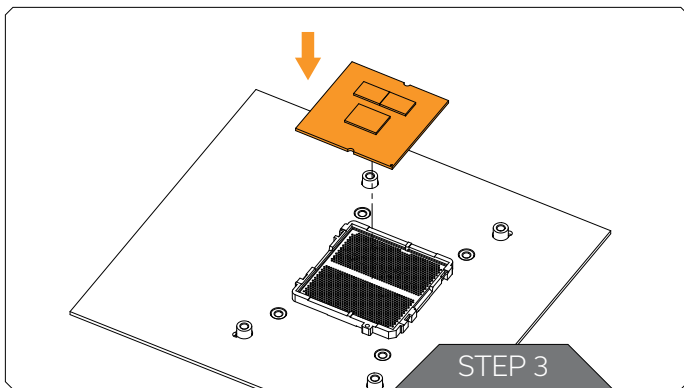

STEP 3

Install the pre-prepared delidded CPU in the socket. Be careful not to touch the Chiplets and SMD-s.

INSTALLING THE DIE GUARD AND APPLYING THE PASTE

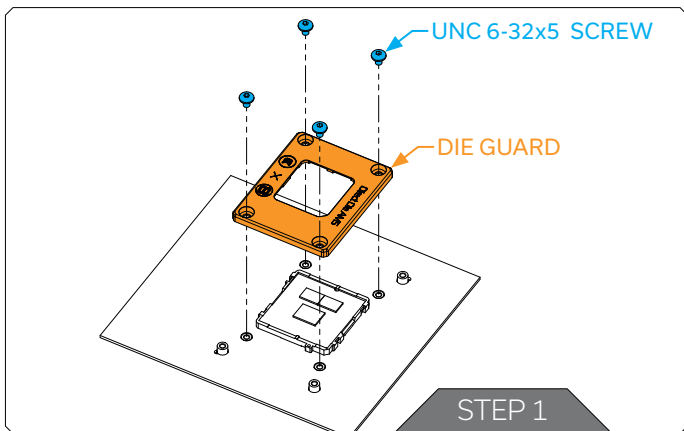

STEP 1

Place the Die Guard on the motherboard (make sure to align the mounting holes). Secure the Die Guard using the UNC 6-32x5 screws.



Do not remove the protective sticker from the DIE GUARD.

For this step, you will need:

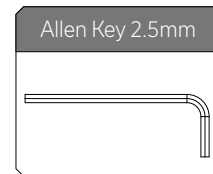
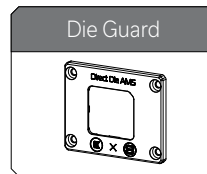
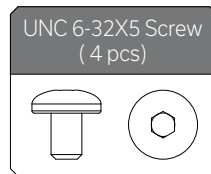

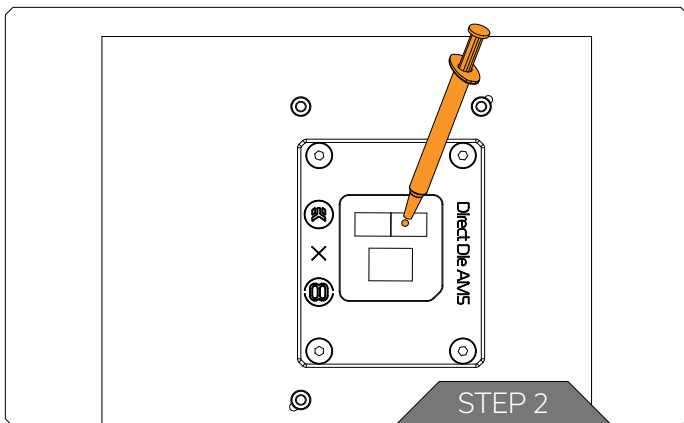

STEP 2

Apply a small drop of Thermal Grizzly Conductonaut liquid metal paste and spread it evenly over the DIE-s with cotton swabs that are included in the bag. Use the provided needle accessory that is included in the bag.

Don't press the syringe too hard! Use the provided needle accessory that is included in the bag.

For more information read the Thermal Grizzly Conductonaut instructions.



In case of over-application of Thermal Grizzly Conductonaut liquid metal, clean the DIE and reapply it. Otherwise, over time, the performance of the water block may deteriorate.

INSTALLING THE CPU WATER BLOCK

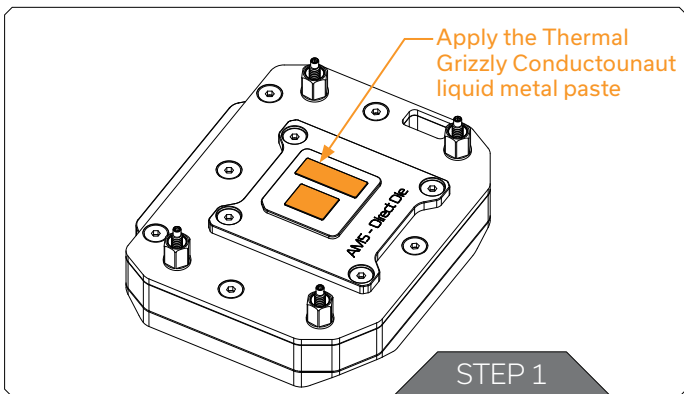

STEP 1

Apply a small drop of Thermal Grizzly Conductonaut liquid metal and spread it on the block.

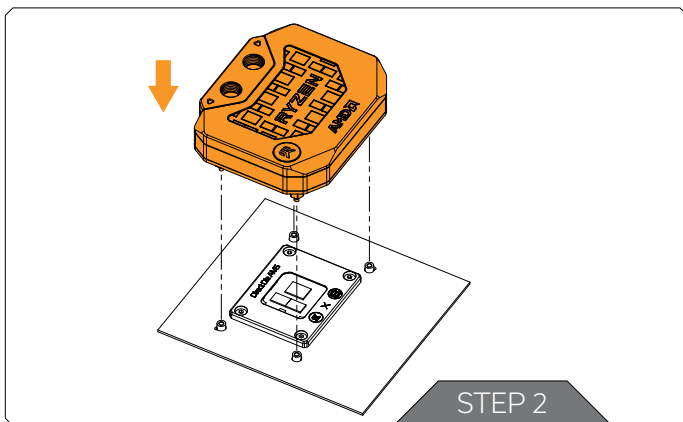

STEP 2

Position the CPU block onto the motherboard. Make sure to align the holes (as shown in the picture).

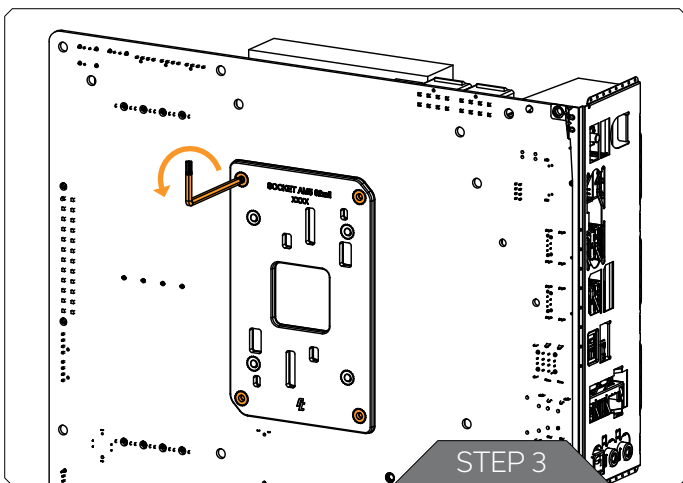

STEP 3

Secure the water block from the backside of the motherboard using the included Tx7 L-Shaped wrench.

Tighten the mounting screws in an anti-clockwise direction. Start fastening the screws in a cross pattern. Do not tighten fully until all of the screws are partially screwed in.

The Tx7 L-Shaped wrench must be used in a standing position! Otherwise, the mounting screws may crack during tightening!

For this step, you will need:

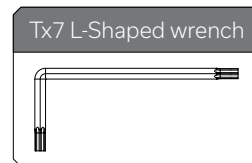

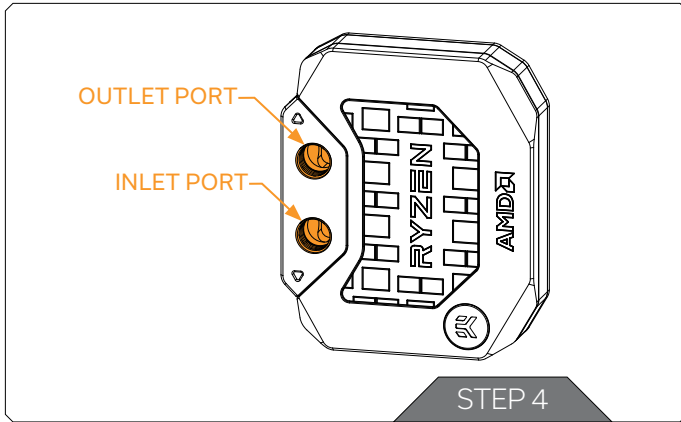

STEP 4

With EK-Velocity² series water blocks, it is mandatory to use the bottom port as the INLET. Mixing the ports may result in poor thermal performance of the water block. Tighten the fittings in clockwise direction until the gasket underneath is compressed.

CONNECTING THE D-RGB LED STRIP

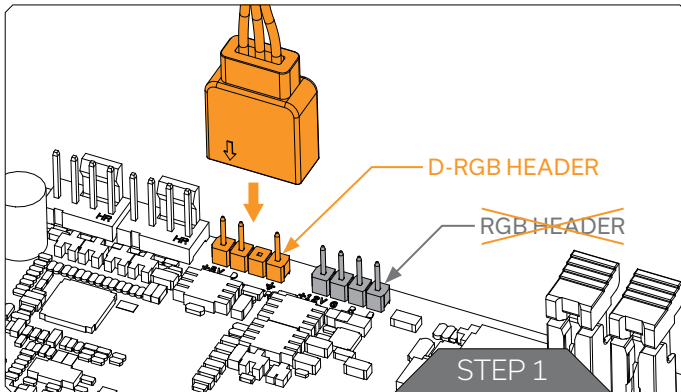

STEP 1

Plug the 3 Pin connector from the water block's D-RGB LED light to the DRGB HEADER on the motherboard. The LED will work if the pin layout on the header is as follows: +5V, Digital, empty, Ground.



Please ensure that the arrow indicated on the connector is plugged into the +5V line as indicated on your motherboard. If you put the LED Diode to the 12V RGB HEADER you can damage the LEDs. Failure to do so will damage your motherboard or LED strip.

SUPPORT AND SERVICE

In case you need assistance or wish to order spare parts or a new mounting mechanism, please contact:

<https://www.ekwb.com/customer-support/>

For spare parts orders, refer to the page with "TECHNICAL SPECIFICATIONS AND WATER BLOCK PARTS" where you can find the EAN number of each part you might need.

Include the EAN number with quantity in your request. Mounting Mechanism EAN can be found under "BOX CONTENTS"

Thermal pads are readily available in the EK shop

SOCIAL MEDIA

 EKWaterBlocks

 @EKWaterBlocks

 ekwaterblocks

 EKWBofficial

 ekwaterblocks

