

# EK-Quantum Momentum<sup>2</sup> ROG Maximus Z790 Extreme D-RGB - Special Edition

MONOBLOCK

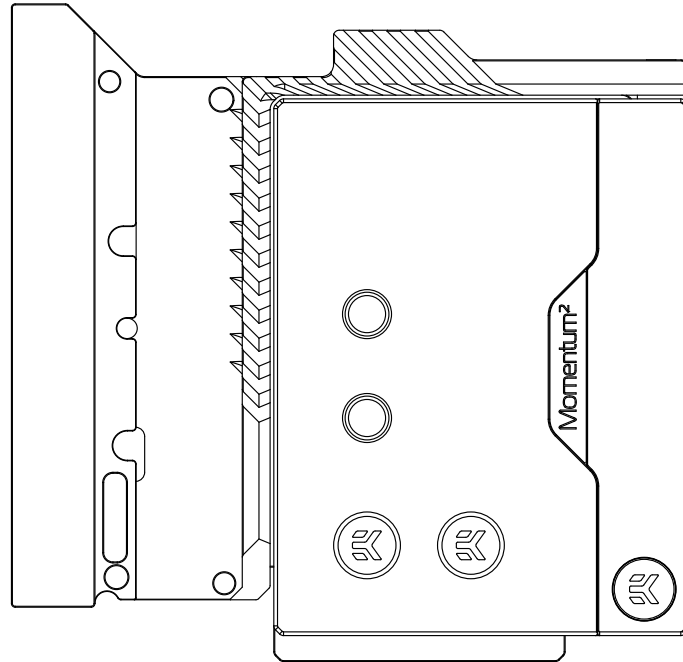

Please note the installation of the product is intended to be undertaken by an adequately trained and experienced person. You are installing the product at your own risk. If you are not properly trained or experienced or feel unsure about the installation procedure, please refrain from installing the product yourself and contact our tech support for assistance. We disclaim our liability for any damages to the product as well as incidental, consequential, or indirect damages incurred due to improper or inappropriate installation.

Before you start using this product, please follow these basic guidelines:

**Carefully read the manual before beginning with the installation process.**

**Remove your motherboard from the computer for the safest mounting process to prevent any possible damage to your water block or its circuit board (PCB).**

**The EK Fittings require only a small amount of force to screw them firmly in place since the liquid seal is ensured by the rubber O-ring gaskets.**

**The use of corrosion-inhibiting coolants is always recommended for liquid cooling systems and mandatory for nickel-plated water blocks!**

**Do not use pure distilled water!**

**For best results, EK recommends the use of EK-CryoFuel coolants! To reach optimal performance, make sure to thoroughly bleed the air out of your water block!**

# TABLE OF CONTENTS

<b>BOX CONTENTS</b>	<b>4</b>
<b>WATER BLOCK DIMENSIONS</b>	<b>6</b>
<b>TECHNICAL SPECIFICATIONS AND WATER BLOCK PARTS</b>	<b>7</b>
<b>PREPARING THE MOTHERBOARD</b>	<b>8</b>
REMOVING THE BACKPLATE	8
REMOVING THE STOCK COOLER	9
INSTALLING THE CPU AND DIE GUARD	10
<b>ATTACHING THE REPLACEMENT COVER</b>	<b>11</b>
<b>INSTALLING THE WATER BLOCK</b>	<b>13</b>
CUTTING AND PLACING THERMAL PADS	13
APPLYING THERMAL COMPOUND	14
PLACING THE WATER BLOCK	14
CONNECTING THE 10-PIN SIGNAL SPLITTER	16
CONNECTING THE D-RGB LED STRIP	17
ATTACHING THE REPLACEMENT I/O COVER (IF USING ACTIVE BACKPLATE SET)	17
<b>FITTINGS AND TUBING</b>	<b>18</b>
<b>TESTING THE LOOP</b>	<b>18</b>
<b>SUPPORT AND SERVICE</b>	<b>19</b>
<b>SOCIAL MEDIA</b>	<b>19</b>

# BOX CONTENTS

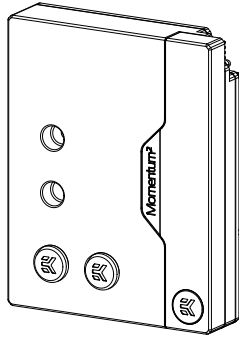

EK-Quantum Momentum² ROG Maximus Z790 Extreme D-RGB-Special Edition + Mounting mechanism

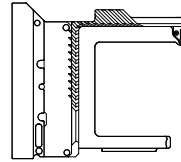

Replacement cover (1 pc)

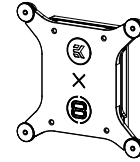

Die guard + Backplate Assembly (1 pc)

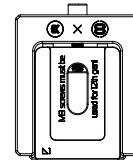

Delidding Tool (1 pc)



Replacement I/O cover (1 pc)

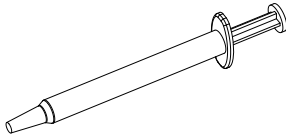

Thermal Grizzly Conductionaut (1 pc)



10pin Signal Splitter (1 pc)

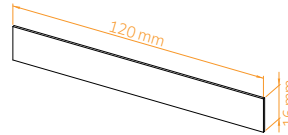

Thermal Pad F 0.5 mm (3 pcs)

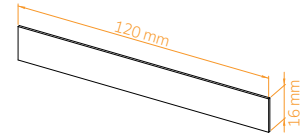



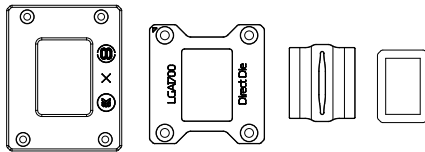

Thermal Pad F 1.5 mm (5 pcs)



Direct die Upgrade kit (1 pc)

**EK-Quantum Momentum<sup>2</sup> ROG Maximus Z790 Extreme D-RGB - Special Edition - Mounting mechanism**

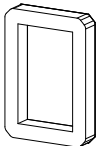
EAN: 106546

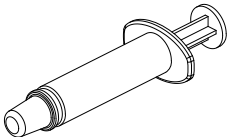
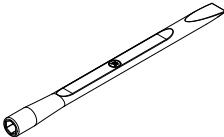
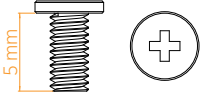
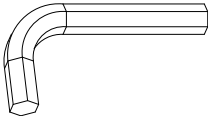
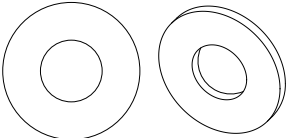
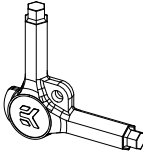
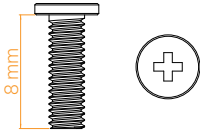
 <p>Allen Key 2 mm (1 pc)</p>	 <p>Allen Key 2.5 mm (1 pc)</p>	 <p>Protective sticker (1 pc)</p>	 <p>Protective Foam 5 mm (1 pc)</p>
 <p>TX20 Key (1 pc)</p>	 <p>Thermal Grease (1 pc)</p>	 <p>EK-Plug Out Spludger Tool (1 pc)</p>	 <p>Screw M2.5x5 mm (10 pcs)</p>
 <p>Allen Key 5 mm (1 pc)</p>	 <p>PVC Washer M2.5 (10 pcs)</p>	 <p>EK-Loop Multi Allen Key (1 pc)</p>	 <p>Screw M2.5x8 mm (1 pc)</p>

# WATER BLOCK DIMENSIONS

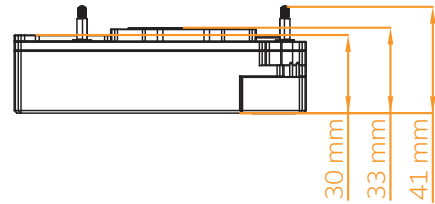
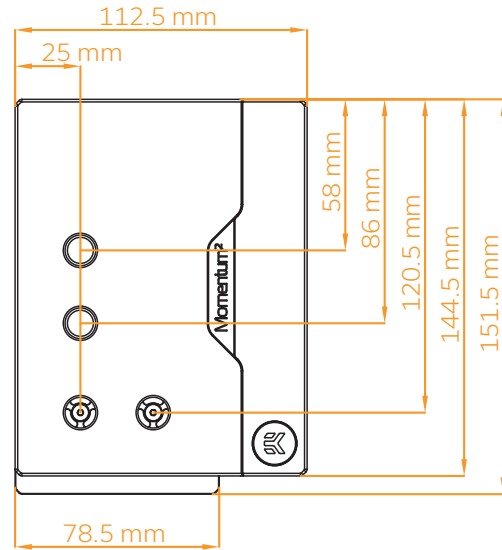
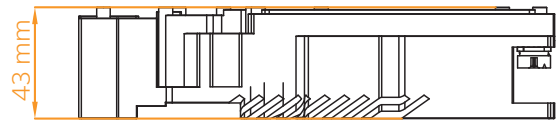
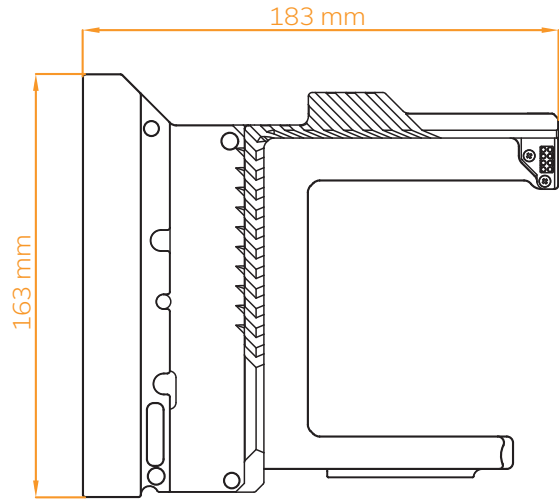

## TECHNICAL SPECIFICATIONS AND WATER BLOCK PARTS

### Technical Specification:

- Dimensions: (L x H x W) - 151.5 x 112.5 x 33 mm
- D-RGB cable length: 500 mm
- D-RGB LED count: 8
- D-RGB connector standard 3-pin (+5V, Data, Blocked, Ground)

Position	EAN	Description	Quantity
1	106545	OR - Momentum2 Z790 Maximus Extreme SE	1
2	8204	Screw M3 x 20 7991DIN	3
3	102663	Screw M3 x 10 7991DIN	17
4	104774	OR - 6 x 1.5 mm	1
5	8202	Screw M3 x 12 DIN7991	2
6	106530	M.2 HeatBridge (Bl. Elox)	1
7	3831109834282	Plug Cover - Black	2
8	102639	Quantum Plug	2
9	104115	Temperature Probe	2
10	9047	Screw M2.5 x 4 AX1	2
11	105304	LED D-RGB strip	1
12	102478	PCB - Hall Sensor	1
13	102543	Screw M2.5 x 3 AX1	2
14	106542	PCB board	1
15	106654	Valve Cap	2
16	106653	Spring Retainer Screw	2
17	106835	Spring 5.6 x 24.3 (14N)	2
18	106847	Screw -Flowmeter impeller	1
19	102251	Flowmeter impeller	1
20	100663	EK - Badge	1
21	104444	Mylar sticker	1
22	103091	Screw M3 x 8 ISO 14581 Tx	1
23	106540	Valve Midplate	1
24	106537	Standout (Acetal)	1
25	106536	Top Cover	1
26	106841	Midplate Assembly	1
27	104686	Screw M4 x 14 7991DIN	4
28	104029	Jet Plate	1
29	104028	Coldplate (Ni)	1
30	104773	Coldplate OR	1
31	3830046998446	Thermal grease	1

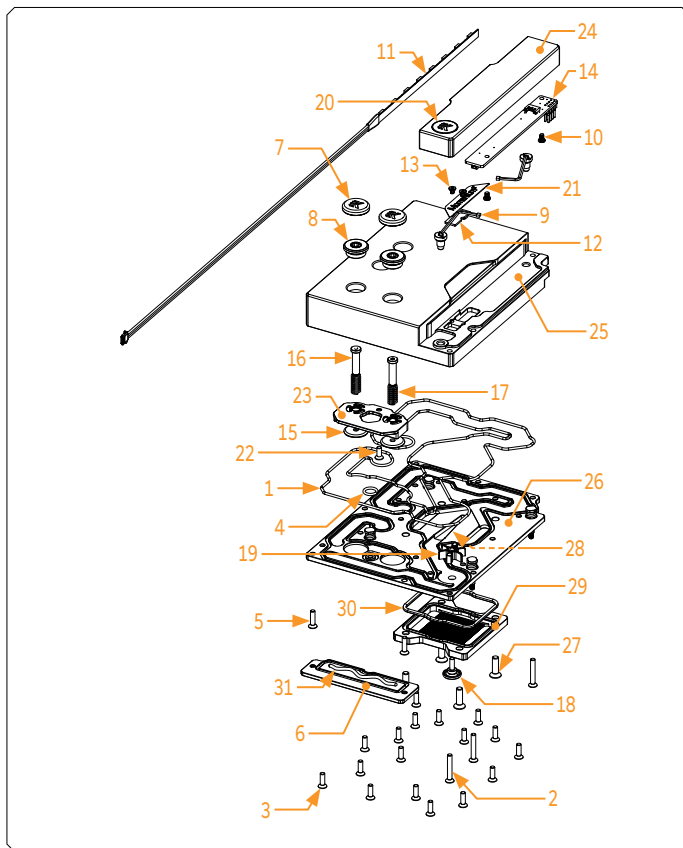

## PREPARING THE MOTHERBOARD

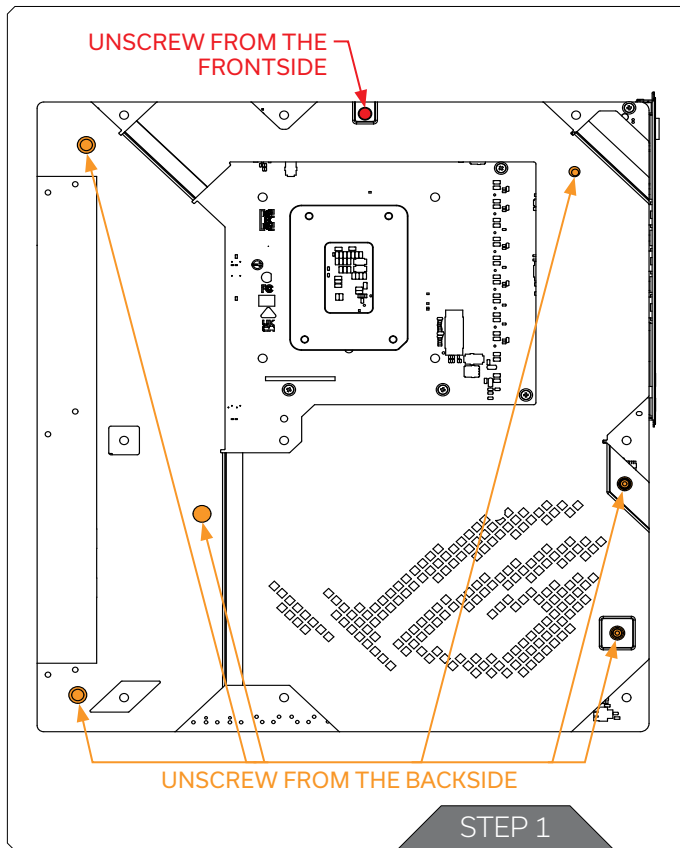

Important! Before starting, make sure to have a clean, flat surface to work on. Putting foam or soft material to lay the motherboard on is recommended.

### STEP 1 REMOVING THE BACKPLATE

Using a Philips head screwdriver, unscrew six (6) Screws. Rotate the motherboard and remove an additional one (1) screw (Red marked in the picture).

Carefully detach the connectors from the motherboard and remove the backplate. Save the screws. After installation of the Monoblock, you can reuse the backplate.

For this step, you will need:

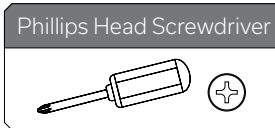



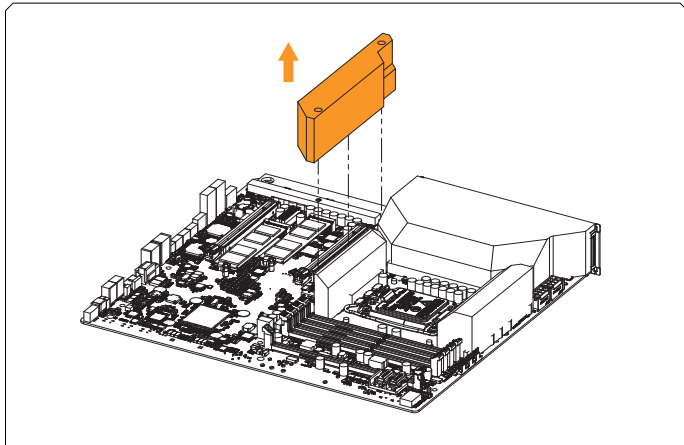

## STEP 2 REMOVING THE STOCK COOLER

From the front side of the motherboard, unscrew two (2) screws located in the SSD heatsink. Rotate the motherboard and unscrew eight (8) screws from the back of the motherboard. Detach the stock cooler from the motherboard.

Save the I/O Screen for later use – it can be reused at the end of the installation.

For this step, you will need:

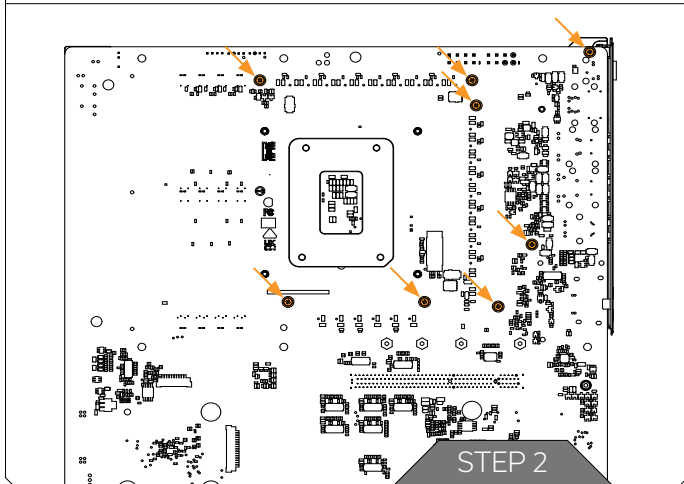
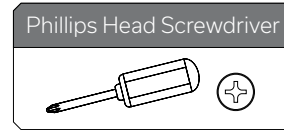

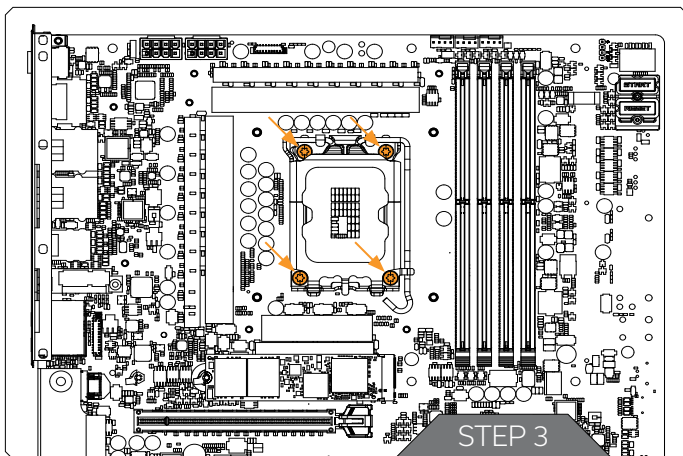

### STEP 3

#### REMOVING THE CPU SOCKET (MOUNTING MECHANISM)

Remove the Tx screws (marked in the picture) and detach the CPU socket mounting mechanism.

For this step you will need:

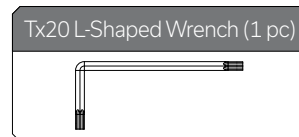

### STEP 4

#### INSTALLING THE CPU AND DIE GUARD

First, unscrew (4) M3 x 12 DIN7991 Screws from the Die guard + Backplate Assembly.

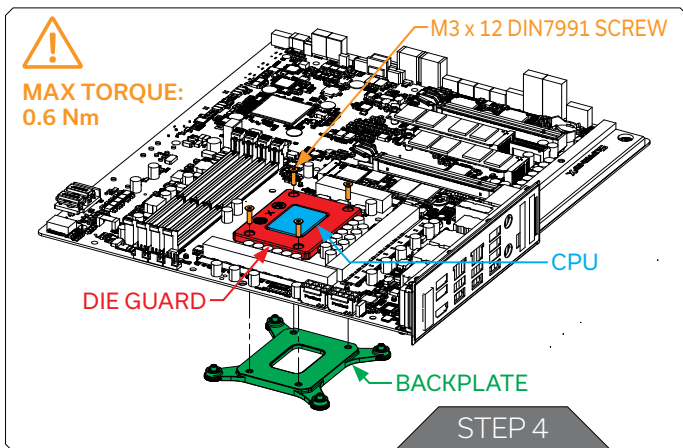

After that, position the CPU and Die Guard on the motherboard. Align the holes on the motherboard with the holes on the die guard. On the back of the motherboard place the Backplate. Use four (4) M3 x 12 DIN7991 Screws to secure the Assembly.

EK recommends using the EK-Loop Torque Screwdriver - 0.6Nm:  
<https://www.ekwb.com/shop/ek-loop-torque-screwdriver-0-6nm>

In case of delidding the CPU, please follow the link:  
<https://www.youtube.com/watch?v=258mCuhm650>

For this step, you will need:

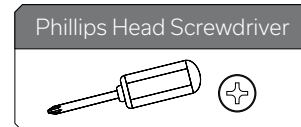
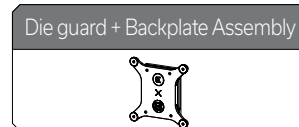

## ATTACHING THE REPLACEMENT COVER

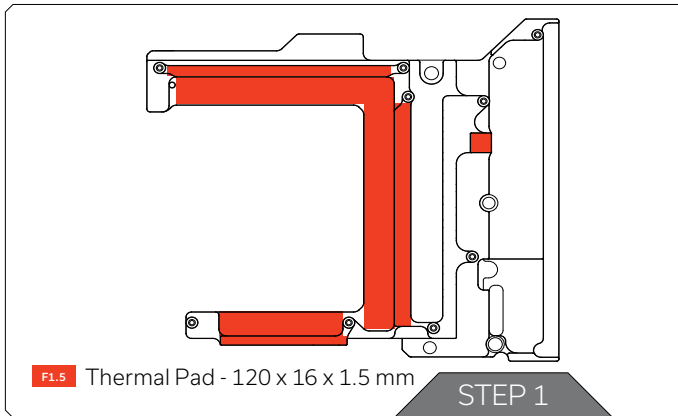

### STEP 1



The replacement cover must be attached before installing the Monoblock.

Place the F1.5 mm thermal pads (as shown in the picture) onto the replacement cover. EK made sure to provide you with more than an adequate quantity of Thermal Pads to complete this Step.



**CAUTION:** You must remove the protective foil from both sides of the thermal pad before installation.

Required thermal pads:

Thermal Pad F 1.5 mm – (120 x 16 mm) EAN: 3830046996749

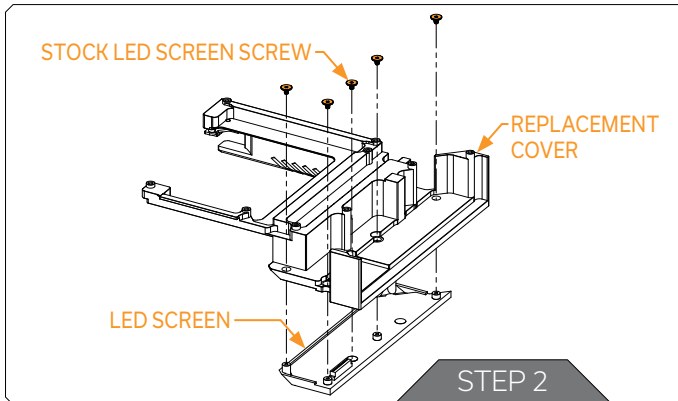

### STEP 2

The LED screen from the stock cooler must be attached to the replacement cover before securing the cover.

After installation of the LED screen, connect the cable from the LED screen to the motherboard.

For this step, you will need:

Phillips Head Screwdriver

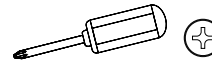

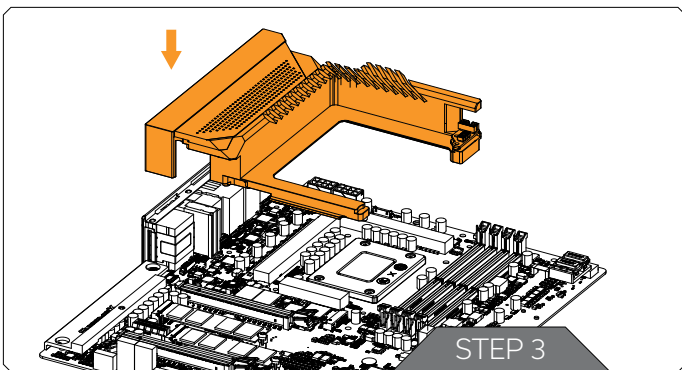

### STEP 3

Place the replacement cover onto the motherboard. Make sure to align the mounting holes on the motherboard with the standoffs on the cover.

Make sure the LED screen is correctly connected to the motherboard.

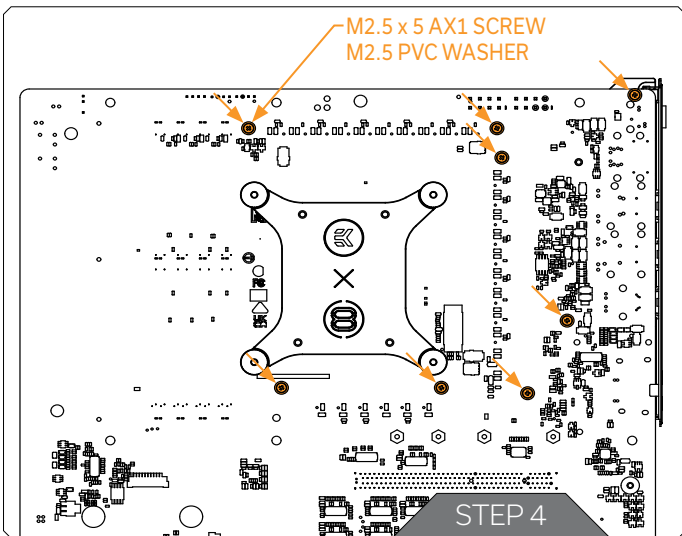

### STEP 4

Rotate the motherboard and attach the replacement cover with the provided mounting screws. Make sure to select the correct screw for each standoff (screw lengths are marked in the picture).

For this step you will need:

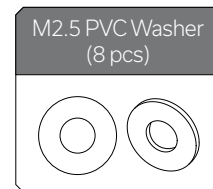
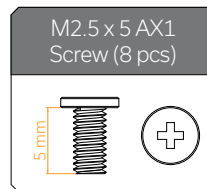
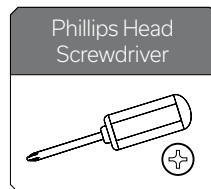

# INSTALLING THE WATER BLOCK

**F0.5** Thermal Pad - 120 x 16 x 0.5 mm

**F1.5** Thermal Pad - 120 x 16 x 1.5 mm

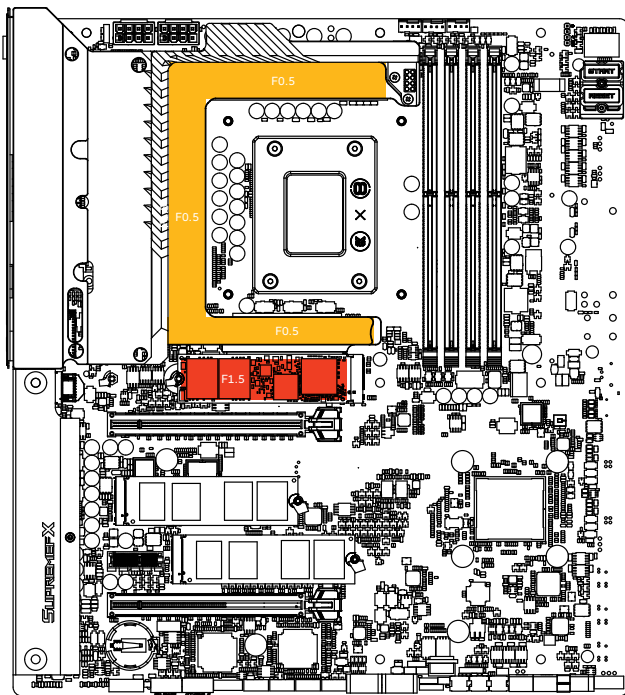

STEP 1

## STEP 1

### CUTTING AND PLACING THERMAL PADS

After attaching the replacement cover, a few additional thermal pads must be placed in the places marked in the picture. EK made sure to provide you with more than an adequate quantity of Thermal Pads to complete this Step.



**CAUTION:** You must remove the protective foil from both sides of the thermal pad before installation.



Before placing the thermal pads, install the M.2 SSD disc.

Replacement thermal pads:

Thermal Pad F 0.5 mm - (120 x 16 mm) EAN: 3830046996725

Thermal Pad F 1.5 mm - (120 x 16 mm) EAN: 3830046996749

For this step, you will need:

Scissors

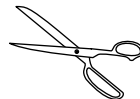

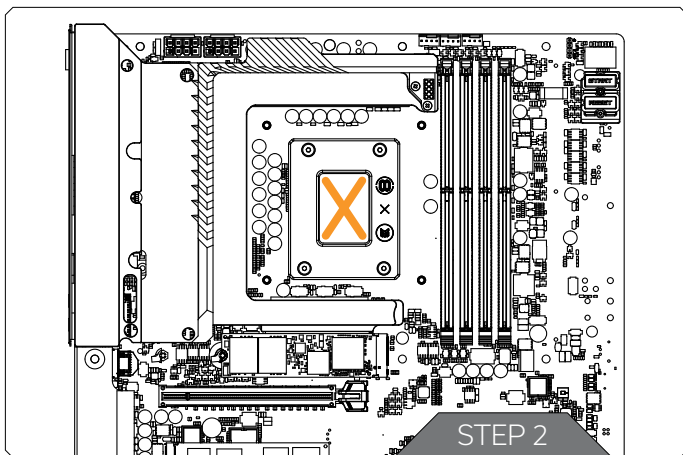

## STEP 2 APPLYING THERMAL COMPOUND

Apply the enclosed thermal grease (thermal compound) on the CPU heat spreader - IHS - as shown in the image. The layer of the thermal compound must be thin and even in thickness over the entire surface of the IHS.



The excessive or uneven application of thermal grease may lead to poor performance!

For this step, you will need:

Thermal Grease

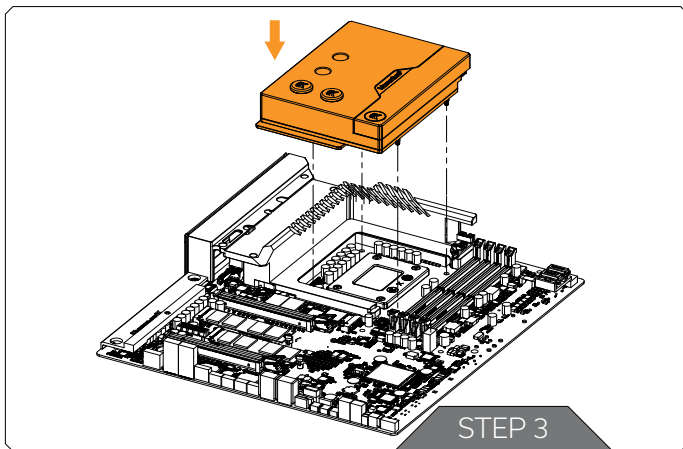
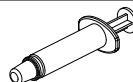

## STEP 3 PLACING THE WATER BLOCK

Place the water block onto the motherboard. **Make sure to align the holes on the motherboard with the Monoblock standoffs. Also, make sure that the pins on the replacement cover and water block are aligned!**

**Double-check the layer of the thermal compound and thermal pads before placing the water block!**



**Before placing the water block onto the motherboard, install the M.2 SSD disc.**

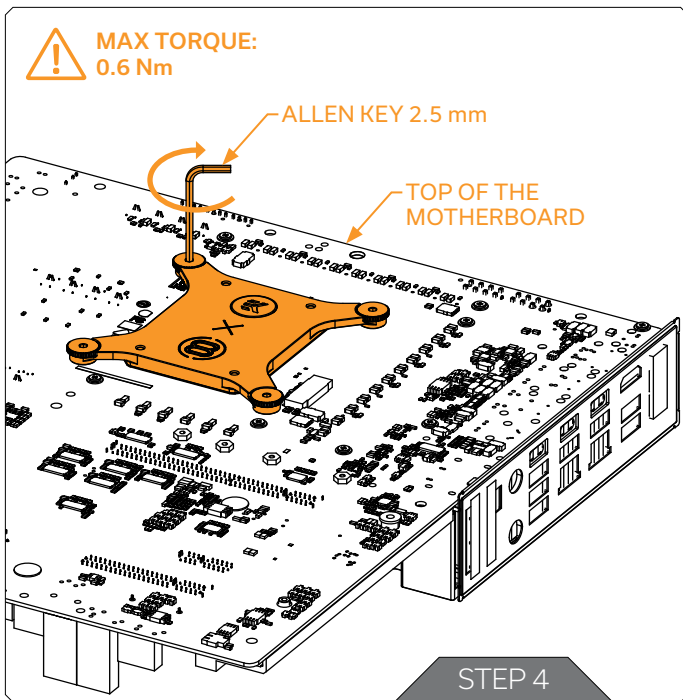

#### STEP 4

After placing the water block, fasten the backplate screws in a cross pattern. Do not tighten fully until all of the nuts are partially screwed in.



Make sure to orientate the backplate as illustrated. Incorrect installation of the backplate may result in damage to the motherboard.



In the case of using the Allen Key 2.5mm, it must be used in a standing position! Otherwise, the mounting screws may crack during tightening!



EK also recommends using the EK-Loop Torque Screwdriver - 0.6Nm:  
<https://www.ekwb.com/shop/ek-loop-torque-screwdriver-0-6nm>

For this step you will need:

Allen Key 2.5mm

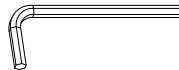

## STEP 5 CONNECTING THE 10-PIN SIGNAL SPLITTER

Connect the 10-pin signal splitter connector to the Monoblock.



Please ensure that the arrow indicated on the connector is plugged into the line as indicated on your Monoblock.

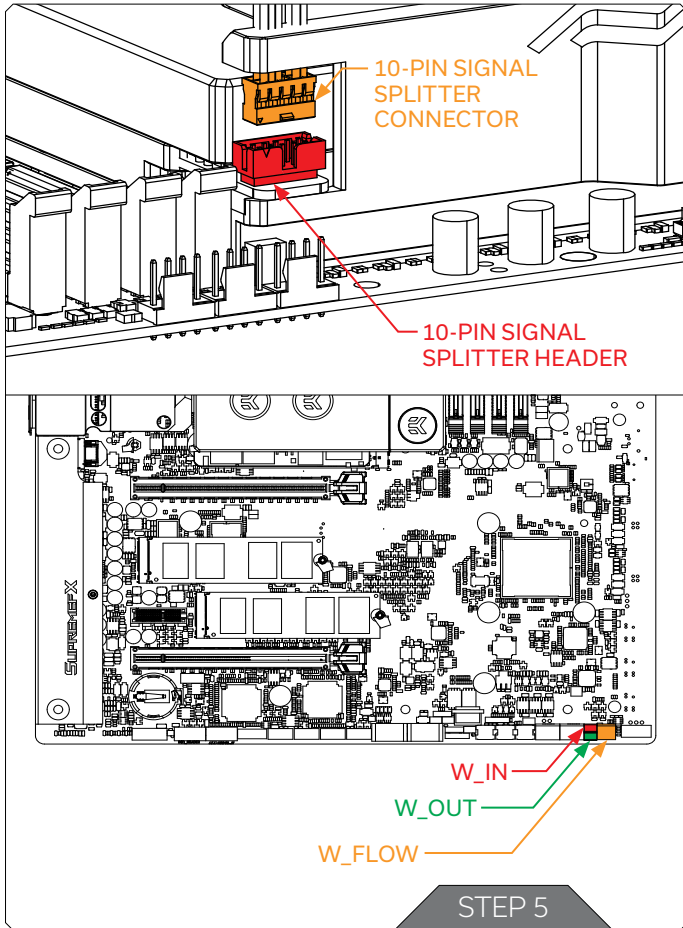

The opposite side of the connector must be connected to the motherboard (marked in the picture).



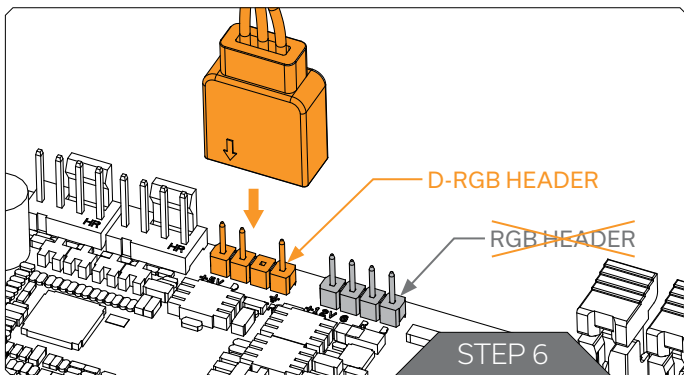

## STEP 6

### CONNECTING THE D-RGB LED STRIP

Plug the 3-Pin connector from the water block's D-RGB LED light to the DRGB HEADER on the motherboard. The LED will work if the pin layout on the header is as follows: +5V, Digital, empty, Ground.



Please ensure that the arrow indicated on the connector is plugged into the +5V line as indicated on your motherboard. If you put the LED Diode to the 12V RGB HEADER you can damage the LEDs. Failure to do so will damage your motherboard or LED strip.

## STEP 7 (Optional)

### ATTACHING THE REPLACEMENT I/O COVER (IF USING ACTIVE BACKPLATE SET)

In order to install the Replacement I/O Cover, follow the link:  
<https://www.ekwb.com/shop/EK-IM/EK-IM-3831109908327.pdf>

## FITTINGS AND TUBING

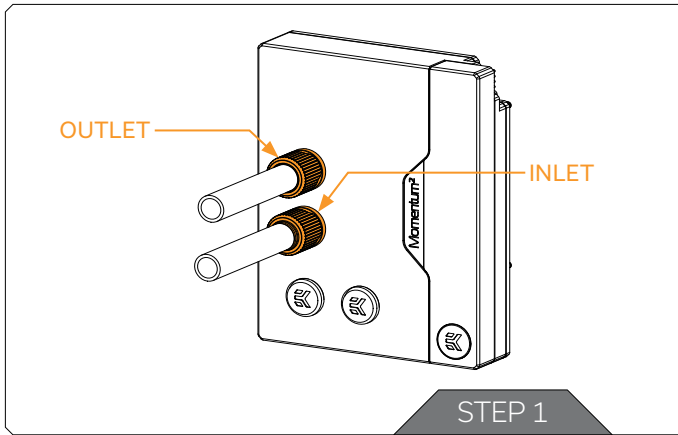

### STEP 1

Several tubing configurations are possible for this Monoblock. For more information, check the product page: <https://www.ekwb.com/shop/ek-quantum-momentum2-rog-maximus-z790-extreme-d-rgb-special-edition>

The basic configuration is described below.

**Option 1:** In the shown configuration, it is mandatory to use the bottom port as the INLET. Mixing the ports may result in poor thermal performance of the water block. Tighten the fittings in a clockwise direction until the gasket underneath is compressed. The remaining ports must be closed with the provided G1/4 plugs.

## TESTING THE LOOP

To make sure the installation of EK components was successful, we recommend you perform a leak test for 24 hours. When your loop is complete and filled with coolant, connect the pump to a PSU outside of your system. Do not connect power to any of the other components. Turn on the PSU and let the pump run continuously. It is normal for the coolant level to drop during this process as air collects in the distribution plate. Inspect all parts of the loop, and in the eventuality, that coolant leaks, fix the issue and repeat the testing process. Ensure that all hardware is dry before the system is powered on in order to prevent any damage.

## SUPPORT AND SERVICE

In case you need assistance or wish to order spare parts or a new mounting mechanism, please contact:

**<https://www.ekwb.com/customer-support/>**

For spare parts orders, refer to the page with "TECHNICAL SPECIFICATIONS AND WATER BLOCK PARTS" where you can find the EAN number of each part you might need.

Include the EAN number with quantity in your request. Mounting Mechanism EAN can be found under "BOX CONTENTS"

Thermal pads are readily available in the EK shop

## SOCIAL MEDIA

 EKWaterBlocks

 @EKWaterBlocks

 ekwaterblocks

 EKWBofficial

 ekwaterblocks

