

# **EK-Quantum Velocity Ryzen Edition UNC Standoffs - AM5**



Please note the installation of the product is intended to be undertaken by an adequately trained and experienced person. You are installing the product at your own risk. If you are not properly trained or experienced or feel unsure about the installation procedure, please refrain from installing the product yourself and contact our tech support for assistance. We disclaim our liability for any damages to the product as well as incidental, consequential, or indirect damages incurred due to improper or inappropriate installation.

Before you start using this product, please follow these basic guidelines:

**Please carefully read the manual before beginning the installation process.**

**The EK Fittings require only a small amount of force to screw them firmly in place since the liquid seal is ensured by the rubber O-ring gaskets.**

**The use of corrosion-inhibiting coolants is always recommended for liquid cooling systems, and mandatory for nickel-plated water blocks.**

**Do not use pure distilled water! For best results, EK recommends the use of EK-Cryo Fuel coolants.**

**Make sure to thoroughly bleed air out of your water block, or you will not reach optimal performance.**

# TABLE OF CONTENTS

<b>BOX CONTENTS</b>	<b>4</b>
<b>PREPARING THE AM4 WATER BLOCK FOR UPGRADE</b>	<b>4</b>
<b>PREPARING THE AM5 MOTHERBOARD</b>	<b>5</b>
<b>INSTALLING THE WATER BLOCK</b>	<b>7</b>
<b>CONNECTING THE D-RGB LED STRIP</b>	<b>8</b>
<b>TESTING THE LOOP</b>	<b>8</b>
<b>WARRANTY</b>	<b>9</b>
<b>SUPPORT AND SERVICE</b>	<b>10</b>
<b>SOCIAL MEDIA</b>	<b>10</b>

## BOX CONTENTS



AM5 Mounting Standoff (4 pcs)

## PREPARING THE AM4 WATER BLOCK FOR UPGRADE

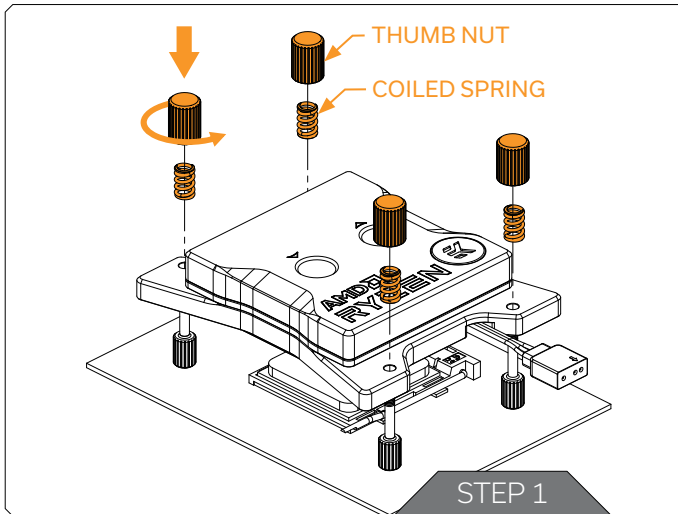

**Important!** Before starting, make sure to have a clean, flat surface to work on. It is recommended to put foam or soft material to lay a motherboard on.

### STEP 1

If the EK-Quantum Velocity Ryzen AM4 water block is already installed, unscrew four (4) Thumb Nuts to detach it (As shown in the picture). Save the parts for later use.

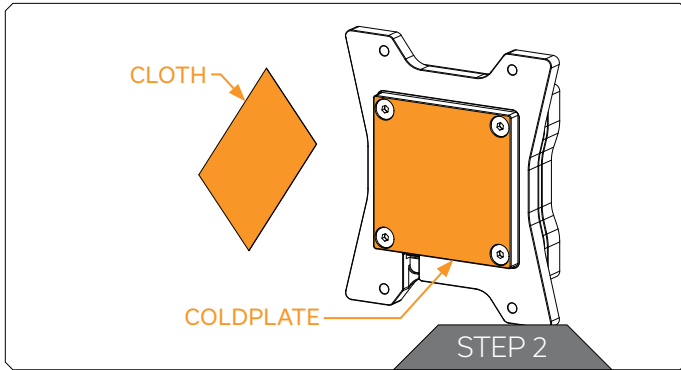

## STEP 2

Clean the CPU cold plate using a non-abrasive cloth or Q-tip.

## PREPARING THE AM5 MOTHERBOARD

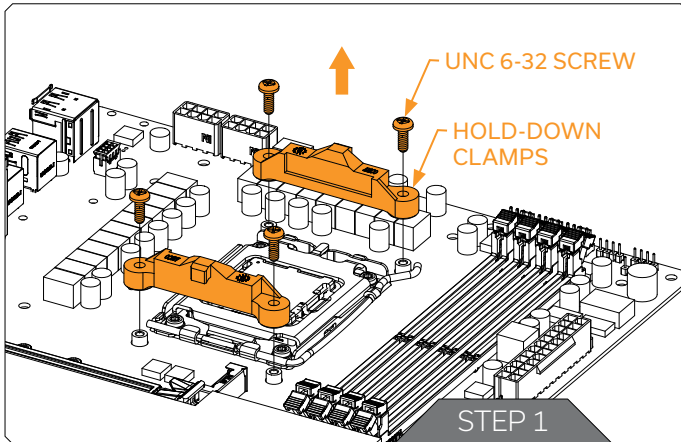

## STEP 1

Using a Philips-head screwdriver remove the four UNC 6-32 screws securing the original plastic hold-down clamps around the socket as shown in the illustration. Remove the hold-down clamps and store them away.

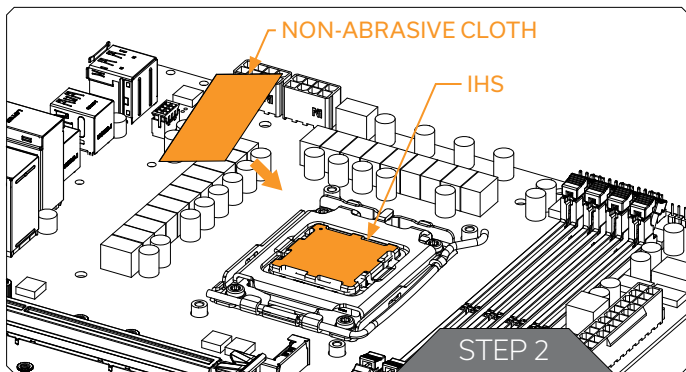

## STEP 2

**Cleaning the CPU:** Wipe the IHS clean using a non-abrasive cloth or Q-tip as shown in the illustration.

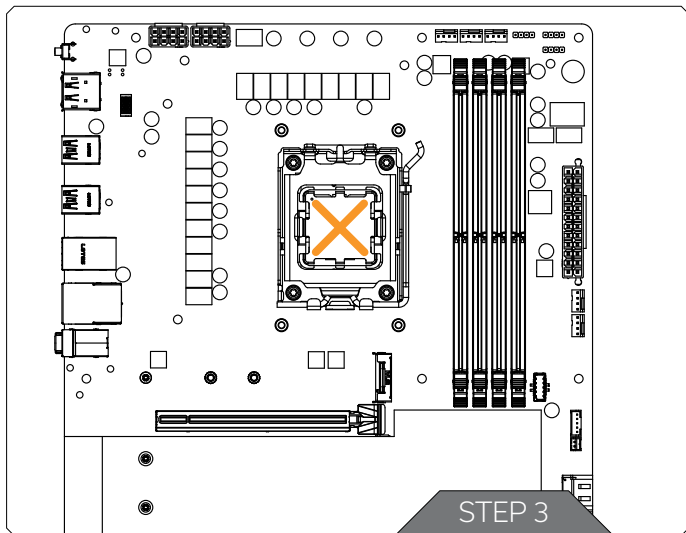

## STEP 3

**Applying thermal compound:** Apply the enclosed thermal grease (thermal compound) on the CPU heat spreader - IHS - as shown in the image. The layer of the thermal compound must be thin and even in thickness over the entire surface of the IHS.



The excessive or uneven application of thermal grease may lead to poor performance!

For this step, you will need:

Thermal Grease

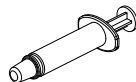

## INSTALLING THE WATER BLOCK

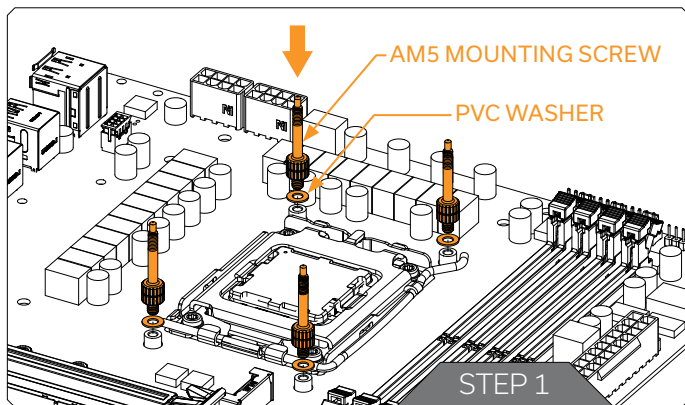

### STEP 1

Install four (4) AM5 Mounting screws onto your motherboard. It is mandatory to put a saved plastic washer underneath each of the screws. Tighten the screws until you reach the end of the thread. Using tools (such as pliers) is not recommended.

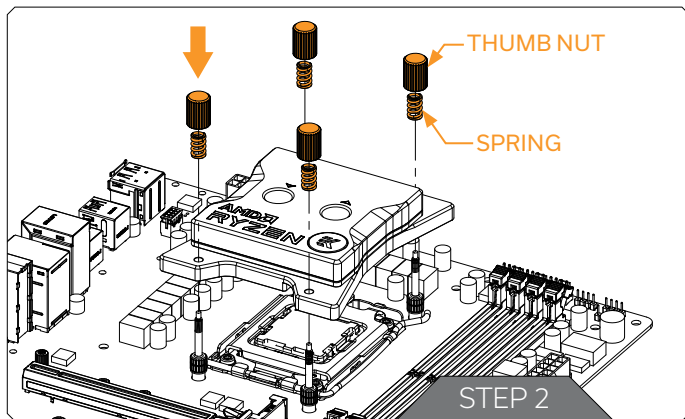

### STEP 2

Align the water block over the mounting screws on the motherboard.

Place a saved compression spring and thumb nut over each AM5 Mounting screw. Start fastening two thumb nuts at a time, preferably in a cross pattern, and do not tighten them fully until all of them are partially screwed in. Then - using your fingers only - screw in all four thumb nuts until you reach the end of the thread.

## CONNECTING THE D-RGB LED STRIP

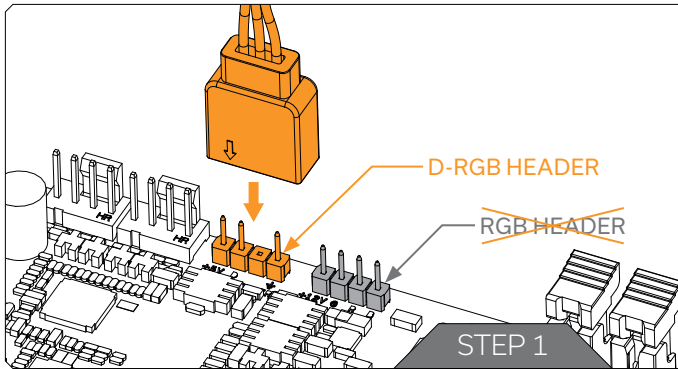

### STEP 1

Plug the 3-pin connector from the water block's D-RGB LED light to the DRGB HEADER on the motherboard. The LED will work if the pin layout on the header is as follows: **+5V, Digital, empty, Ground**.



Please ensure that the arrow indicated on the connector is plugged into the +5V line as indicated on your motherboard. If you put the LED Diode to the 12V RGB HEADER you can damage the LEDs. Failure to do so will damage your motherboard or LED strip.

## TESTING THE LOOP

To make sure the installation of EK components was successful, we recommend you perform a leak test for 24 hours. When your loop is complete and filled with coolant, connect the pump to a PSU outside of your system. Do not connect power to any of the other components. Turn on the PSU and let the pump run continuously. It is normal for the coolant level to drop during this process as air collects in the distribution plate. Inspect all parts of the loop, and in the eventuality that coolant leaks, fix the issue and repeat the testing process. Ensure that all hardware is dry before the system is powered on in order to prevent any damage.



## WARRANTY

Our products are warranted against defects of materials and quality for a period of 24 months, starting with the date of delivery to the end-user. During this period, products will be repaired or have parts replaced at our discretion, provided that 1) the product is returned to the agent from whom it was purchased; 2) the product has been purchased by the end-user and has not been used for commercial purposes; 3) the product has not been misused, handled carelessly, or used in a manner other than the way described in the instructions manual. This warranty does not confer rights other than those expressly set out above and does not cover any claims for consequential loss or damage. This warranty is offered as an extra benefit and does not affect your statutory rights as a consumer. This warranty is voided if the product comes in contact with aggressive UV additives or other improper liquids. EK water blocks are sealed with a warranty-voiding circular label, proving the water block has withstood a pressure leak test. Removing the label will void the leak-free guarantee, but not the guarantee on the product itself. Any other RMA issues can be reported to EK Customer Support at [www.ekwb.com/support](http://www.ekwb.com/support) for further analysis.

## SUPPORT AND SERVICE

In case you need assistance or wish to order spare parts or a new mounting mechanism, please contact:

**<https://www.ekwb.com/customer-support/>**

EKWB d.o.o.  
Pod lipami 18  
1218 Komenda  
Slovenia - EU

## SOCIAL MEDIA

 EKWaterBlocks

 @EKWaterBlocks

 ekwaterblocks

 EKWBofficial

 ekwaterblocks

