

# EK-Quantum Convection M.2 NVMe

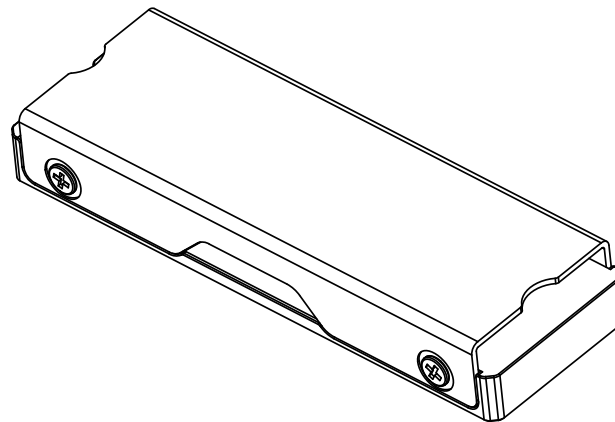
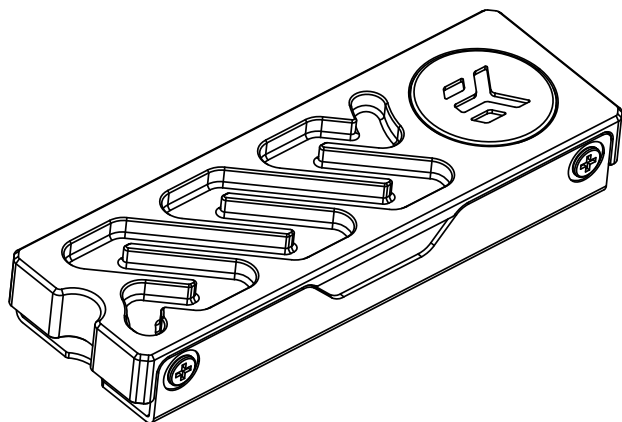

This product is intended for installation only by expert users. Please consult with a qualified technician for installation. Improper installation may result in damage to your equipment. EK Water Blocks assumes no liability whatsoever, expressed or implied, for the use of these products, nor their installation. The following instructions are subject to change without notice. Please visit our web site at [www.ekwb.com](http://www.ekwb.com) for updates. Before installation of this product please read important notice, disclosure and warranty conditions printed on the back of the box.

Before you start using this product, please follow these basic guidelines:

**Carefully read the manual before beginning the installation process.**

# TABLE OF CONTENTS

<b>BOX CONTENTS</b>	<b>4</b>
<b>REQUIRED TOOLS</b>	<b>4</b>
<b>M.2 NVMe HEATSINK DIMENSIONS</b>	<b>5</b>
<b>MAIN PARTS</b>	<b>6</b>
<b>PREPARING THE HEATSINK</b>	<b>6</b>
<b>SETTING THE HEATSINK CONFIGURATION</b>	<b>7</b>
<b>CUTTING AND PLACING THERMAL PADS</b>	<b>7</b>
<b>FIRST CONFIGURATION THERMAL PAD SELECTION AND PLACEMENT</b>	<b>8</b>
<b>SECOND CONFIGURATION THERMAL PAD SELECTION AND PLACEMENT</b>	<b>9</b>
<b>SUPPORT AND SERVICE</b>	<b>11</b>
<b>SOCIAL MEDIA</b>	<b>11</b>

## BOX CONTENTS

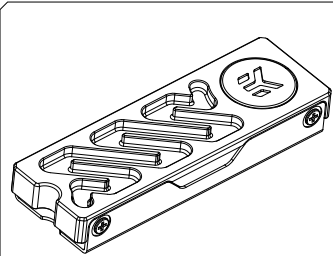

EK-Quantum Convection  
M.2 NVMe

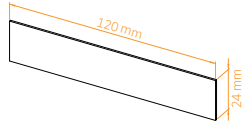

Thermal Pad G 1.0 mm (2 pcs)

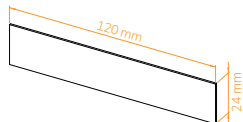

Thermal Pad G 0.5 mm (2 pcs)

## REQUIRED TOOLS

Phillips Head Screwdriver

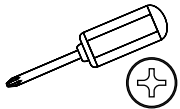

Scissors



## M.2 NVMe HEATSINK DIMENSIONS

Because of the flipping design, there are two configurations of the heatsinks dimension.

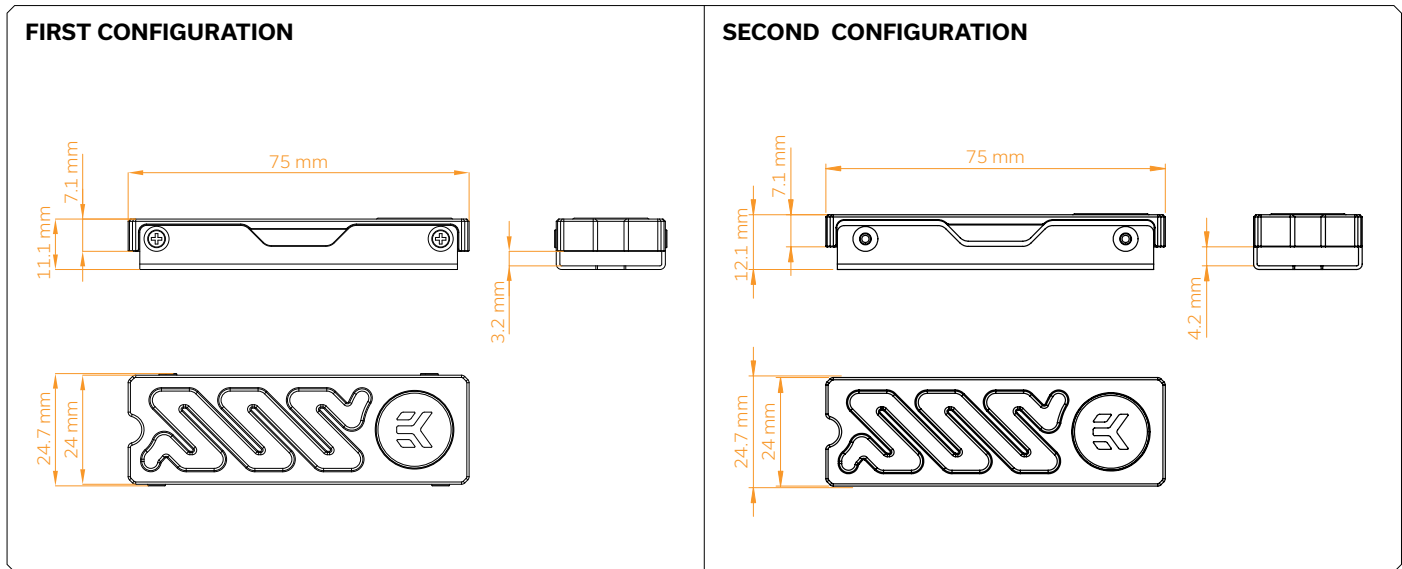

## MAIN PARTS

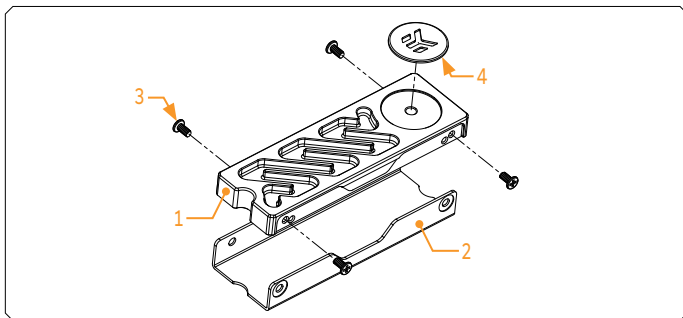

Position	EAN	Description	Quantity
1	104603	Aluminum Front Cover - Nickel	1
	104605	Aluminum Front Cover - Silver	
	104604	Aluminum Front Cover - Black	
	105057	Aluminum Front Cover - Gold	
2	104607	Aluminum Backplate - Black	1
3	104997	M2 x 4 Screw - Black	4
4	100663	EK Badge	1

## PREPARING THE HEATSINK

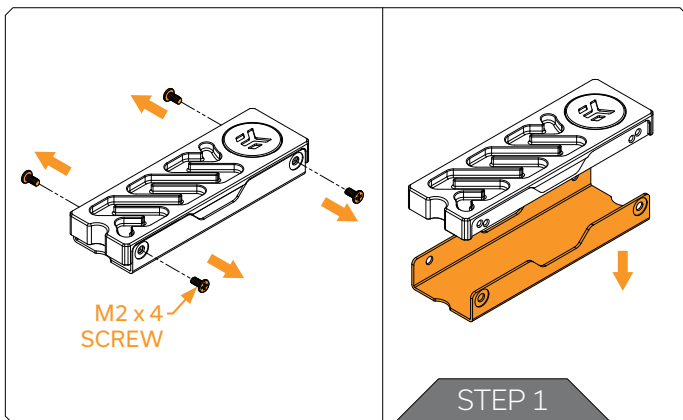

First, remove the four (4) M2 x 4 screws so the backplate of the heatsink can be removed.

Remove the backplate.

For this Step, you will need:

Phillips Head Screwdriver

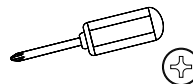

## SETTING THE HEATSINK CONFIGURATION

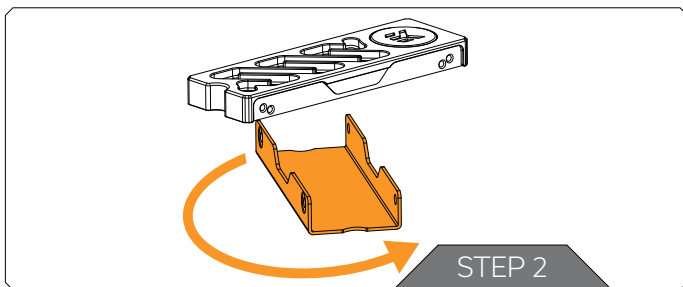

The Aluminum Cover has two alignments of holes. The first hole alignment is dedicated for installing the Single-Sided M.2 SSDs, which means all the storage and controller electronics are placed on one side of the drive PCB. The heatsink comes out of the box in the same configuration. The second hole alignment configuration provides additional clearance for Two-Sided M.2 SSDs, which have chips on both sides of the PCB. This configuration can be achieved by flipping the backplate and aligning the backplate with the second position of the threaded holes as shown in the picture below.

## CUTTING AND PLACING THERMAL PADS

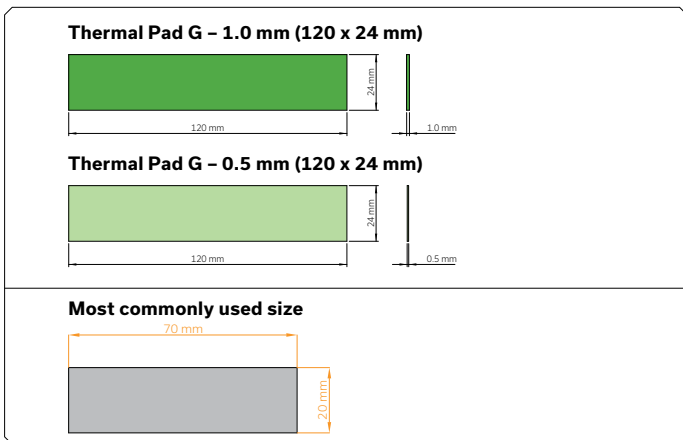

Your M.2 NVMe Heatsink came with more than an adequate amount of thermal pads.



**CAUTION:** You must remove the protective foil from both sides of the thermal pad before installation.

Thermal Pad G 1.0 mm - (120 x 24 mm) EAN: 3830046996770  
Thermal Pad G 0.5 mm - (120 x 24 mm) EAN: 3830046996763

EK recommends cutting the provided thermal pads to the size most optimal for M.2 NVMe drive coverage. The size shown below is most commonly used, but we recommend cutting it in size to cover all the storage and controller electronics on your M.2 NVMe SSD drive.

## FIRST CONFIGURATION THERMAL PAD SELECTION AND PLACEMENT

Picture for reference:  
Installing the Firecuda  
530 SSD - 1 TB.

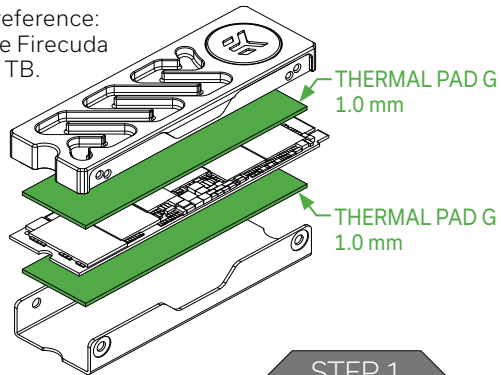

STEP 1

### STEP 1

The first hole alignment configuration is dedicated for M.2 drives with 500 GB storage and 1 TB storage. The picture below represents the thermal pad selection approved by EK testing on Firecuda 530 SSD drives. The use of thermal pad thickness may vary for each M.2 SSD drive manufacturer as we cannot guarantee the same height of chips on each. Check for proper thermal pad contact once the heatsink is assembled. EK provided you with two (2) thermal pads - 0.5 mm thickness and two (2) thermal pads - 1 mm thickness so you can easily choose between the most optimal thickness for your drive.

Picture for reference: Installing the Firecuda 530 SSD - 1 TB.

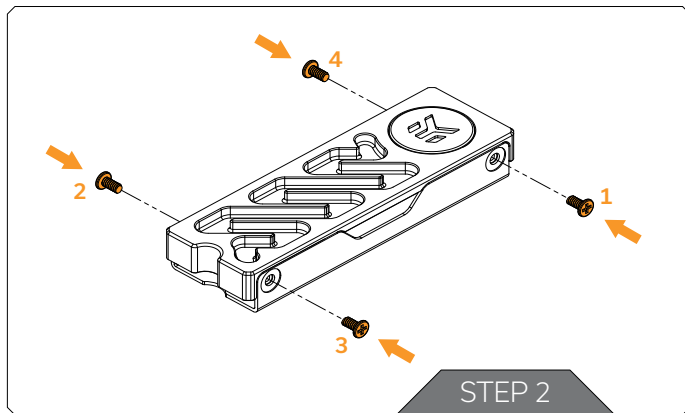

STEP 2

### STEP 2

Once installed together, secure the backplate onto the front cover with previously removed four (4) M2x4 screws. We recommend tightening them in order as shown in the picture.

Please pay attention to hole alignment on both sides of the heatsink!

For this step, you will need:

Phillips Head Screwdriver

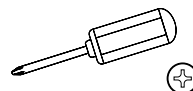



## SECOND CONFIGURATION THERMAL PAD SELECTION AND PLACEMENT

Picture for reference:  
Installing the Firecuda  
530 SSD - 2 TB.

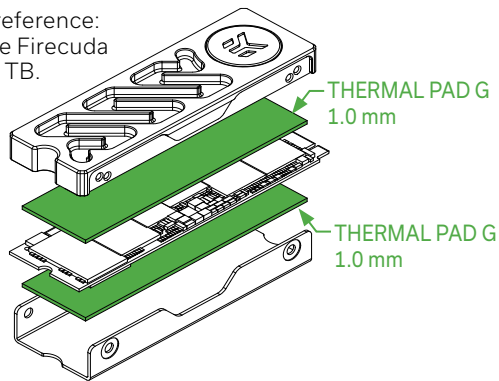

Picture for reference:  
Installing the Firecuda  
530 SSD - 4 TB.

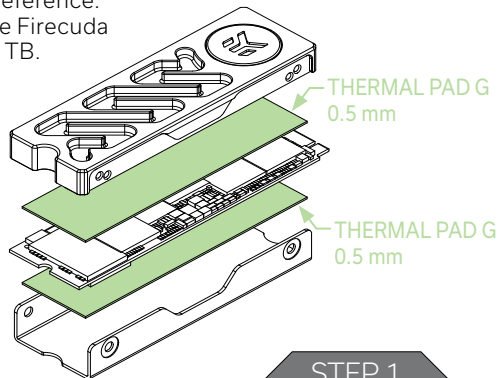

STEP 1

### STEP 1

The second hole alignment configuration is dedicated for M.2 drives with 2 TB storage and 4 TB storage. The picture below represents the thermal pad selection approved by EK testing on Firecuda 530 SSD drives. The use of thermal pad thickness may vary for each M.2 SSD drive manufacturer as we cannot guarantee the same height of chips on each. Check for proper thermal pad contact once the heatsink is assembled. EK provided you with two (2) thermal pads - 0.5 mm thickness and two (2) thermal pads - 1 mm thickness so you can easily choose between the most optimal thickness for your drive.

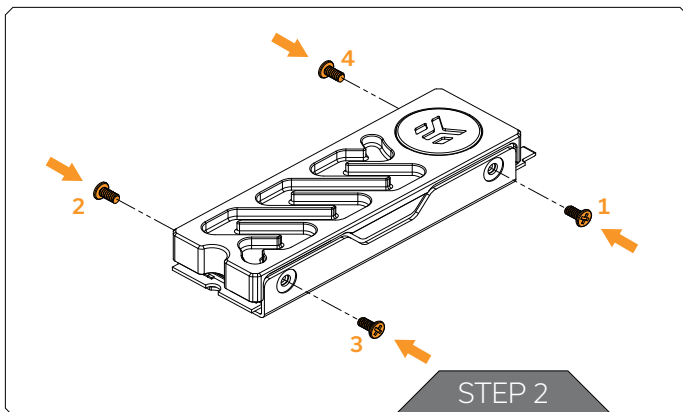

## STEP 2

Once installed together, secure the backplate onto the front cover with previously removed four (4) M2 x 4 screws. We recommend tightening them in order as shown in the picture.

Please pay attention to hole alignment on both sides of the heatsink!

For this step, you will need:

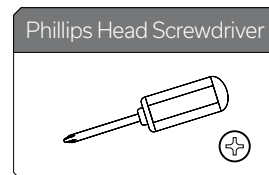

## SUPPORT AND SERVICE

In case you need assistance or wish to order spare parts or a new mounting mechanism, please contact:

**<https://www.ekwb.com/customer-support/>**

For spare parts orders, refer to the page with "MAIN PARTS" where you can find the EAN number of each part you might need.

Include the EAN number with quantity in your request.

Thermal pads are readily available in the EK shop

## SOCIAL MEDIA

 EKWaterBlocks

 @EKWaterBlocks

 ekwaterblocks

 EKWBofficial

 ekwaterblocks

