

# EK-Quantum Torsion A60

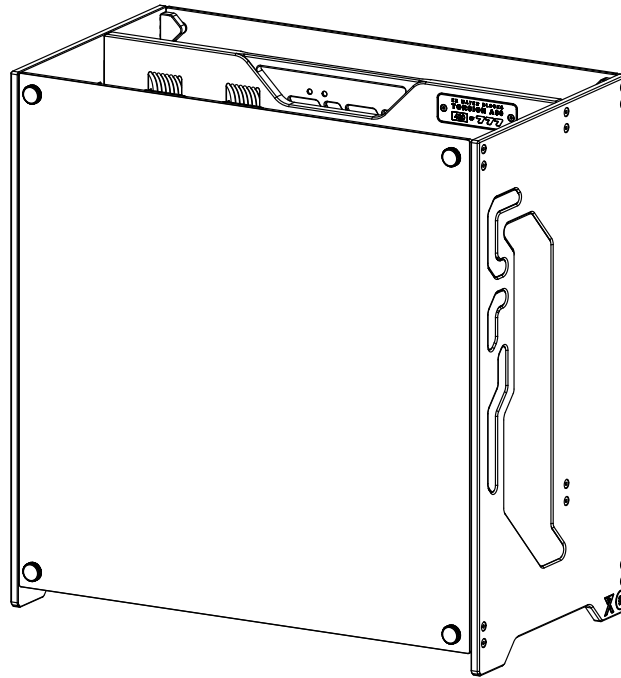

This product is intended for installation only by expert users. Please consult with a qualified technician for installation. Improper installation may result in damage to your equipment. EK Water Blocks assumes no liability whatsoever, expressed or implied, for the use of these products, or their installation. The following instructions are subject to change without notice. Please visit our website at [www.ekwb.com](http://www.ekwb.com) for updates. Before installation of this product, please read the important notice, disclosure, and warranty conditions.

Before you start using this product, please follow these basic guidelines:

**Carefully read the manual before beginning with the installation process.**

**The EK fittings require only a small amount of force to screw them firmly in place since the liquid seal is ensured by the rubber O-ring gaskets.**

**The use of corrosion-inhibiting coolants is always recommended for any liquid cooling system. EKWB recommends any of the EK- Cryofuel for worry-free usage.**

# TABLE OF CONTENTS

<b>MODELS</b>	<b>4</b>
<b>UNPACKING THE BOX</b>	<b>4</b>
<b>PC CHASSIS INFORMATION</b>	<b>4</b>
<b>BOX CONTENTS</b>	<b>5</b>
<b>DISTRIBUTION PLATE MAIN PARTS AND TECHNICAL SPECIFICATIONS</b>	<b>6</b>
BLACK EDITION	6
SILVER EDITION	7
<b>PREPARING THE PC CHASSIS</b>	<b>8</b>
<b>INSTALLING THE PC COMPONENTS</b>	<b>8</b>
INSTALLING THE POWER BUTTON (OPTIONAL)	8
INSTALLING THE RADIATORS AND FANS	10
INSTALLING THE CUSTOM POWER CABLES	13
INSTALLING THE MOTHERBOARD AND CPU WATER BLOCK	13
INSTALLING THE GPU WATER BLOCK	14
INSTALLING THE PSU	15
<b>DISTRIBUTION PLATE CONFIGURATION</b>	<b>16</b>
<b>INSTALLING THE FITTINGS AND TUBING</b>	<b>17</b>
<b>CONNECTING THE PUMP</b>	<b>17</b>
<b>TESTING THE LOOP</b>	<b>18</b>
<b>SUPPORT AND SERVICE</b>	<b>19</b>
<b>SOCIAL MEDIA</b>	<b>19</b>

## MODELS

- EK-Quantum Torsion A60 - Black Limited Edition
- EK-Quantum Torsion A60 - Silver Limited Edition

## UNPACKING THE BOX

Carefully open the outer and inner boxes. Remove the chassis from the box and carefully lift it on the flat surface. All the additional stickers, foam, and packaging materials must be removed before running up the computer. The computer is heavy and some of the components are fragile.

Visually inspect the components before further steps. If you notice any errors, please contact the customer support:  
<http://support.ekwb.com/>



The packing materials can be recycled. Please dispose of packaging in accordance with the environmental regulations.

## PC CHASSIS INFORMATION

EK-Quantum Torsion A60 - Limited Edition PC case is created especially for liquid-cooled builds. It is entirely built of CNC-milled aluminum, weighing around 22 kg. The EK-Quantum Torsion A60 is not just a case but a statement. Its machined channels for custom-sleeved cables and an integrated D5-powered distribution plate make it a true marvel for water-cooling enthusiasts. The case fits the mid-tower standard and fits up to three medium-thick EK-Quantum Surface P360 radiators. A tempered glass side panel, an integrated vertical GPU bracket, and support for ATX and E-ATX motherboards.

## BOX CONTENTS

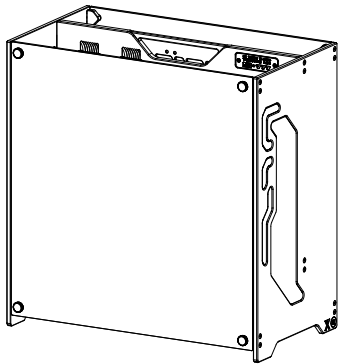

EK-Quantum Torsion A60



Screw M4x6 7991DIN (38 pcs)

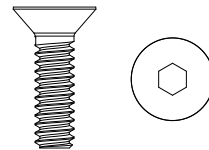

Screw UNC 6/32x1/2 (4 pcs)

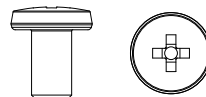

Screw UNC 6/32x1/4-Phillips  
Pan Screw (10 pcs)

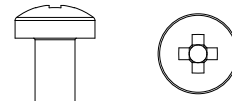

Screw M2.5x4 DIN7985 (2 pcs)

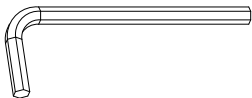

Allen Key 2 mm (1 pc)

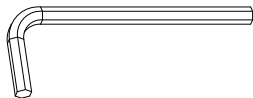

Allen Key 2.5 mm (1 pc)

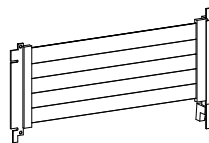

PCI-E Riser cable 4.0 (1 pc)



Torsion A60 - Power button (1 pc)

### Universal Mounting Mechanism

You may not need all the screws, mounting mechanism is universal!

- EAN; 105779 (Black edition)

- EAN;105778 (Silver edition)

## DISTRIBUTION PLATE MAIN PARTS AND TECHNICAL SPECIFICATIONS

### BLACK EDITION

- Dimensions (H x W x D): 415 mm x 251 mm x 92 mm (with the included pump and cover)
- Reservoir volume: ~450 ml
- D-RGB LED count: 14
- D-RGB cable length: 500 mm
- D-RGB connector standard 3-pin (+5V, Data, Blocked, Ground)

Position	EAN	Description	Quantity
1	101556	LED D-RGB strip 500/300 mm	1
2	5154	OR 52 x 3 NBR50	1
3	103314	Pump cover (Bl.elox)	1
4	100663	EK - Badge	1
5	103312	D5 Pump cover screw (Bl. Chrome)	4
6	3831109895269	EK-Quantum Torque Push-In Adapter	6
7	102639	Quantum Plug (Nickel)	4
8	104931	Distribution plate (Bottom)	1
9	104932	Distribution plate (Top)	1
10	104599	Mylar sticker	1
11	8312	Screw M4 x 16 DIN7991	74
12	OR SET	OR - Torsion Distribution Plate set	1
13	3831109837597	EK-D5 PUMP (Sata power)	1
14	104942	LED Cover (Bl.elox)	1
15	3831109834282	Plug Cover - Black	4

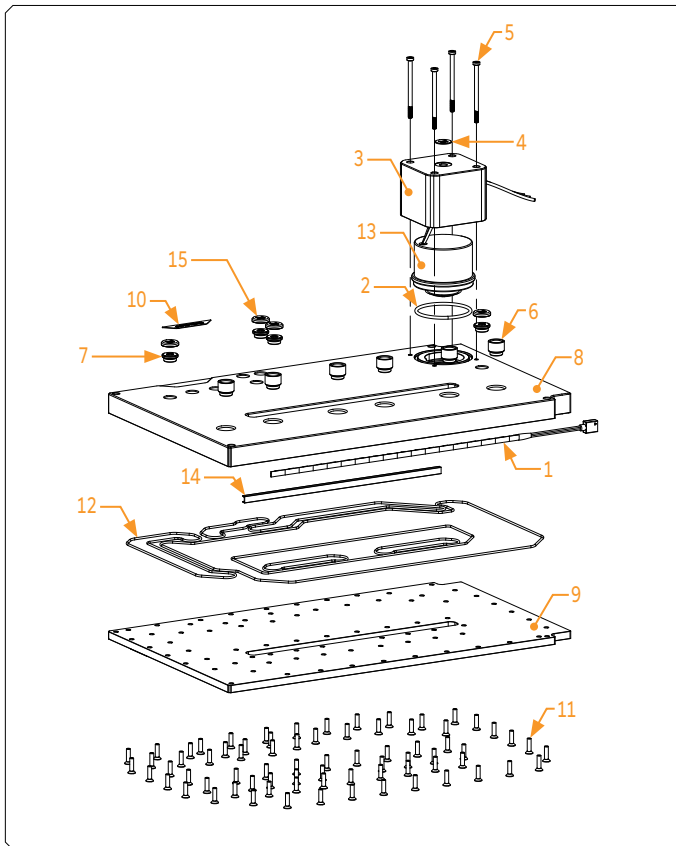

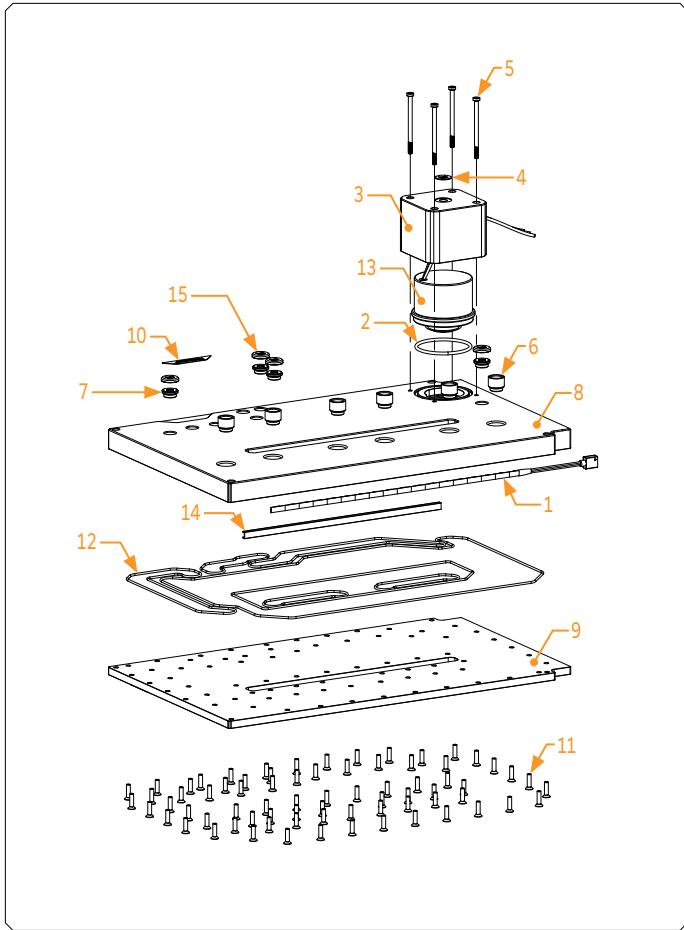

## SILVER EDITION

- Dimensions with the attached pump (H x W x D): 415 mm x 251 mm x 92 mm (with the included pump and cover)
- Reservoir volume: ~450 ml
- D-RGB LED count: 14
- D-RGB cable length: 500 mm
- D-RGB connector standard 3-pin (+5V, Data, Blocked, Ground)

Position	EAN	Description	Quantity
1	101556	LED D-RGB strip 500/300 mm	1
2	5154	OR 52 x 3 NBR50	1
3	103314	Pump cover (Nat. Elox)	1
4	100663	EK - Badge	1
5	103312	D5 Pump cover screw (Nickel)	4
6	3831109895269	EK-Quantum Torque Push-In Adapter	6
7	102639	Quantum Plug (Nickel)	4
8	104931	Distribution plate (Bottom)	1
9	104932	Distribution plate (Top)	1
10	104599	Mylar sticker	1
11	8312	Screw M4 x 16 DIN7991	74
12	OR SET	OR - Torsion Distribution Plate set	1
13	3831109837597	EK-D5 PUMP (Sata power)	1
14	104942	LED Cover (Nat. Elox)	1
15	3831109834282	Plug Cover - Black	4

## PREPARING THE PC CHASSIS

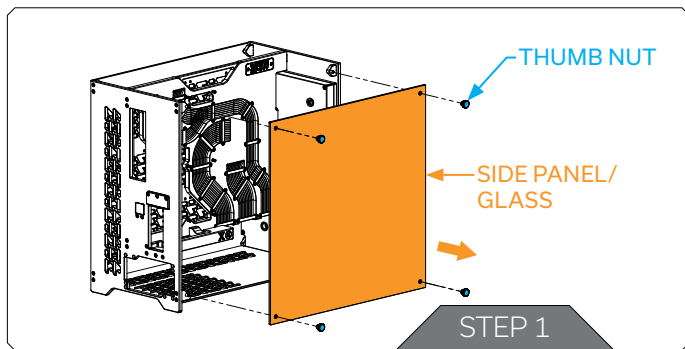

### STEP 1

Before installing the PC component, the side panel/glass must be removed. Unscrew four (4) thumb nuts (by hand) and carefully remove the glass from the chassis.

Store the glass and thumb nuts for later use. Make sure the side glass is stored in a suitable place.

## INSTALLING THE PC COMPONENTS

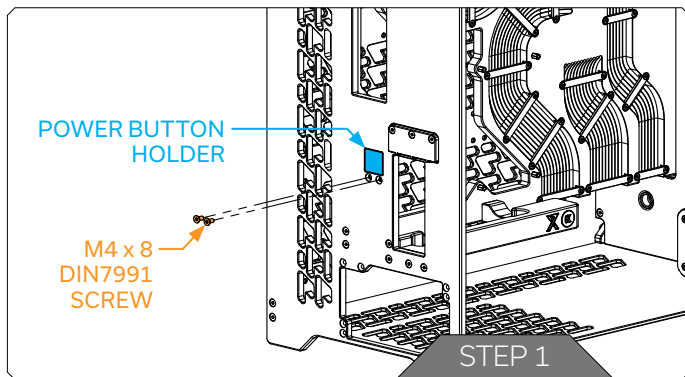

### INSTALLING THE POWER BUTTON (OPTIONAL)

#### STEP 1

Unscrew two (2) M4 x 8 DIN7991 Screws using Allen Key 2.5mm. Remove the Power button holder from the PC Chassis. Save the holder and screws for later use.

For this step, you will need:

Allen Key 2.5mm





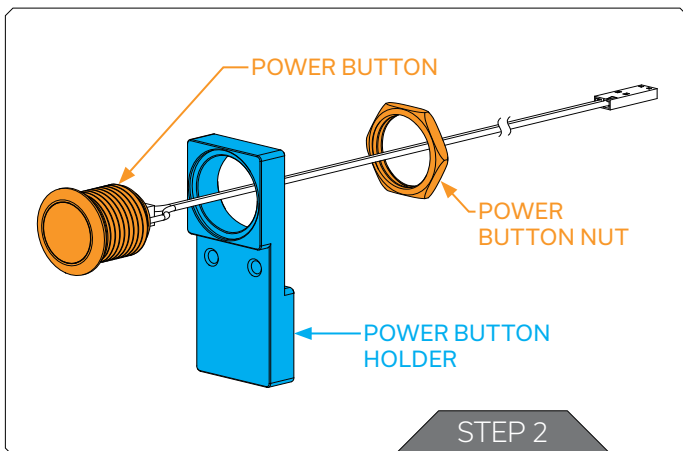

### STEP 2

Pick up the Power button from the provided mounting bag and insert it into the holder.

To secure the power button, use a nut.

Do not use excessive force.

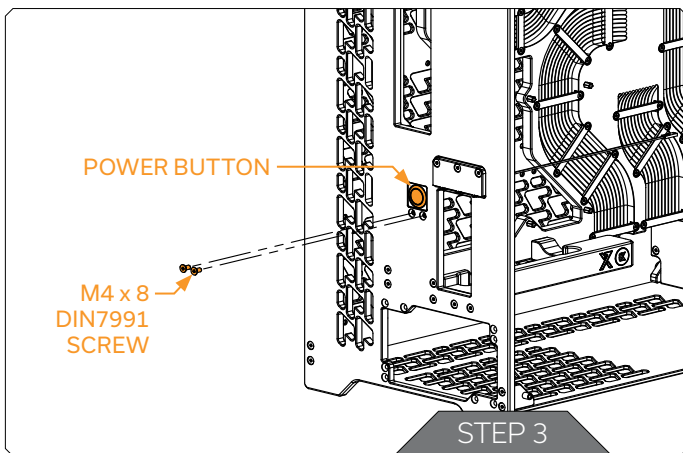

### STEP 3

Secure the Power button to the PC Chassis with two saved M4 x 8 DIN7991 Screws. Do not use excessive force.

After installing the motherboard into the PC Chassis, connect the Power button connector to the motherboard.

For this step, you will need:

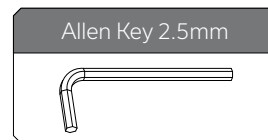

## INSTALLING THE RADIATORS AND FANS

### STEP 1

In order to install the radiators, the side panel must be removed. Unscrew four (4) thumb nuts by hand and remove the side panel from the PC Chassis.

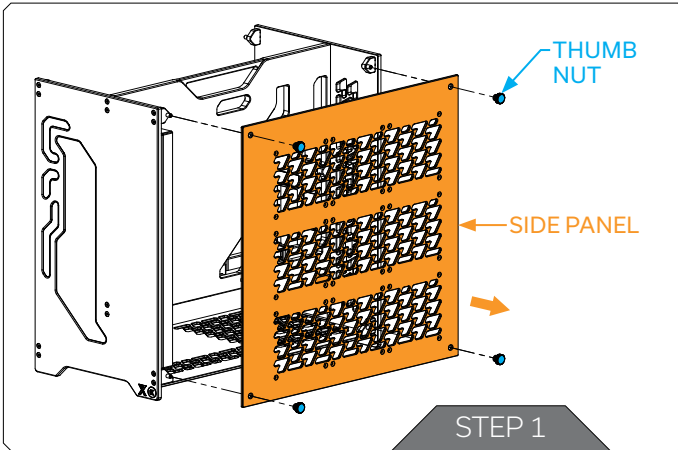

### STEP 2

Rotate the PC Chassis so that the distribution plate will be on the bottom. For easier radiator installation, EK recommends removing the bottom panel from the PC Chassis. Unscrew four (4) marked screws using Allen Key 2.5 mm and remove the bottom plate.

For this step, you will need:

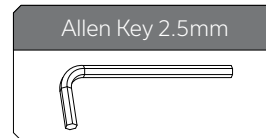

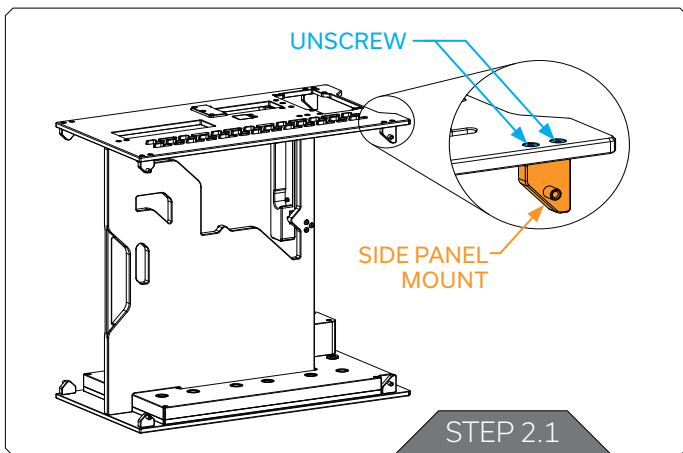

### STEP 2.1

If using the bottom radiator, we recommend removing the marked side panel mount. Unscrew two (2) marked screws using the Allen Key 2.5 mm. Save the parts for later use. After attaching the radiator to the PC Chassis, reattach the side panel mount.

For this step, you will need:

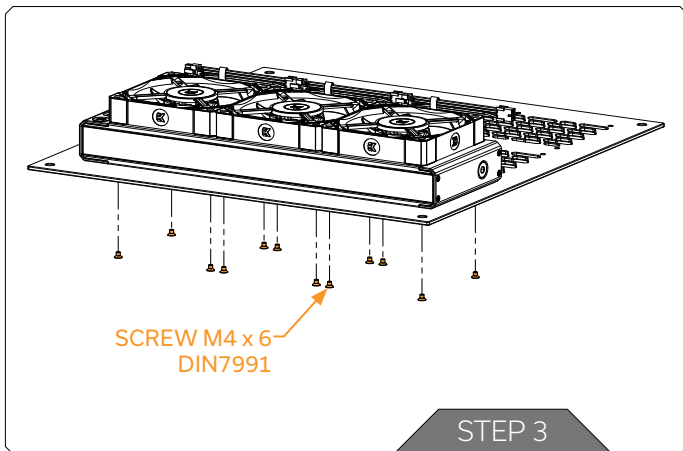
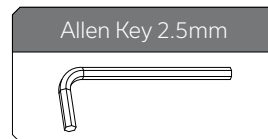

### STEP 3

Install the selected radiators with fans on the side panel. Secure the radiators with the provided mounting screws (M4 x 6 DIN7991). (The maximum radiator that will fit in the case is the P360M)

For this step, you will need:

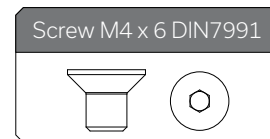
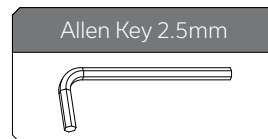

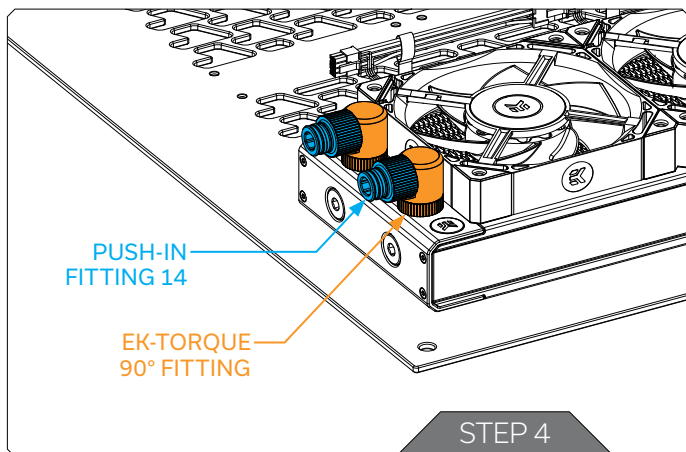

#### STEP 4

Install the Torque Fittings and Push-in adapters on the radiator.



For easier push-in adapters' installation, EK recommends lubricating the O-rings with a few drops of coolant or water.

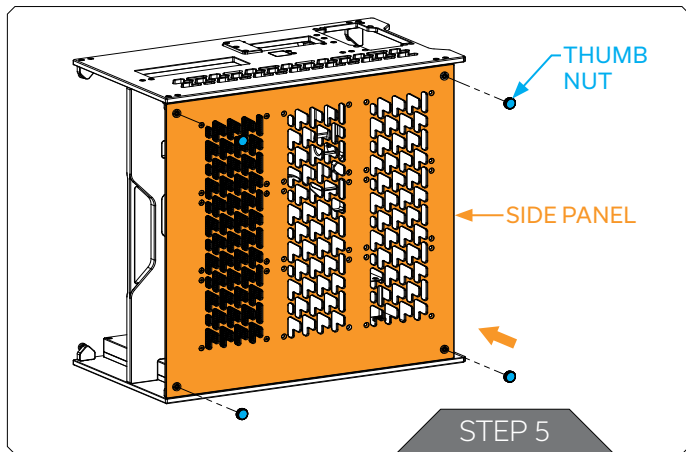

#### STEP 5

After installing the Radiators, reattach the side panel to the PC Chassis. Secure the side panel with saved thumb nuts. Make sure to place the Push-in fittings firmly in place.

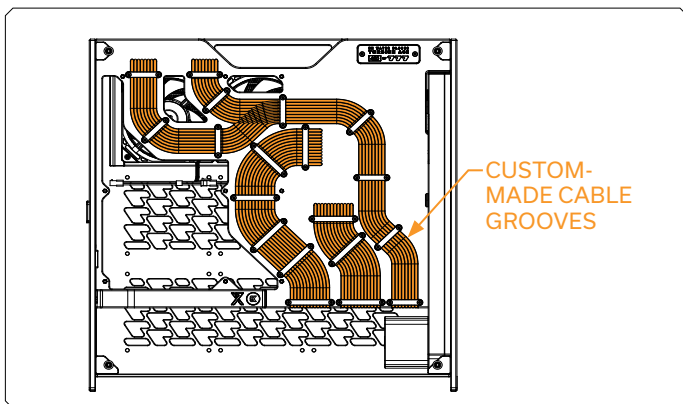

## INSTALLING THE CUSTOM POWER CABLES

EK-Quantum Torsion A60 allows you to achieve a clean, clutter-free build that shows off your cables. The motherboard tray holds grooves for all the important power cables:

- Twin 8-pin CPU EPS cables
- Up to three 8-pin PCIe power cables for the GPU or 12VHPWR cables
- ATX 24-pin motherboard cable

Each separate custom-sleeved cable fits into its own channel. For the GPU power cables, two types of cable holders are included based on the GPU connector being either standard 8-pin PCIe-based or 12VHPWR. The case comes with three holders for each of the GPU connectors.

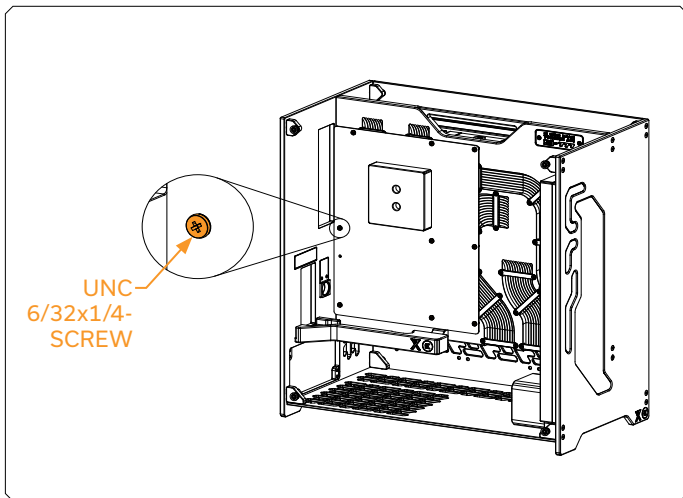

## INSTALLING THE MOTHERBOARD AND CPU WATER BLOCK

The EK-Quantum Torsion A60 supports ATX and E-ATX motherboards. The motherboard standoffs are pre-installed in the chassis.

**Before installing the motherboard in the computer case, attach the CPU water block to it.**

Secure the motherboard and CPU water block to the PC Chassis using the provided mounting screws (UNC 6/32x1/4-Phillips Pan Screw). Do not use excessive force!

For this step, you will need:

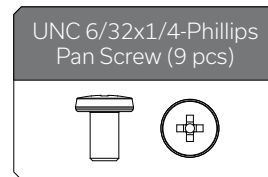
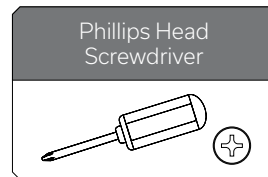

## INSTALLING THE GPU WATER BLOCK

### STEP 1

The GPU vertical bracket is already mounted in the PC Chassis. Before mounting the water-cooled GPU, it is necessary to install the PCI-E Riser cable 4.0 (provided with the PC Chassis). Attach it with two (2) mounting screws (M2.5 x 4 DIN7985). **Do not use excessive force!**

For this step, you will need:

Screw M2.5 x 4  
DIN7985 (2 pcs)

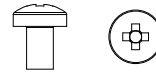

PCI-E Riser cable  
4.0

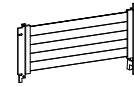

Phillips Head  
Screwdriver

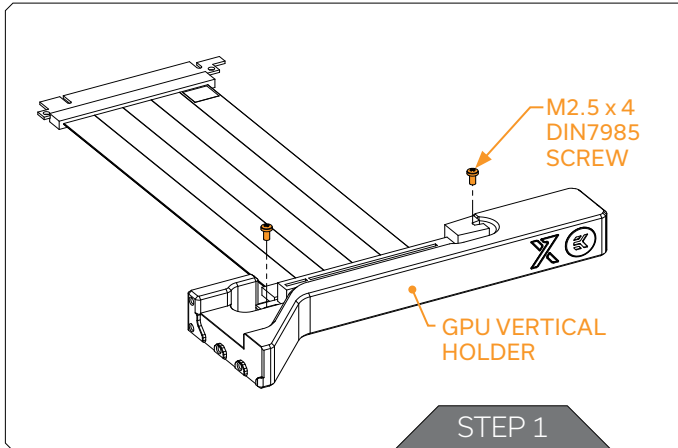
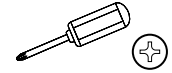

### STEP 2

The end side of the PCI-E Riser cable must be connected to the motherboard.

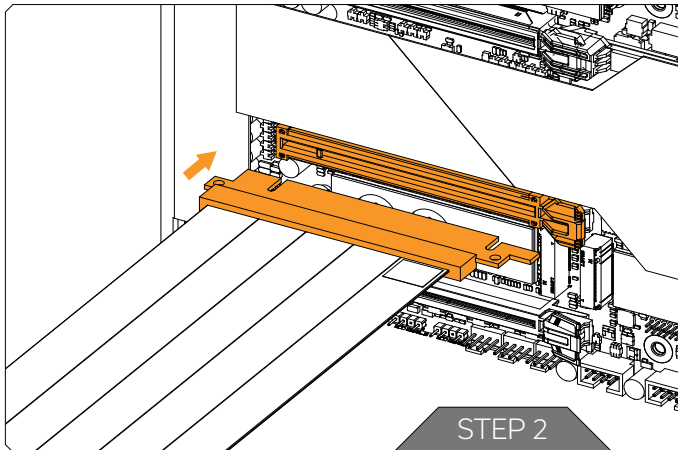

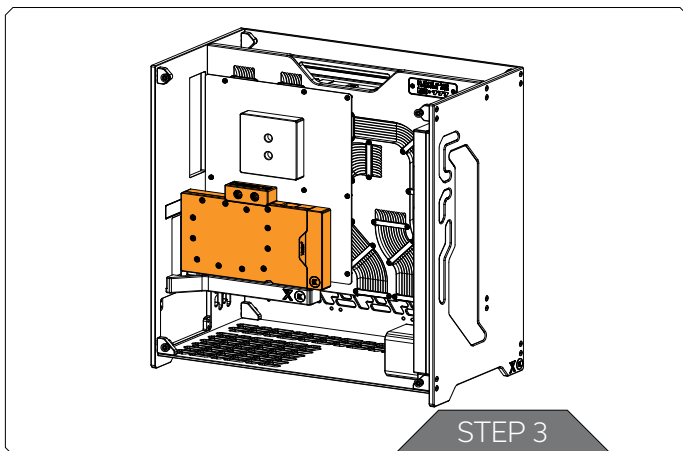

### STEP 3

Connect the water-cooled GPU to the PCI-E Riser cable.

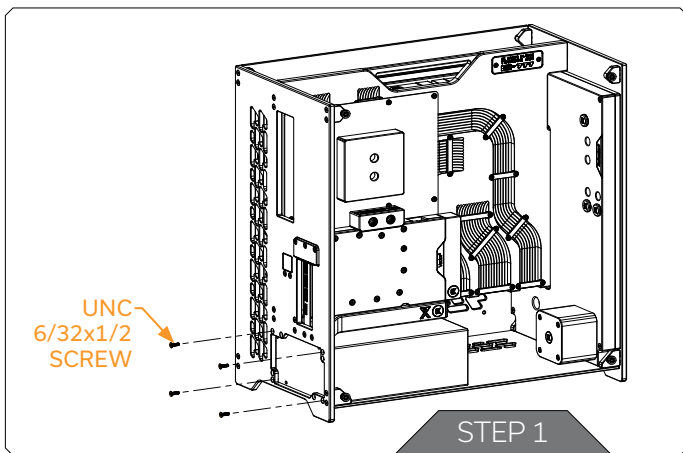

### INSTALLING THE PSU

Position the Power Supply into the PC Chassis and secure it with provided mounting screws (UNC 6/32x1/2).

**Do not use excessive force!**

For this step, you will need:

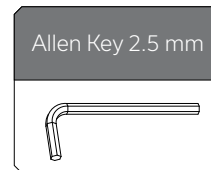
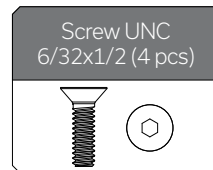

## DISTRIBUTION PLATE CONFIGURATION

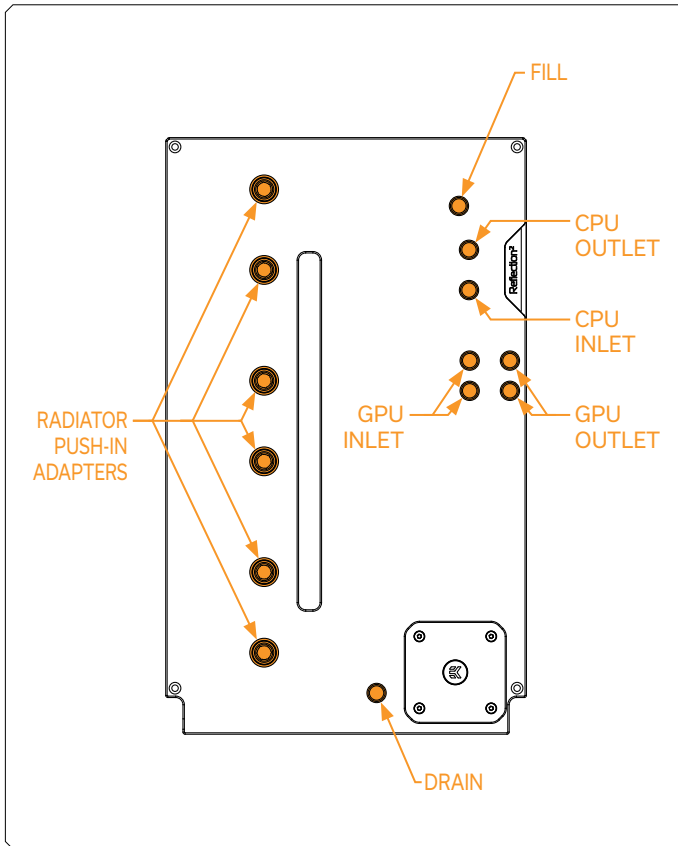

To complete your loop, all ports must be used as marked in the image.

All remaining unused ports (Fill and drain port) must be closed with supplied plugs.

Only one INLET and one OUTLET port for the GPU connection can be used, while all other INLET and OUTLET GPU ports must be closed with G1/4 plugs (enclosed in the package).

If one of the prescribed components will not be installed (ie. bottom radiator or GPU block) then one INLET and one OUTLET port must still be joined together in order for this distribution plate to function!



## INSTALLING THE FITTINGS AND TUBING



After the hardware parts are attached, the fittings and tubing have to be installed.

EK Recommends using the EK-Torque series fittings and EK-Rigid (hard) tubing. Make sure all the unused ports are closed with the provided EK-Plugs G1/4.

After completing the loop, it is mandatory to connect the Cables and "pressure" test the PC System before filling it. For the "pressure" test, EK recommends the use of an EK-Loop Flex Tester: <https://www.ekwb.com/shop/ek-loop-leak-tester-flex>

## CONNECTING THE PUMP

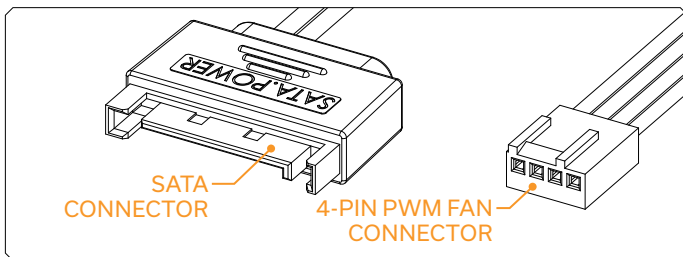

The EK-D5 PWM pump has two connectors.

- 1. SATA Connector:** It must be connected directly to your PSU at all times as it is used to power the pump.
- 2. 4-pin PWM fan:** It can be connected to your motherboard's CPU\_Fan or designated water pump header. It can also be connected to a controller. This cable is used to control and report the rotational speed of the pump. If it's not connected, the pump will run at maximum speed (100% PWM).

## TESTING THE LOOP

To make sure the installation of EK components was successful, we recommend you perform a leak test for 24 hours.

When your loop is complete and filled with coolant, connect the pump to a PSU outside of your system. Do not connect power to any of the other components. Turn on the PSU and let the pump run continuously. It is normal for the coolant level to drop during this process as air collects in the distribution plate.

Inspect all parts of the loop, and in the eventuality that the coolant leaks, fix the issue and repeat the testing process. Ensure that all hardware is dry before the system is powered on in order to prevent any damage.

## SUPPORT AND SERVICE

In case you need assistance or wish to order spare parts or a new mounting mechanism, please contact:

**<https://www.ekwb.com/customer-support/>**

For spare parts orders, refer to the page with "TECHNICAL SPECIFICATIONS AND PRODUCT PARTS" where you can find the EAN number of each part you might need.

Include the EAN number with quantity in your request. Mounting Mechanism EAN can be found under "BOX CONTENTS"

Thermal pads are readily available in the EK shop

## SOCIAL MEDIA

 EKWaterBlocks

 @EKWaterBlocks

 ekwaterblocks

 EKWBofficial

 ekwaterblocks

