

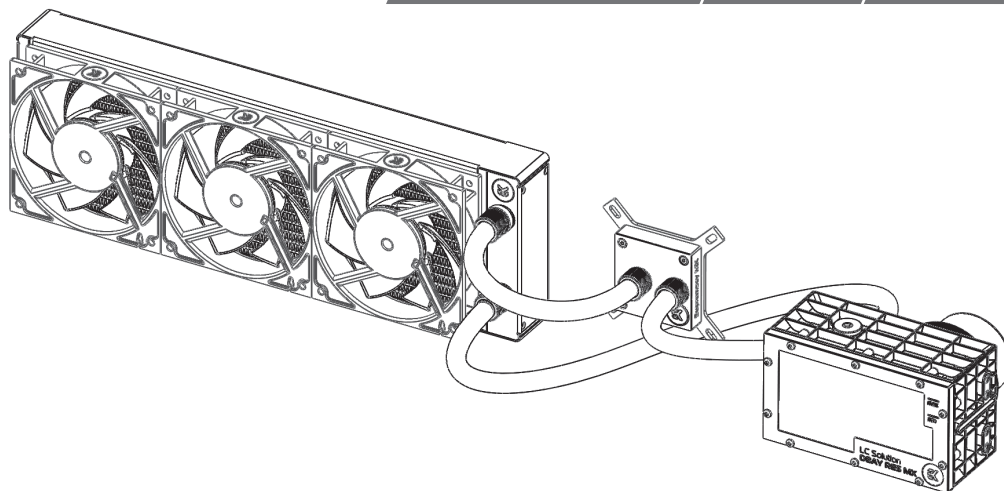

For EK-KIT G series units | 1st Revision, Oct 15th 2016

Starter Liquid Cooling Kit

**GAMING 240 280 360**



USER GUIDE



EK Water Blocks bears the name of its founder Edvard König, who started experimenting with liquid cooling in 1999. From the humble beginnings in the early years of the previous decade, the company grew steadily to become a global premium liquid cooling gear manufacturer. Today, EKWB offers a complete range of products for liquid cooling, from a renowned Supremacy line of CPU water blocks, wide range of in-house developed CoolStream radiators and Vardar High pressure fans to Predator all-in-one (AIO) Xpandable Liquid Cooling (XLC) solution, providing overclocking enthusiasts and PC builders with the best of what the market can offer. EK-KIT G cooling solution is the next step to bring extreme liquid cooling performance in the hands of dedicated gamers and PC enthusiasts around the world.

**Welcome to EK-World!**



## **Safety precautions**

1. Keep and store the product away from the reach of children.
2. Check the component list and condition of the product before installation.  
If there is any problem, contact the shop where you have purchased the product to get a replacement or refund.
3. EKWB d.o.o. is not responsible for any damages due to external causes, including but not limited to, improper use, problems with electrical power, accident, neglect, alteration, repair, improper installation and improper testing.
4. CPU and motherboard are subject to damage if the product is incorrectly installed.
5. This product is a CPU liquid cooling solution kit, comprising of individual original EKWB parts. Combining this liquid cooling unit with parts, other than EK Water Blocks products, may lead to warranty loss.
6. Product warranty period is 24 months.

# TABLE OF CONTENT

SCOPE OF DELIVERY .....	3	DRAINING OF THE LOOP .....	26
REQUIRED TOOLS .....	4	POSSIBILITIES OF EXPANDING THE SYSTEM .....	27
<b>QUICK INSTALLATION GUIDE</b>		MAINTENANCE .....	28
<b>RADIATOR SPACE CONSTRAINT REQUIREMENTS</b> .....	<b>5</b>	FREQUENTLY ASKED QUESTIONS .....	29
<b>DOZEN GOOD ADVICES FOR THE NEWCOMERS</b> .....	<b>6</b>	TROUBLESHOOTING .....	31
<b>LIQUID COOLING SYSTEM</b> .....	<b>6</b>	THE COOLER IS TOO LOUD .....	32
<b>GENERAL INFORMATION ON WATER BLOCK COMPATIBILITY</b> .....	<b>7</b>	<b>GENERAL LIQUID COOLING PARTS CLEANING GUIDE</b> .....	<b>32</b>
<b>INSTALLING THE WATER BLOCK</b> .....	<b>8</b>	PREVENTIVE STEPS .....	33
LGA-2011(-3) SOCKET MOTHERBOARDS .....	8	<b>SUPPORT AND SERVICE</b> .....	<b>34</b>
LGA-115X SOCKET MOTHERBOARDS .....	10	<b>SOCIAL MEDIA</b> .....	<b>34</b>
AMD® SOCKET MOTHERBOARDS .....	12		
<b>INSTALLING THE RADIATOR AND FANS</b> .....	<b>16</b>		
INSTALLING THE RADIATOR AND FANS .....	16		
INSTALLING THE RADIATOR AND FANS IN ONE GO .....	17		
<b>INSTALLING THE PUMP-RESERVOIR UNIT</b> .....	<b>18</b>		
<b>CONNECTING THE TUBING</b> .....	<b>19</b>		
<b>ELECTRICAL CONNECTIONS</b> .....	<b>21</b>		
CONNECTING THE PUMP-RESERVOIR UNIT .....	21		
CONNECTING THE FANS .....	22		
RECOMMENDED FILLING AND LEAK-TESTING PROCEDURE .....	23		
<b>FILLING THE SYSTEM FOR THE FIRST TIME</b> .....	<b>23</b>		

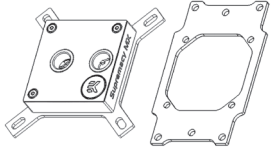
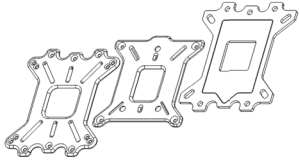
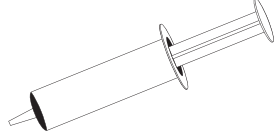
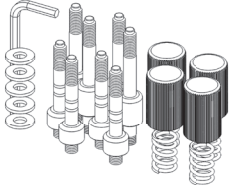
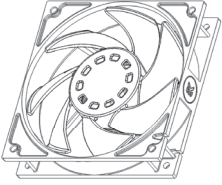
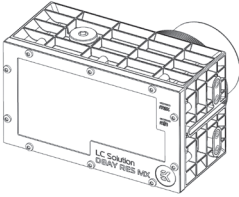
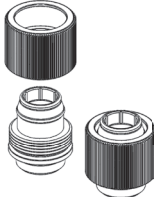
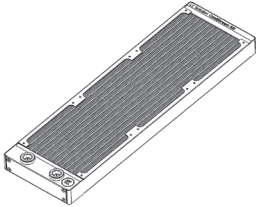
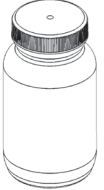
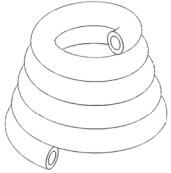
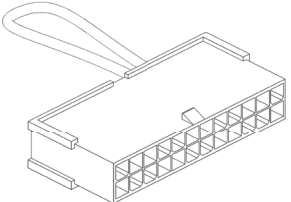
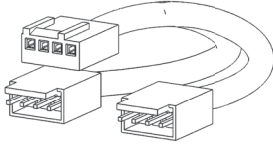

# SCOPE OF DELIVERY

<p>CPU water Block with AMD® mounting plate</p> 	<p>CPU Backplate mechanism</p> 	<p>Thermal grease</p> 	<p>CPU Mounting mechanism</p> 
<p>Fans</p> 	<p>Pump-Reservoir combo</p> 	<p>Compression fittings</p> 	<p>Radiator</p> 
<p>Coolant</p> 	<p>Tube</p> 	<p>ATX Bridging plug</p> 	<p>Fan cable Y-splitter</p> 

LED light

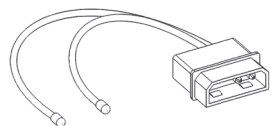

Installation manual

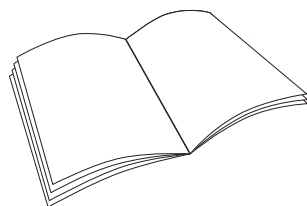

## REQUIRED TOOLS

Phillips-head screwdriver

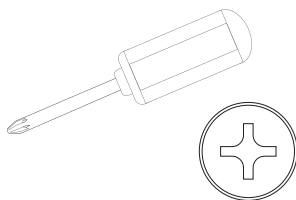

Mixing bottle

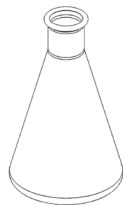

1L Bottle of distilled water



Pair of scissors

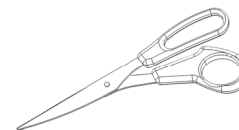

# RADIATOR SPACE CONSTRAINT REQUIREMENTS

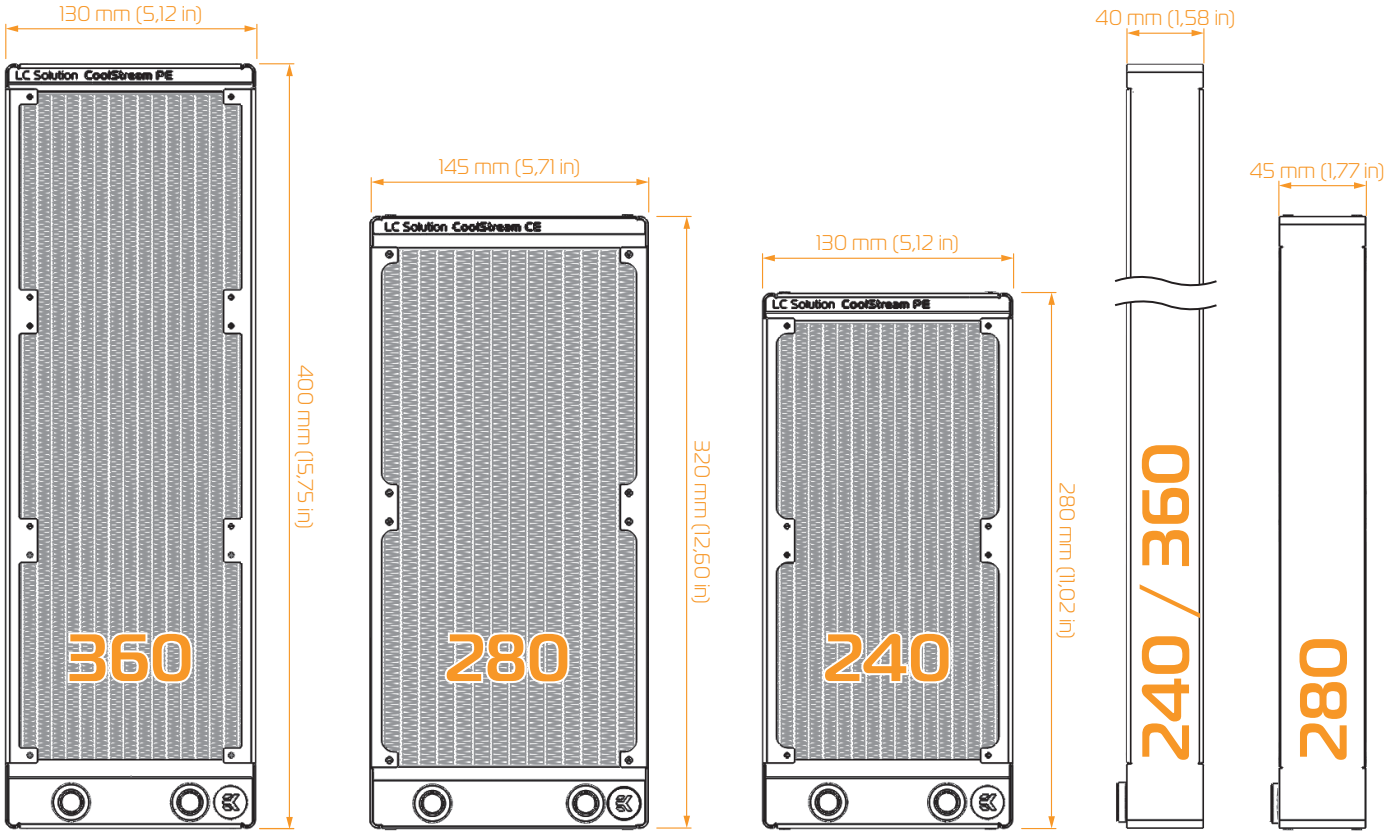

## DOZEN GOOD ADVICES FOR THE NEWCOMERS

1. In order to lower shipping costs we have decided to enclose only the coolant concentrate for liquid cooling. Therefore you need to provide 1 liter (1L) of distilled water. You can get it at every gas station or supermarket.
2. Never run this system on tap water and always use the enclosed cooling concentrate in correct ratio.
3. Never use alcohol, alcohol derivatives or alcohol based solvents in the system. Using alcohol might result in permanent damage to water cooling KIT components, especially acrylic parts of the system.
4. Reservoir must be positioned above the height level of the water pump which is crucial for the first start-up.
5. Generally, for optimal performance, the Reservoir must be positioned before the pump in the water loop.
6. Generally, for optimal performance, the CPU water block should be right after the Radiator in the water loop.
7. Generally, for optimal performance, the Pump should be positioned before the Radiator in the water loop.
8. It is best practice to do a proper leak test before using your computer.
9. If you spot any leaks, turn off the power immediately!
10. Optimize tubing length in order to prevent excessive bending and kinking of the tubing.
11. **Never let your pump run dry.** If this is happening for a prolonged period of time you may risk destroying water pump's bearing, rendering the pump useless.
12. You are encouraged to periodically clean the radiator assembly as it will collect dust over time. This is best done with soft wide tip brush and vacuum cleaner. See chapter 'General liquid cooling parts cleaning guide.'

## LIQUID COOLING SYSTEM

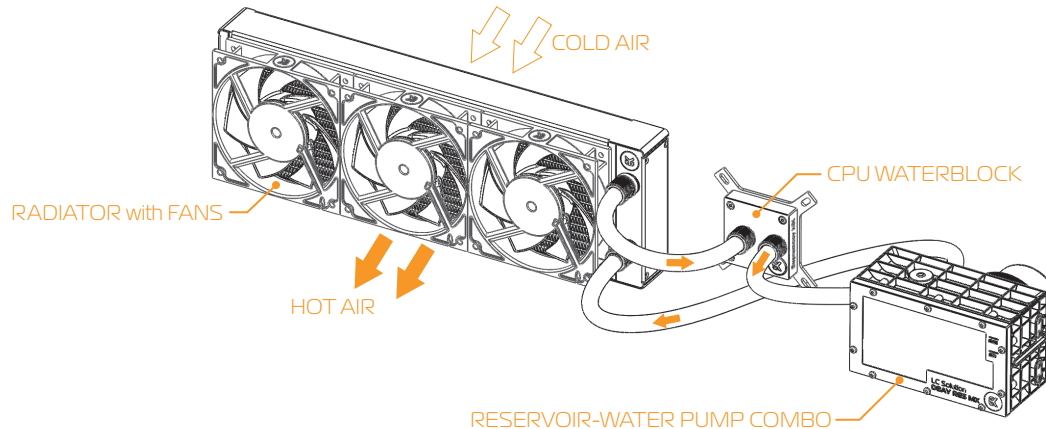

## GENERAL INFORMATION ON WATER BLOCK COMPATIBILITY

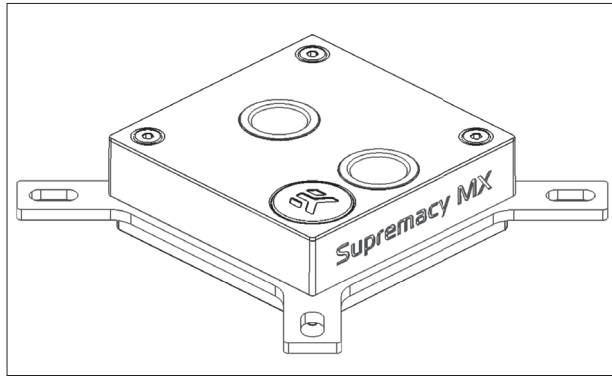

This CPU liquid cooling unit is pre-assembled for use with modern Intel desktop socket type motherboards. By default (out of the box) this water block supports the following CPU sockets:

- Intel® Socket LGA-775
- Intel® Socket LGA-115x
- Intel® Socket LGA-1366
- Intel® Socket LGA-2011(-3)



This product is also fully compatible with AMD® AMx/FMx sockets but requires a user to replace factory installed Intel mounting plate with AMD® one. The following sockets are then compatible:

- AMD® Socket AMx
- AMD® Socket FMx



Narrow server type LGA-2011 is not supported by default – a Mounting plate Supremacy LGA-2011 Narrow ILM (EAN: 3830046990600) is mandatory to install this water block on narrow server type LGA-2011 motherboards. Replacing the mounting plate requires disassembly of the water block.

## WHAT IS ENCLOSED

The following items are enclosed with each EK-Supremacy MX UNI water block:

- **EK-Supremacy MX UNI universal CPU water block**

- **PreciseMount MX UNI universal CPU mounting mechanism:**

- M4 threaded thumb screws (4 pcs)
- LGA-2011 M4 threaded mounting studs (4 pcs)
- Springs (4 pcs)
- M4 threaded thumb nuts (4 pcs)
- Washers (4 pcs)

- **AMD® mounting plate**

- **EK-Supremacy Backplate**

- Backplate rubber gasket
- Backplate for Intel LGA-1366 and AMD® socket motherboards
- Backplate for Intel LGA-115x socket motherboards
- Backplate for AMD® AM4 socket motherboards

- **EK-TIM Ectotherm (1g) thermal grease**

# INSTALLING THE WATER BLOCK

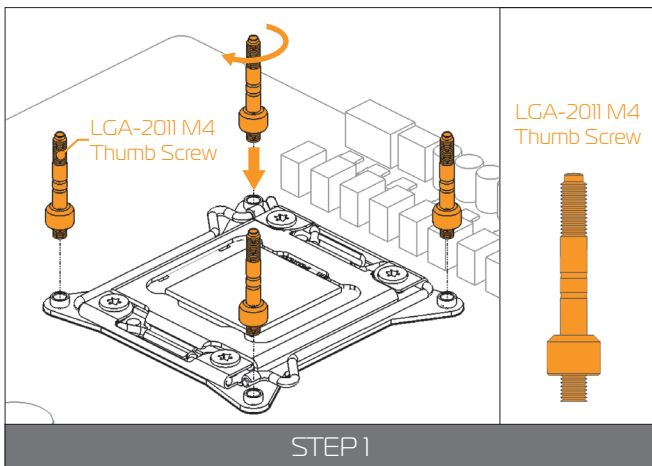

## LGA-2011(-3) SOCKET MOTHERBOARDS

### STEP 1

Prepare the foil bag with mounting mechanism, which is enclosed with the CPU water block delivery.

Install four (4) specific LGA-2011 M4 thumb screws into four M4 threaded stubs on the LGA-2011 socket integrated latch mechanism (ILM). The screws are to be installed using no tools (i.e. pliers).



It is recommended to remove the motherboard from the PC chassis before proceeding with installation of the CPU water block because of the space constraint limitations of various computer cases.

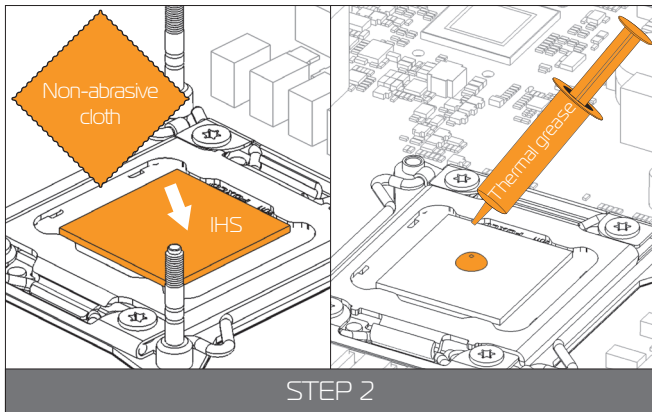

### STEP 2

**Cleaning the CPU:** Wipe the CPU's contact surface (by using non-abrasive cloth or Q-tip, as shown on sample photo).

**Applying thermal compound:** EK recommends blob or line method of applying the enclosed EK-TIM Ectotherm thermal compound to the CPU heat spreader (IHS) - see sample photo on right.



The quantity of about two rice grains is just about right. There is no need to cover the whole IHS. Applying too much thermal grease will have negative impact on the cooling performance!

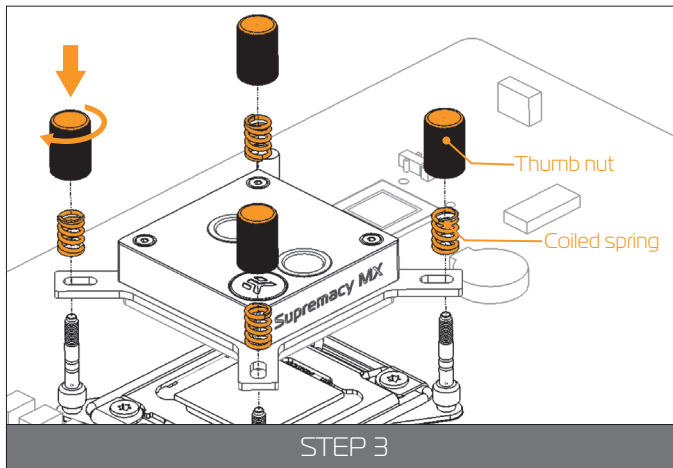

### STEP 3

Take the waterblock and remove the sticker on the copper head.

Align the water block over the mounting screws on the LGA-2011(-3) motherboard with pre-installed CPU.



Before proceeding with the installation it is mandatory to remove the protective foil from the backside of the water block.

Place an enclosed compression spring and thumb nut over each M4 thumb screw. Start fastening two thumb nuts at a time, preferably in cross pattern and do not tighten them fully until all of them are partially screwed in. Then - using your fingers only - screw in all four thumb nuts until you reach the end of the thread.

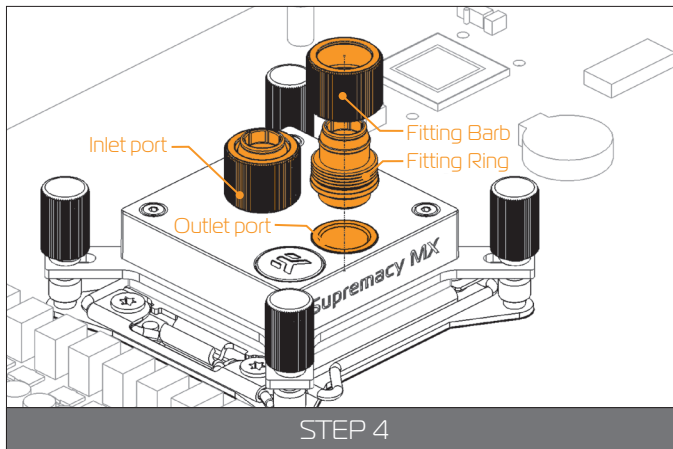

### STEP 4

Tighten the fitting bars in clockwise direction until the gasket underneath is compressed.

The installation of the CPU water block is now complete.



With EK-Supremacy MX series water blocks it is mandatory to use the port that is nearest to the center of the water block as INLET port. Mixing the ports may result in less than ideal thermal performance of the water block.

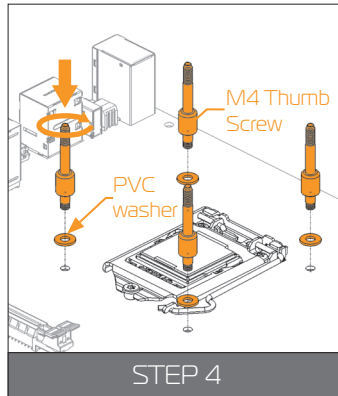
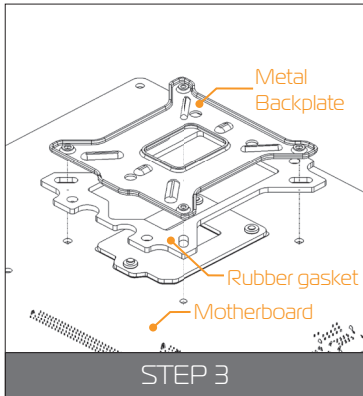
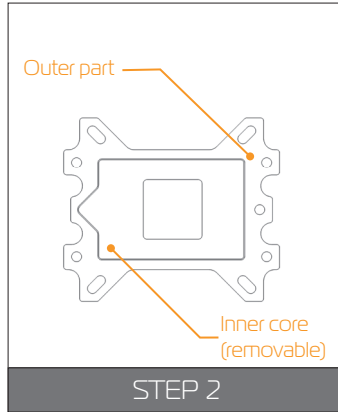
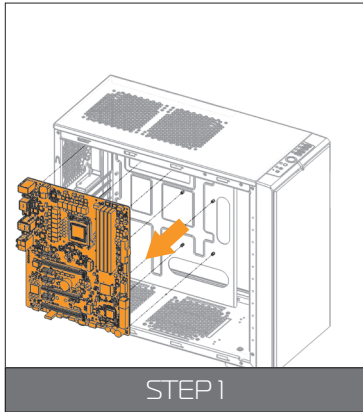

## LGA-115x SOCKET MOTHERBOARDS

### STEP 1

If already installed, please remove the motherboard from your computer and place it on an even surface with front facing down.

### STEP 2

#### Preparing backplate rubber gasket

The enclosed rubber gasket is essential part of the backplate and mounting system and must be used every time you install this water block on your motherboard.



The rubber gasket has a partially cut inner part which needs to be removed when installed on Intel LGA-115x motherboard. The rubber is held on four places and can be peeled away with hand.

### STEP 3

Install backplate rubber gasket and place metal backplate for Intel LGA-115x socket to the back of your motherboard RIBBED SIDE UP! (facing away from the motherboard) Align the holes on the motherboard with holes on rubber gasket and backplate.



Make sure to orientate the rubber gasket to fit past the CPU socket ILM backplate. On certain ITX form factor motherboards the rubber gasket may need to be trimmed using household scissors.

Carefully rotate motherboard assembly with front side facing up with one hand while holding the backplate and rubber in place with the other hand.

### STEP 4

Install four (4) M4 thumb screws onto your motherboard. It is mandatory to put 0.7mm plastic washer underneath each of the M4 thumb screws. Tighten the screws to the metal backplate until you reach the end of the thread. Using tools (such as pliers) is not recommended.



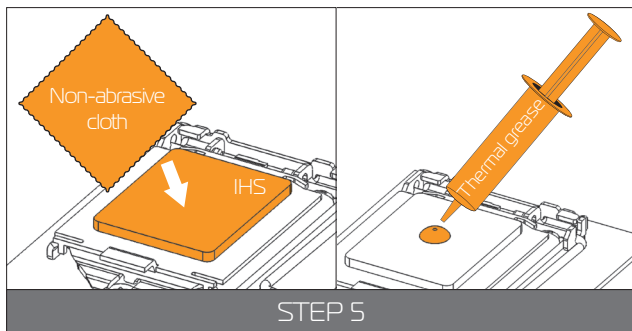

## STEP 5

**Cleaning the CPU:** Wipe the CPU's contact surface (by using non-abrasive cloth or Q-tip, as shown on sample photo).

**Applying thermal compound:** EK recommends blob or line method of applying the enclosed EK-TIM Ectotherm thermal compound to the CPU heat spreader (IHS) - see sample photo on right.



The quantity of about two rice grains is just about right. There is no need to cover the whole IHS. Applying too much thermal grease will have negative impact on the cooling performance!

## STEP 6

Align the water block over the mounting screws on the LGA-115x motherboard with pre-installed CPU.

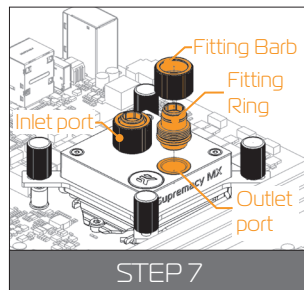
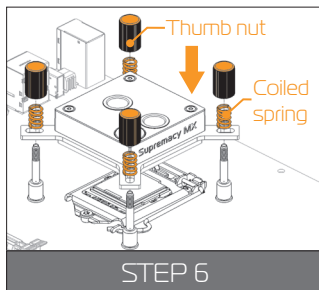

Before proceeding with the installation it is mandatory to remove the protective foil from the backside of the water block.

Place an enclosed coiled spring and thumb nut over each M4 thumb screw. Start fastening two thumb nuts at a time, preferably in cross pattern and do not tighten them fully until all of them are partially screwed in. Then – using your fingers only screw in all four thumb nuts until you reach the end of the thread.

## STEP 7



With EK-Supremacy MX series water blocks it is mandatory to use the port that is nearest to the center of the water block as INLET port. Mixing the ports may result in poor thermal performance of the water block.

Tighten the fitting barb in clockwise direction until the gasket underneath is compressed.

## STEP 8

Install the CPU water block along with the motherboard back into the computer chassis.

The installation of the CPU water block is now complete.

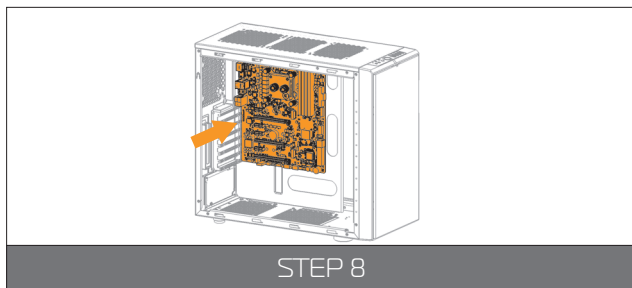

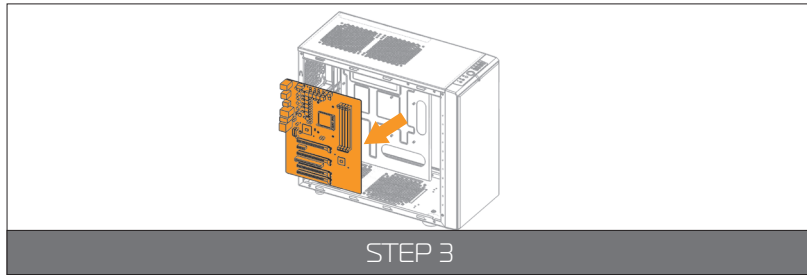
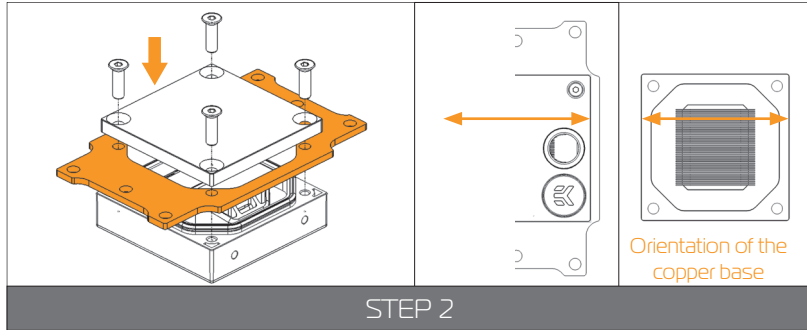
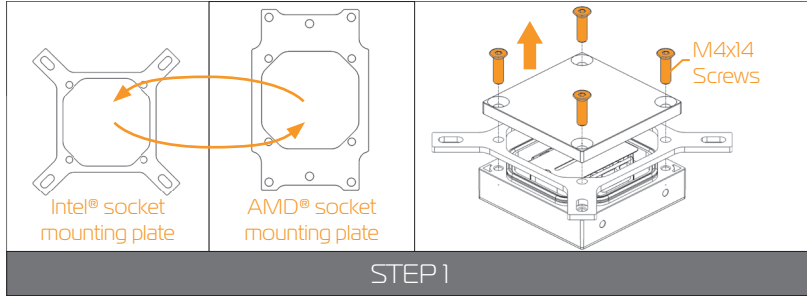

## AMD® SOCKET MOTHERBOARDS

### STEP 1

#### Replacing the mounting plate:

Place the water block on a even surface and remove the four M4x14 DIN 7991 screws attaching the copper base to the top using 2,5mm Allen key in counter-clockwise direction.

### STEP 2

Replace the Intel factory installed mounting plate with AMD® one. You will feel the mounting plate locking into the position when placed correctly on to the top.

Reseat the O-ring gasket (57x2,2mm) into the gap between the mounting plate and water block top.



Be careful that the orientation of the copper base is as shown on the picture

Reinstall the M4x14 screws and tighten them using 2,5mm Allen key to screw them in clockwise direction.

### STEP 3

If already installed, please remove the motherboard from your computer and place it on an even surface with front facing up.

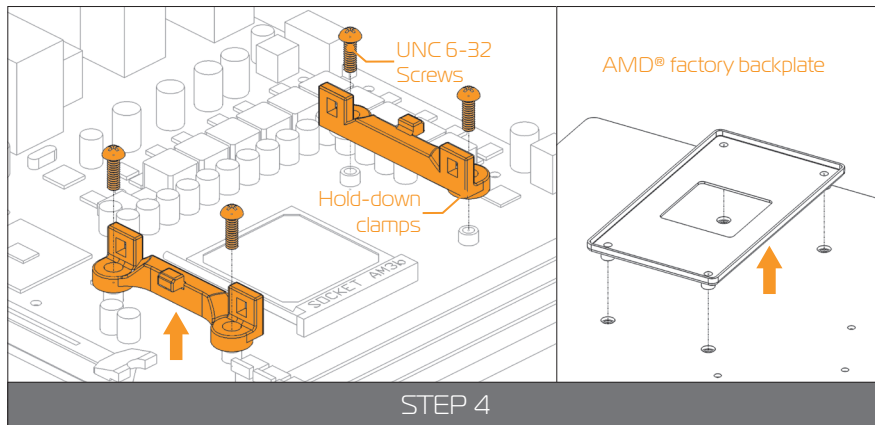

#### STEP 4

##### Removing of the original plastic hold-down clamps and the factory backplate:

Using Philips-head screwdriver remove the four UNC 6-32 screws securing the original plastic hold-down clamps around the socket as shown on the sketch. Remove the original AMD® backplate and the hold-down clamps and store them away. See sketch for further part identification.

#### STEP 5

##### Preparing backplate rubber gasket

The enclosed rubber gasket is essential part of the backplate and mounting system and must be used every time you install this water block on your motherboard.

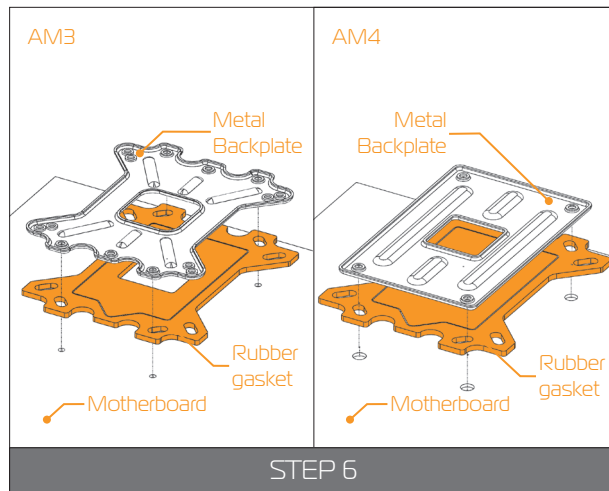
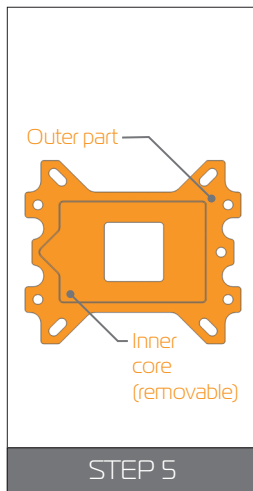

With AMD® Sockets you should use whole rubber backplate including the inner core.

#### STEP 6

Install backplate rubber gasket and place metal backplate for AMD® socket to the back of your motherboard **RIBBED SIDE UP!** (facing away from the motherboard) Align the holes on the motherboard with holes on rubber gasket and backplate.



Please use correct backplate, depending on your motherboard type (AM3 or AM4).

Carefully rotate motherboard assembly with front side facing up with one hand while holding the backplate and rubber in place with the other hand.

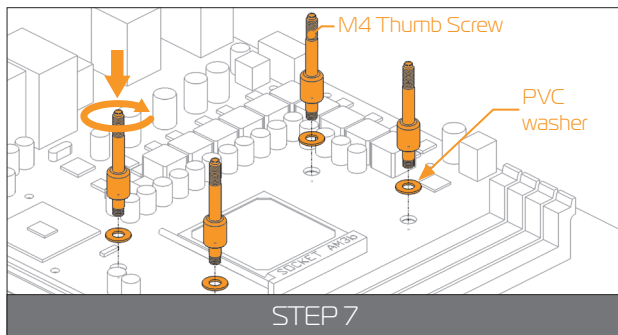

STEP 7

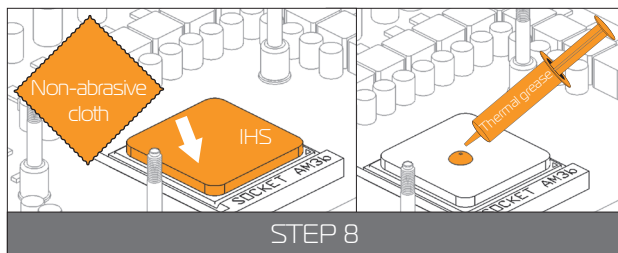

STEP 8

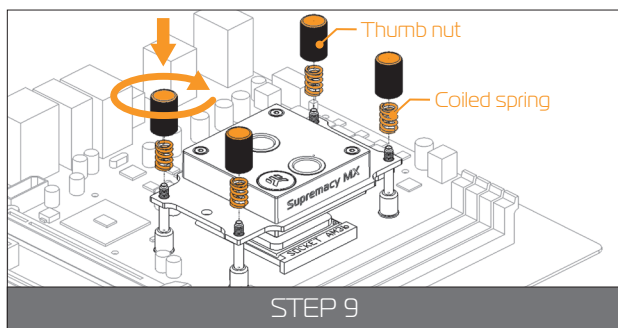

STEP 9

### STEP 7

Install four (4) M4 thumb screws onto your motherboard. It is mandatory to put 0.7mm plastic washer underneath each of the M4 thumb screws. Tighten the screws to the metal backplate until you reach the end of the thread. Using tools (such as pliers) is not recommended.

### STEP 8

**Cleaning the CPU:** Wipe the CPU's contact surface (by using non-abrasive cloth or Q-tip, as shown on sample photo).

**Applying thermal compound:** EK recommends blob or line method of applying the enclosed EK-TIM Ectotherm thermal compound to the CPU heat spreader (IHS) - see sample photo on right.



The quantity of about two rice grains is just about right. There is no need to cover the whole IHS. Applying too much thermal grease will have negative impact on the cooling performance!

### STEP 9

Align the water block over the mounting screws on the AMD socket motherboard with pre-installed CPU.



Before proceeding with the installation it is mandatory to remove the protective foil from the backside of the water block.

Place an enclosed coiled spring and thumb nut over each M4 thumb screw. Start fastening two thumb nuts at a time, preferably in cross pattern and do not tighten them fully until all of them are partially screwed in.

Then – using your fingers only screw in all four thumb nuts until you reach the end of the thread.

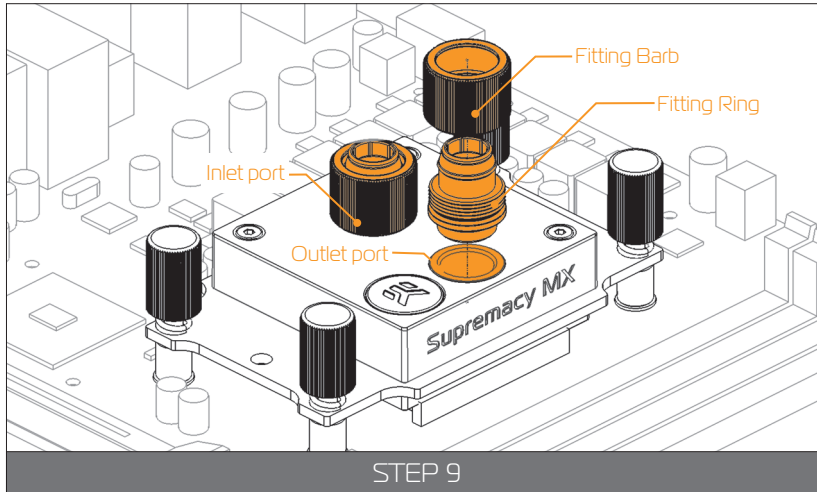

### STEP 9



With EK-Supremacy MX series water blocks it is mandatory to use the port that is nearest to the center of the water block as INLET port. Mixing the ports may result in poor thermal performance of the water block.

Tighten the fitting bars in clockwise direction until the gasket underneath is compressed.

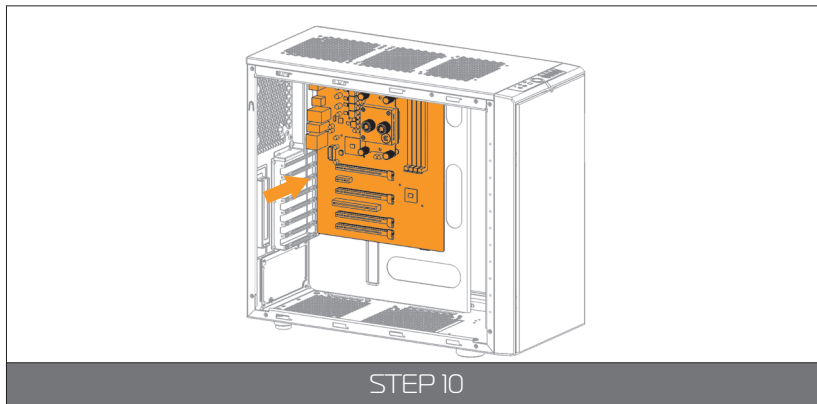

### STEP 10

Install the CPU water block along with the motherboard back into the computer chassis.

The installation of the CPU waterblock is now complete.

# INSTALLING THE RADIATOR AND FANS

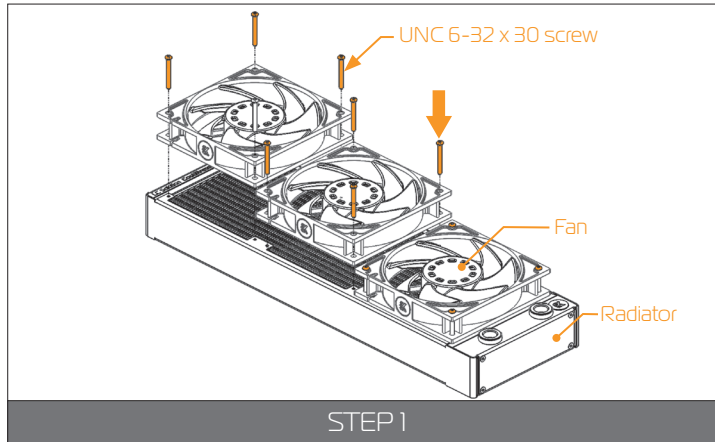

## OPTION #1: INSTALLING THE RADIATOR AND FANS

### STEP 1

Install the fans on the radiator.



Ideally, the radiator should either:

- A) **receive the coldest air possible** (by placing the radiator on the air inlet) or
- B) **serve as an overall hot air exhaust** (by placing the radiator on the exhaust).

The latter results in overall decrease of temperature throughout the entire computer chassis but also leads to slightly higher liquid temperatures. A reversed air flow is viable option but one should always strive to achieve unidirectional flow of air throughout the chassis.

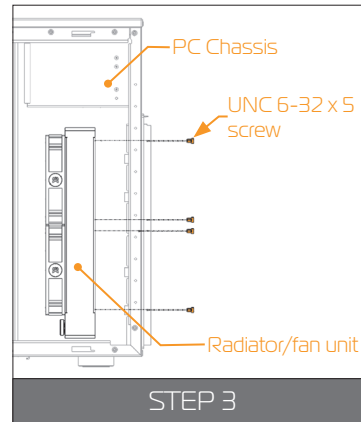
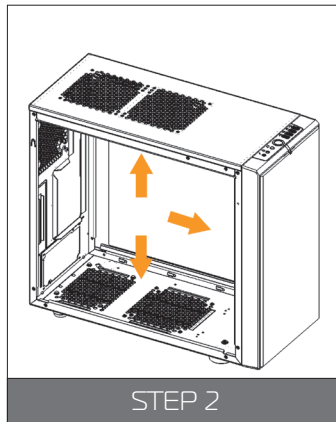

Take the four UNC 6-32x30mm screws for each fan and screw them in. Use enclosed Allen key to tighten the screws in clockwise direction.

### STEP 2

Prepare your suitably-sized PC chassis for installation of radiator unit. The position of the unit in the chassis depends on the size, fan mounting holes and the hardware you have installed. You must make sure that the unit fits into the chassis. Usually the chassis have standard fan mounting holes pre-drilled so you should look for holes with spacing of 105mm (A standard computer cooling 120mm fan) or 125mm (for 140mm cooling fan).

### STEP 3

Align the holes on the radiator with the ones on the PC chassis.

Take the four UNC 6-32x5mm screws for each fan and guide them through the holes on the chassis to screw them into the threaded holes on the radiator. Tighten them in clockwise direction using Allen key.

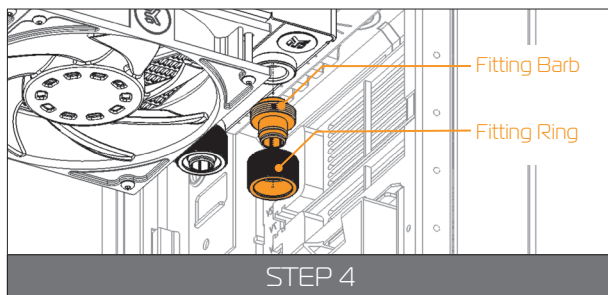

STEP 4

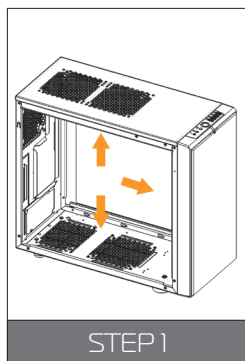

STEP 1

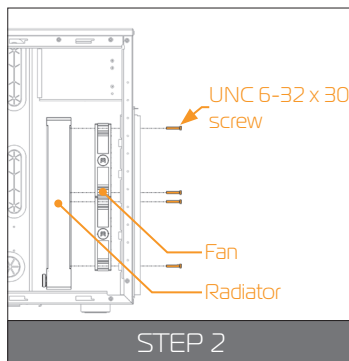

STEP 2

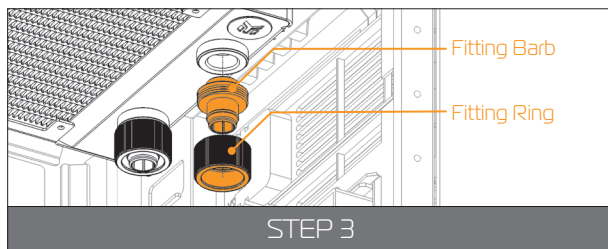

STEP 3

#### STEP 4

Install the compression fitting on both G1/4 extender openings on the radiator. Tighten the fitting bars in clockwise direction until the gasket underneath is compressed.

The installation of the radiator and radiator cooling fans is now complete.

## OPTION #2: INSTALLING THE RADIATOR AND FANS IN ONE GO

#### STEP 1

Prepare your suitably-sized PC chassis for installation of radiator unit. The position of the unit in the chassis depends on the size, fan mounting holes and the hardware you have installed. You must make sure that the unit fits into the chassis. Usually the chassis have standard fan mounting holes pre-drilled so you should look for holes with spacing of 105mm (A standard computer cooling 120mm fan) or 125mm (for 140mm cooling fan).

#### STEP 2

Align the holes on the fans and the radiator with the ones on the PC chassis.



Ideally, the radiator should either:

- A) **receive the coldest air possible** (by placing the radiator on the air inlet) or
- B) **serve as an overall hot air exhaust** (by placing the radiator on the exhaust).

The latter results in overall decrease of temperature throughout the entire computer chassis but also leads to slightly higher liquid temperatures. A reversed air flow is viable option but one should always strive to achieve unidirectional flow of air throughout the chassis.

Take the four UNC 6-32x30mm screws for each fan and guide them through the holes on the chassis and fans to screw them into the threaded holes on the radiator. Tighten them in clockwise direction using enclosed Allen key.

#### STEP 3

Install the compression fitting on both G1/4 extender openings on the radiator. Tighten the fitting bars in clockwise direction until the gasket underneath is compressed.

The installation of the radiator and radiator cooling fans is now complete.

# INSTALLING THE PUMP-RESERVOIR UNIT

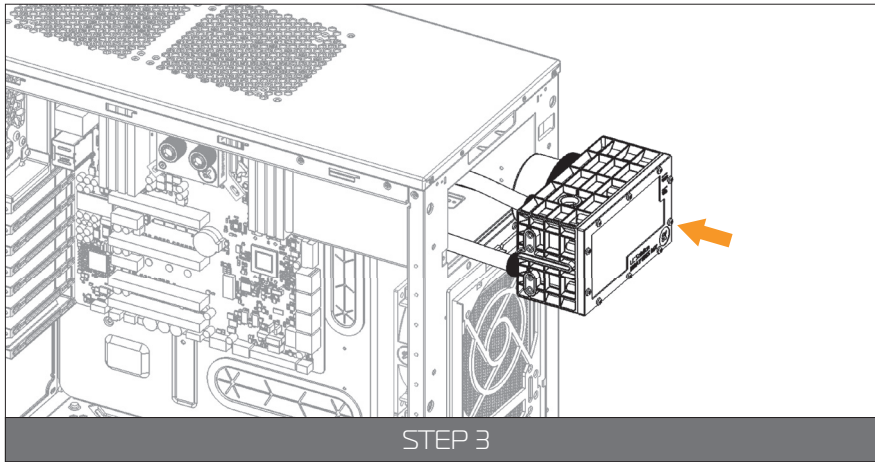
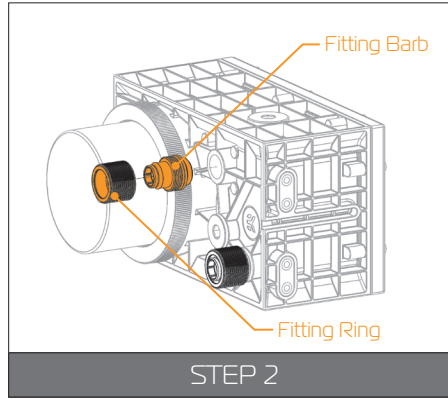
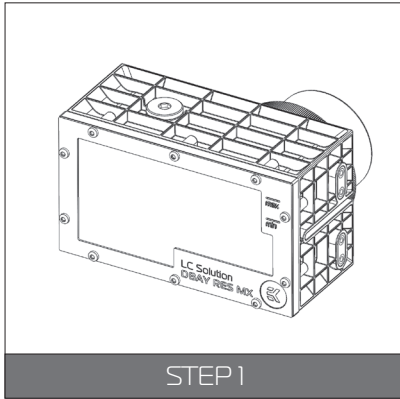

## STEP 1

The KIT comes with combined pump and reservoir unit with preinstalled vibration dampers.

## STEP 2



In order to simplify the installation process it is highly recommended to install compression fittings and tubing prior to installing pump-reservoir unit into the chassis. Proceed to Page 19, chapter CONNECTING THE TUBING. It is recommended to do so before continuing to STEP 3.

Install the compression fittings on both G1/4 threaded ports on the pump-reservoir as shown on the picture. Tighten the fitting barb using enclosed Allen Key 8mm until the sealing gasket ring is sufficiently compressed. Do not overtighten!

## STEP 3

This reservoir occupies two (2) 5.25" drive bay expansion slots in your computer chassis. Free two slots in case they are already occupied with other computer components such as optical or hard disk drives. Place the reservoir in your 5.25" drive bay, with the front plate facing outwards.



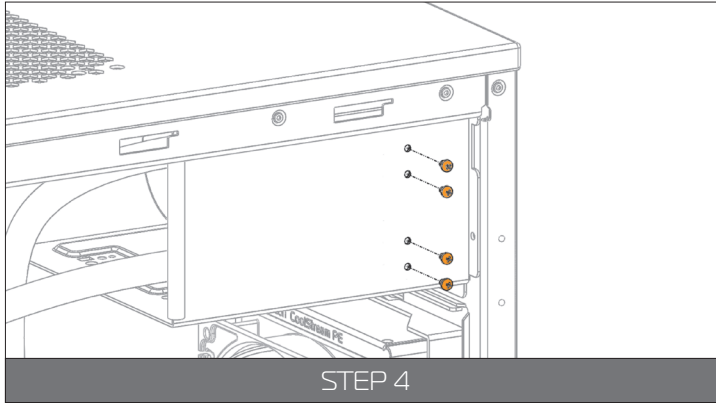

#### STEP 4

Using Philips head screwdriver secure the reservoir to the drive bay using the enclosed eight (8) M3x4 DIN 7985 screws – four from each side.

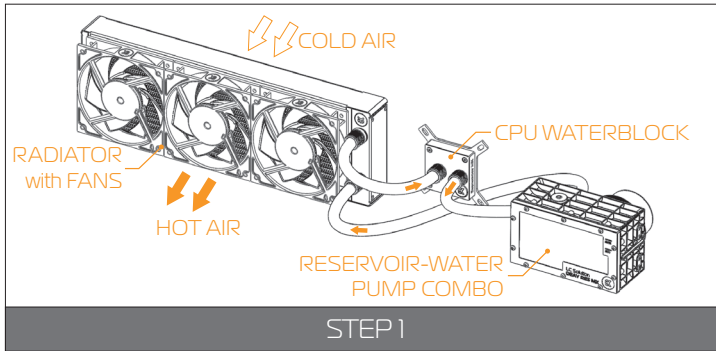

## CONNECTING THE TUBING



If you are expanding your loop with additional liquid cooling components please proceed to Page 27, chapter POSSIBILITIES OF EXPANDING THE SYSTEM.

#### STEP 1

In order to successfully route the tubing it is recommended that you check the water cooling scheme on the picture.

It is best that the water block receives the coldest fluid as possible, therefore you should connect the radiator's outlet port with the water block's inlet port. This is best practice but it is not mandatory.

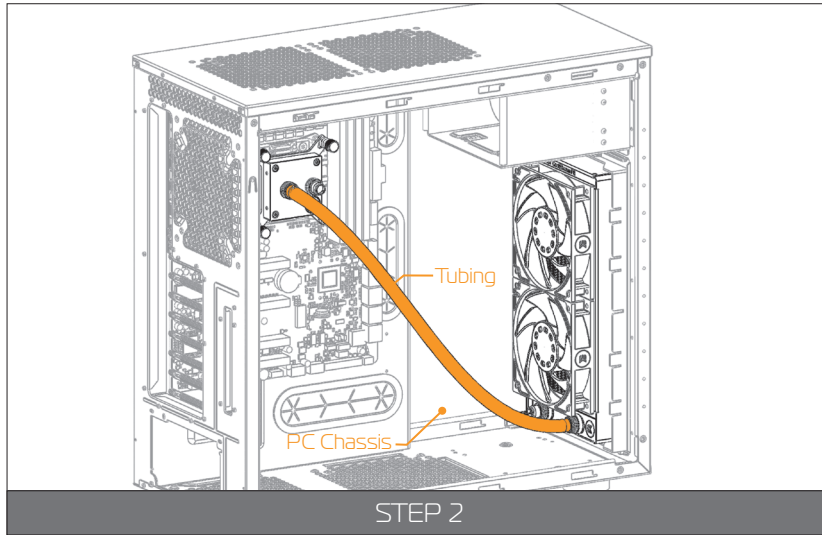

## STEP 2

Visualize the tube's routes and then measure the distance by trying to fit it into the chassis. Mark the required length with a marker. Before cutting it is recommended that you leave an additional 2 or 3 centimeters to spare. You can shorten it afterwards.



Please make sure that the tube is not bent or twisted. This way the coolant will be able to flow without restriction.

## STEP 3

It is mandatory to use the correct INLET and OUTLET port (where prescribed).

Please use the appropriate G1/4 threaded ports as shown on the picture.

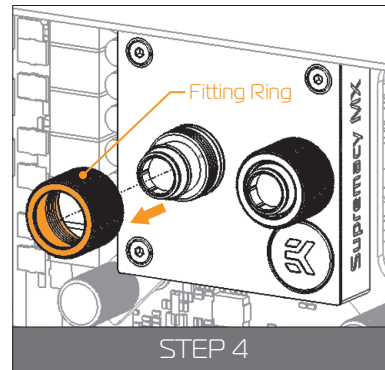
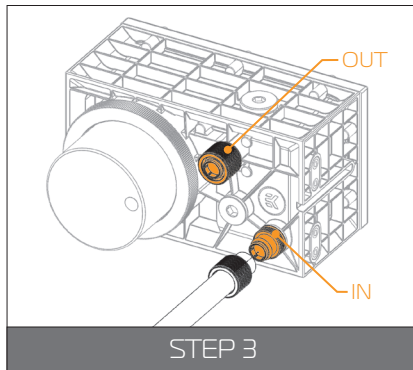

## STEP 4



If you have assembled the components according to this installation manual you should have all the compression fittings installed.

In order to install the tubing onto the compression fittings you will have to remove the fitting compression rings by rotating it in counter-clockwise direction.

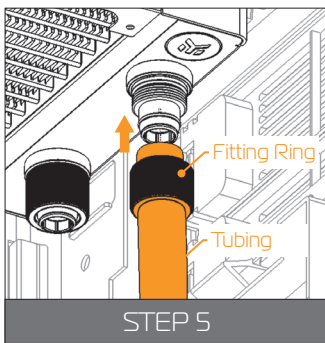

STEP 5

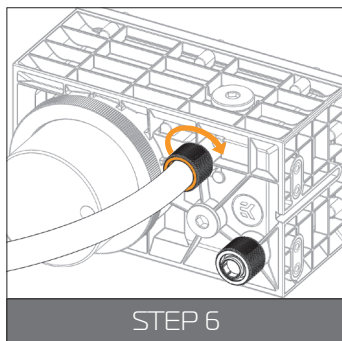

STEP 6

### STEP 5

Slide the fitting ring along the tube with the threaded side facing the fitting barb.

Install the tube on fitting barb. If needed heat the tube in warm water. You can do that by forcing it to slide over the edge as far as it goes.

### STEP 6

Slide the fitting ring towards the barb and tighten it in clockwise direction as far as it goes.

Repeat the procedure on all the fittings in order to connect the water cooling loop.

## ELECTRICAL CONNECTIONS

### CONNECTING THE PUMP-RESERVOIR UNIT

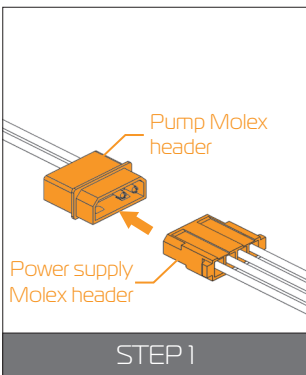

STEP 1

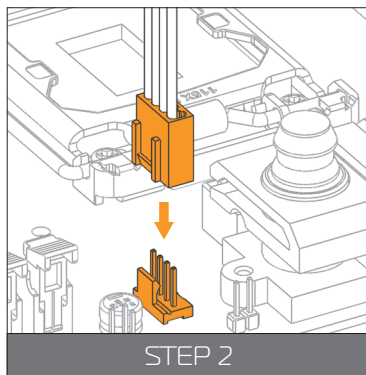

STEP 2

### STEP 1

Connect the 4-pin Molex male connector to the male Molex connector of the power supply.

### STEP 2

Take the 4-pin female connector and plug it to the male connector header located on the motherboard. Always use CPU-dedicated fan headers if possible.



Always use CPU fan header. On majority of motherboards these headers usually offer best PWM regulation.

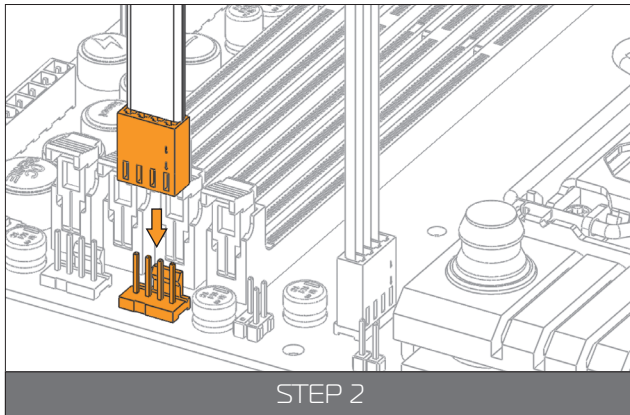
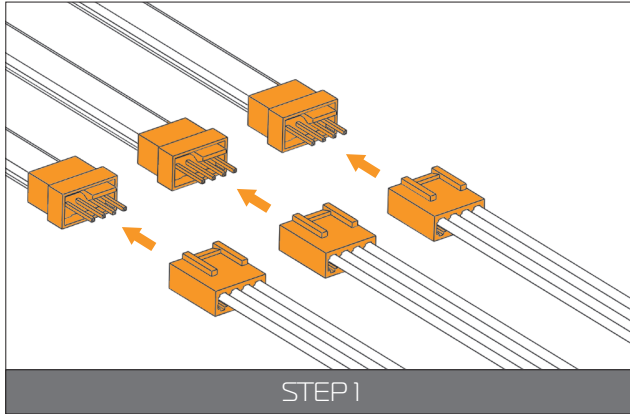

## CONNECTING THE FANS

### STEP 1

To connect the fans you might need EK-Cable Y splitter.



The EK-Cable Y splitter is enclosed with the KIT delivery.

Connect the female connectors from the fans with male connectors on the fan splitter cable.

### STEP 2

Connect the female EK-Cable Y splitter connector to the male connector header located on the motherboard. Always use CPU-dedicated fan headers if possible.



Always use CPU fan header. On majority of motherboards these headers usually offer best PWM regulation.

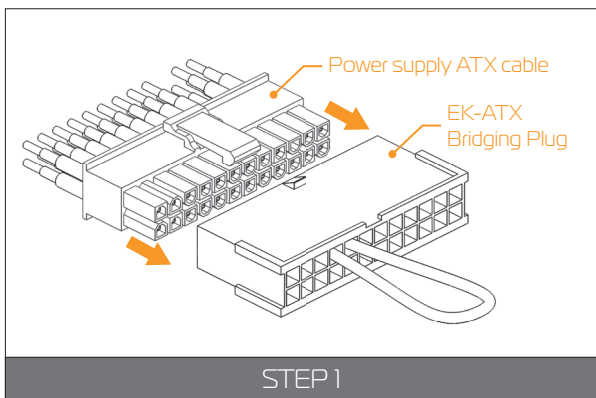

## RECOMMENDED FILLING AND LEAK-TESTING PROCEDURE

### STEP 1

It is mandatory to do the following:

1. Disconnect all PSU power connectors (4/8-pin ESP, 24-pin ATX, PCI-express power, SATA power) in your computer.
2. Plug the EK-ATX Bridging plug (enclosed) to your 24-pin ATX PSU cable which allows jump starting your computer.

This procedure requires only the pump to be connected to the power supply (PSU). Everything else needs to be disconnected!



This steps must be done to prepare the power supply for the pump in order to fill the water cooling loop with coolant and run a leak test.

Your system is now ready to be charged for the first time.

## FILLING THE SYSTEM FOR THE FIRST TIME

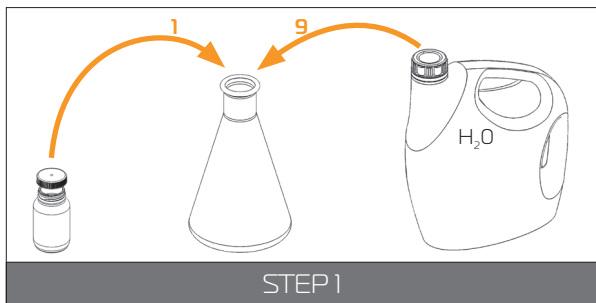

### STEP 1

#### Preparing the cooling liquid.

The coolant comes in concentrated form. In order to prepare the cooling liquid you must take a 100mL clear coolant concentrate, which is enclosed with the kit, and mix it with 900mL of distilled water.

Make sure you mix the mixture properly before pouring it into the water cooling loop.



Store the remaining liquid into a PET bottle. Do not use any food or beverage container!

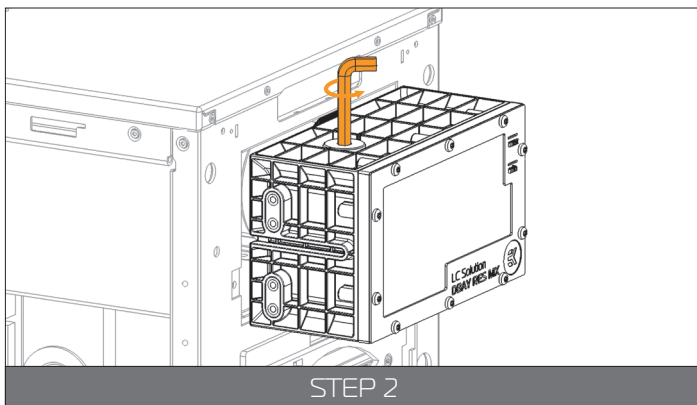

## STEP 2

Unscrew top G3/8 plug using enclosed Allen key (6mm).

## STEP 3

Fill the reservoir through G3/8 threaded fill port on top of the reservoir and make sure liquid is not spilled over your computer or any electrical devices nearby.



It is recommended to protect the exposed hardware with a few paper towels in case of a leak or to prevent spillage of coolant during charging process.

Take the pre-mixed coolant and pour it into the reservoir, until the coolant level is between lowest and highest recommendable water levels indicated on the reservoir's front panel (MIN, MAX).

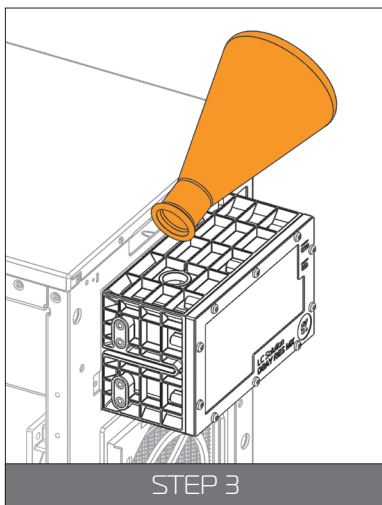

## STEP 4



Please check again if you have plugged in the EK-ATX Bridging plug. Refer to page 23, chapter RECOMMENDED FILLING AND LEAK-TESTING PROCEDURE.

Turn the power supply on briefly and check that only the pump is running.

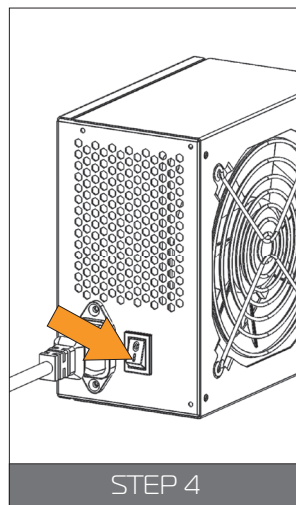

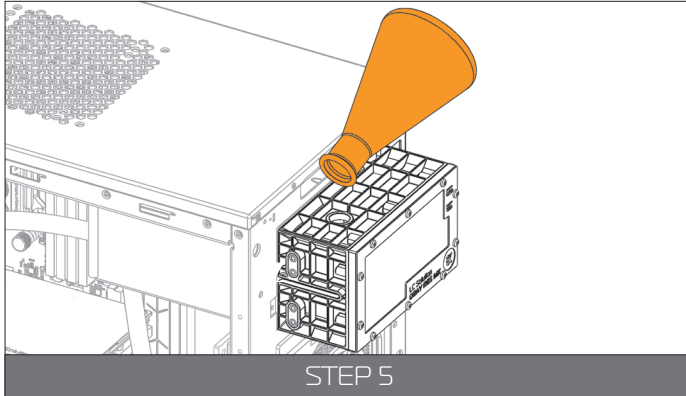

STEP 5

## STEP 5

Run your pump shortly for few seconds couple of times to make sure water floods your tubes and other water cooling components before permanently leaving the pump on. Pay attention to water level in your reservoir. Lowest and highest recommendable water levels are indicated on the reservoir's front panel (MIN, MAX).



Alternatively you can cycle (turn on and of) the power supply in few second intervals to speed up the air bleeding process.

Once done with the filling process please close your EK-DBAY D5 MX reservoir with G3/8 plug and tighten the seal using enclosed Allen key (5mm).



Upon initial filling (charging) of the system please proceed to Page 18, chapter INSTALLING THE PUMP-RESERVOIR UNIT, STEP 3 and install the pump-reservoir unit in your computer chassis.

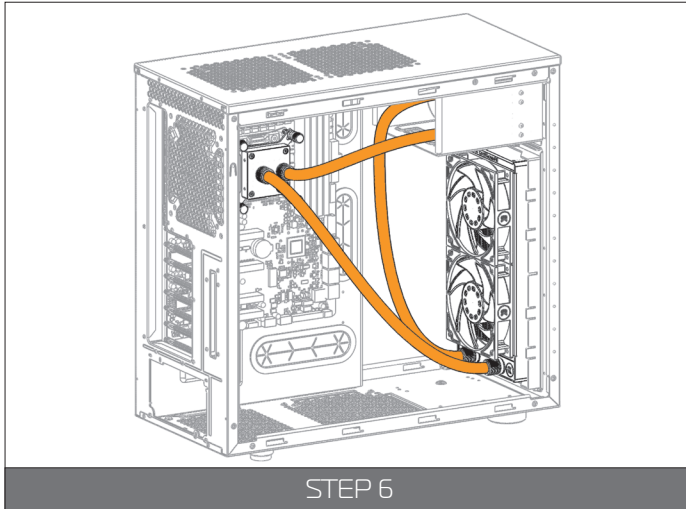

STEP 6

## STEP 6

If necessary, shake and tilt the PC chassis to remove any air possibly trapped in the radiator. You may need to add more coolant.

## 24 HOUR LEAK TEST



It is best practice to run your pump for at least 24 hours in order to ensure the system is leak free. Once the 24 hour leak test has been completed and there is no sign of leaking fluid you are free to finish your computer build.

You will not be needing the ATX Bridging Plug cable anymore. Connect all the necessary cables to the motherboard, graphics card and expansion drives.

# DRAINING OF THE LOOP

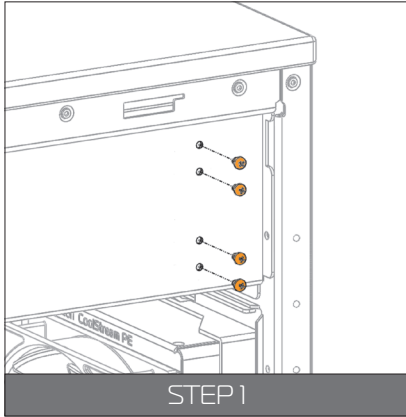

STEP 1

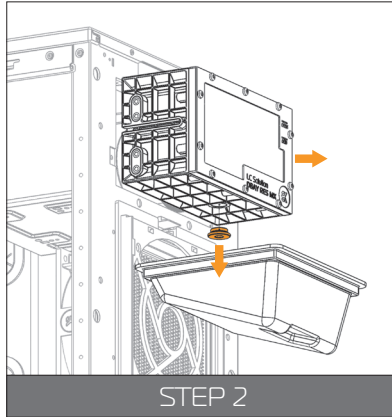

STEP 2

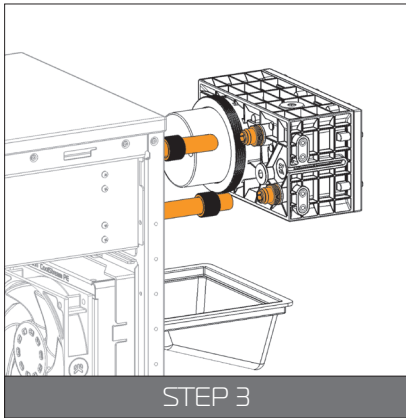

STEP 3

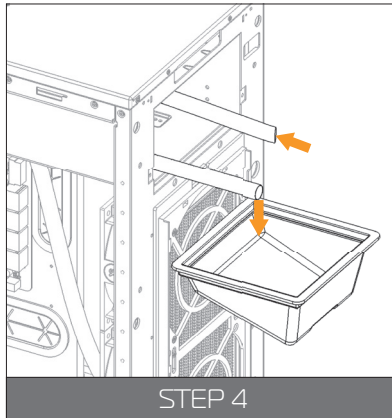

STEP 4

## STEP 1



Before disassembling the water cooling loop it is mandatory turn off your computer and pull the power cord from the socket. Prepare some paper towels and stack them over the hardware.

Unscrew the eight M3 nuts securing the pump-reservoir unit on the drive bay cage. Slowly pull the pump-reservoir unit from drive bay cage, outside of the case. Do not pull the tubing off the fitting at this stage.

Take a container and put it under the pump-reservoir unit.

## STEP 2

Unscrew the G1/4 on the bottom of the pump-reservoir unit, using enclosed Allen key (6mm).

Let the coolant flow into the container.

## STEP 3

Disconnect the tube and drain the rest of the coolant into the container.

## STEP 4

Keep one tube directed in the container and gently blow into the other tube to additionally drain the system.

To thoroughly drain the system, you can tilt the chassis in multiple directions.



## POSSIBILITIES OF EXPANDING THE SYSTEM

The best part of custom water cooling loop is that the system can be extended and the cooling capacity can be extended almost without limitations.



**For maximum performance, the rule of thumb is to use at least one 120mm radiator (section) per each water cooled component plus one 'spare'.**

For example, if one is liquid cooling a CPU and a single high-performance graphics card it is recommended at least one 240mm (2x120mm) radiator for best possible performance. Ideally, one would get a 360mm (3x120mm) radiator for best performance. Motherboard- and memory water blocks usually have lower power output therefore they are not included in this equation

In this manual we will expand the loop with an additional GPU full cover water block. You can also expand the loop with an additional radiator, reservoir, motherboard block..

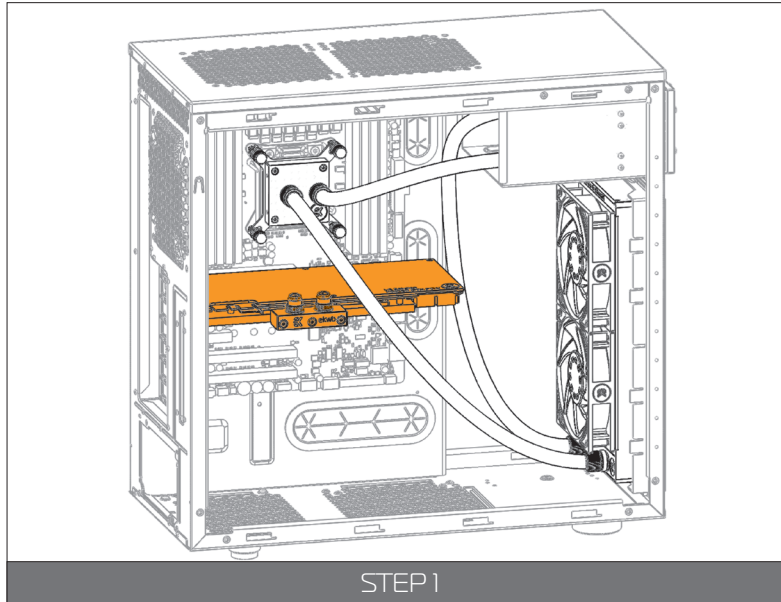

### STEP 1



If already filled, drain the water cooling loop according to the instructions in the chapter DRAINING OF THE LOOP.

Install the unit, with which you are expanding the system according to its installation manual. When positioning it in the loop take notice that water blocks must receive the coldest coolant as possible.

Carefully determine the optimal tube routing and install the compatible fittings (10/13mm) and optionally the plugs.

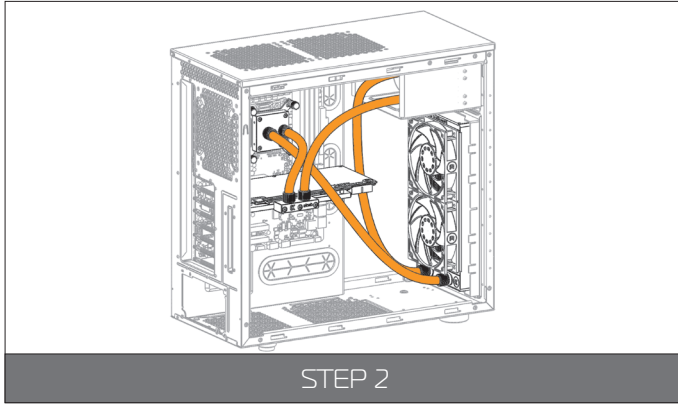

## STEP 2

Measure the length of the tube that is needed to connect the CPU to GPU water block and the GPU water block to the pump-reservoir unit. You can use a pair of scissors or a knife to cut the tube.



You may need an additional tubing to connect the water block.

Attach the tube onto the both fitting barbs until it sits firmly. Secure the fitting compression ring to make the assembly complete. Check again that all of the tubing is secured by compression fittings as intended. If it is not, please repeat STEP 1 to STEP 5 of chapter CONNECTING THE TUBING.



Fill the system by following the steps in the chapter FILLING THE SYSTEM FOR THE FIRST TIME.

## MAINTENANCE

In order to obtain the best performance through whole lifespan of the product it is crucial to follow these maintenance tips:

### TIP 1: DUST REMOVAL

It is mandatory to remove the dust every **2-3 months**. EK recommends to use a vacuum cleaner or compressed air to blow the dust away. The most dusty is usually the radiator so pay special attention to that. Do not forget to turn off the computer and unplug the power supply. It is recommended to remove the dust outside.

### TIP 2: CHECKING ELECTRICAL COMPONENTS

**Once a year** you should check the pump and the fans, if they are running as

they should. The pump and fans must run silently without any rattling noises and must react to PWM duty cycle changes. All imperfections may lead to overheating and breakdown.

### TIP 3: CLEANING THE UNIT (RELATED TO CHAPTER TROUBLESHOOTING)

**Every year** the unit should be thoroughly cleaned. You must let all the coolant out (Page 28). The radiator must be flushed and the pump checked and cleaned. It is recommended to change the tubing.

### TIP 4: USE EK DESIGNED AND MANUFACTURED PARTS ONLY

It is recommended to use only genuine EK Water Blocks liquid cooling gear, parts and add-ons to prevent any performance, compatibility and warranty issues.

### **Q** Is this kit, namely the water block, compatible with narrow server type LGA-2011 motherboard? How about older LGA-1366 and -755?

A: Narrow server type LGA-2011 is not supported by default – a Mounting plate Supremacy LGA-2011 Narrow ILM [EAN: 3830046990600] is mandatory to install this water block on narrow server type LGA-2011 motherboards. Replacing the mounting plate requires disassembly of the water block.



LGA-1366 and LGA-775 owners should follow the installation manual for installation on AMD® socket motherboards. However it is required to remove the inner core of the CPU backplate rubber gasket. This is true for both scenarios.

### **Q** How many water blocks can you add to the loop?

A: EK-KIT GAMING liquid cooling unit can be upgraded with several additional parts. However in order to keep performance at a reasonable level it is recommended not to upgrade EK-KIT GAMING with no more than:

- one (1) GPU water blocks (EK-KIT G240)
- two (2) GPU water blocks (EK-KIT G280, EK-KIT G360)

The pump itself can manage the restriction of having up to 4 GPU water blocks however the loop has to be extended with an additional radiator units.

### **Q** What flow rates are to be expected with EK-KIT GAMING?

A: This kit typically operates at about 295L/h with pump set at full speed. Installing a typical GPU water block typically drop flow rates from

295L/h to about 240L/h. Adding two water blocks would result in flow rates of about 200L/h in the same scenario.

For best performance it is recommended to run the pump at 100% duty cycle in order to maintain highest flow rates (and thus thermal performance) when running more than one additional water block.

### **Q** Can the Push-Pull Fan configuration be used with EK-KIT G?

A: Yes, this kit can take accommodate additional fans on the bottom side and thus work in push-pull regime. However, the required mounting screws are not enclosed and must be purchased separately. In order to prevent damage to the unit please use the UNC 6-32 30mm screws with standard 120x120x25mm fans!

The required set of UNC 6-32 x 30mm screws can be purchased through EK Webshop and EK Partner Reseller Network.



### **Q** Is it possible to 'daisy-chain' the enclosed PWM splitter?

A: Yes, the enclosed PWM splitter allows for daisy-chaining of additional PWM splitter cables, such as EK-Cable Y-Splitter 2-Fan PWM (10cm) [EAN: 3831109867860], as long as the total power draw does not exceed 12W (1A on +12VDC) - the limit of KK 254 4-pin fan header on the motherboard.

## Q What thermal performance is to be expected from the EK-KIT G unit?

A: The nominal cooling capacity of the EK-KIT G units is listed in the table below:

	dT=10K	dT=15K
KIT G240 *	302W	453W
KIT G360 *	453W	680W
KIT G280 **	398W	597W

\* = Vardar 120 @ 1850rpm

\*\* = Vardar 140 @ 1500rpm

The nominal capacity tells how much heat is the kit unit able to move with 10°C (10K) or 15°C (15K) increase in liquid temperature over ambient.

Example: Ideally, the KIT G240, cooling an overclocked LGA-1151 Skylake Core i7 CPU (150W) and the NVIDIA GeForce GTX 1080 class GPU (225W) would achieve liquid temperatures of about 13°C above ambient during maximum combined (synthetic) workload. Given the ambient temperature of 22°C, this would result in liquid temperature of around 35°C in ideal situation. One can usually expect 10-15°C higher GPU core temperature (GPU 45-50°C).



The same formula works for majority of hardware as long as the correct TDP value is used.

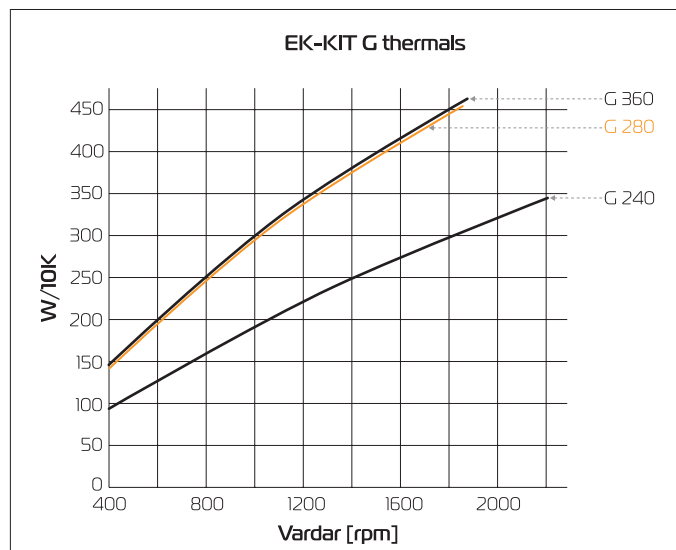

## IN CASE OF CPU OVERHEATING:

Very high CPU temperatures are usually the symptoms of malfunctioning liquid cooling loop, assuming the contact between CPU heat spreader and water block itself is good and that the water itself is adequately cooled within the radiator. This can occur either due to:

**1. Malfunctioning or non-working water pump:** The symptoms usually include rapid spike in temperature when stressing your CPU to the maximum (for example with Prime95 software). Make sure the pump is plugged in to the power connector and that the liquid is indeed flowing in your system. You should feel the pump vibrating in your hand. Observe the flow indicator or flow meter reading if present.

**2. Malfunctioning or non-working cooling fans:** The symptoms usually include rapid spike in temperature when stressing your CPU to the maximum. Make sure the cooling fans are plugged in to the power connector hub and that the blades are indeed rotating.

**3. Kink in the liquid cooling tubing:** Very similar symptoms to both above described. Thin-walled tubing may collapse easily under low radius turns or when obstructed by other computer chassis elements such as closing side panel doors. Check the tubing for any signs of kink which restrict the flow. This is normally not the case when using original tubing.

**4. Clogged microchannels in the water block:** Microchannels can get clogged easily with various dirt particles and impurities, especially with plasticizer powder which has leached from the tubing (When using unsafe liquid cooling tubing). The symptoms usually include rapid spike in temperature when stressing your CPU to the maximum, flow rates are very low. Visually inspect the water block internals for any buildup or contamination and clean the system if necessary. In case the water block with translucent acrylic top is employed this inspection can be done without disassembling the system.

**5. Thermal interface material (paste/grease) not applied or applied improperly:** Lack of - or even too much TIM - may result in CPU overheating. Please refer to STEP 2 in Installing the water block section.

**6. Cooling liquid (coolant) freezing:** Running the system in an subzero temperature environment may lead to liquid freezing. The symptoms include initial rapid spike in the temperatures when stressing your CPU, followed by substantial drop after the liquid partially thaws. Always make sure the system is operating in an environment where ambient (room) temperature doesn't drop below 5°C.

Another culprit could be partially or completely defective CPU. Some CPUs run at higher temperatures than the others. Overheating of the CPU can also occur due to:

**1. Poor thermal contact within the CPU itself:** Some CPUs, such as Intel LGA-1151 socket based Skylake, Intel LGA-1150 based Haswell and older, socket LGA-1155 based Ivy Bridge are notorious for their poor thermal contact between the CPU die and the heat spreader (IHS) itself due to the use of poor TIM. This is the problem of the processor and not the CPU liquid cooling unit. These CPUs are known to run very hot (80°C+) even on factory set frequencies. For best performance it is usually recommended to replace the TIM between the die and the IHS or to even run the processor de-lidded. Both require hazardous IHS removal which voids processor's warranty but can lead to temperature decrease of 30°C and higher.



EKWB deems der8auer Delid Die Mate tool safe to be used by experts for de-lidding of the Intel Skylake CPUs.



Upon exhausting all options please consult EK knowledge base at <http://support.ekwb.com> . Raise a question through EK Support ticketing system if needed.

## THE COOLER IS TOO LOUD

The Predator unit is equipped with fast-spinning EK-Vardar high-static pressure PWM controlled fans, which run at very high speed if the UEFI/BIOS is not set to control fan speed. Make sure to set control mode to PWM (instead of DC)! On majority of motherboards this feature can be found in 'Hardware Monitoring' section of the UEFI/BIOS. Please consult your motherboard manual on how change fan speed.

### General ASUS Z170/X99 motherboard guide:

1. Enter UEFI and go to QFAN Control
2. Select the FAN header you wish to edit (the one that you have connected the Predator's PWM cable to)
3. Select PWM mode (instead of DC)

### General ASRock Z170/X99 motherboard guide:

1. Enter UEFI and go to H/W Monitor
2. Choose the FAN header you wish to edit (the one that you have connected the Predator's PWM cable to)
3. Change from 'Full Speed' to 'Silent', 'Standard' or 'Performance' mode

### General Gigabyte Z170/X99 motherboard guide:

1. Enter UEFI and go to M.I.T. -> PC Health Status
2. Select (CPU Fan) Speed Control optionbox and select 'Auto', 'Normal' or 'Manual'.

### General MSI Z170/X99 motherboard guide:

1. Enter UEFI and go to Hardware Monitor
2. Select the FAN header you wish to edit (the one that you have connected the Predator's PWM cable to)
3. Enable Smart Fan Mode Checkbox
4. Change ramp-up curve by dragging and dropping 4 colored squares



Make sure the 4-pin PWM Fan connector is indeed plugged in correctly into the appropriate FAN header on your motherboard. Please consult page 21, chapter ELECTRICAL CONNECTIONS.

## GENERAL LIQUID COOLING PARTS CLEANING GUIDE



Liquid cooling parts may be disassembled for cleaning purposes on an occasional basis. Your warranty is not voided on disassembly of the water block but the customer loses the EK leak-free guarantee which comes with a factory tested Component. And old, but soft toothbrush is an excellent cleaning tool!

**1. Cleaning bare copper:** When cleaning bare copper it is recommended to use slightly acidic cleaning agents which include the following organic agents:

- (white) vinegar (acetic acid up to 5-10%)
- lemon juice (citric acid up to 5-10%)

Certain food can also be used for cleaning copper:

- cola (contains phosphorous- and citric acid)
- ketchup or tomato extract (contains acetic- and citric acid)
- mustard (contains acetic acid)



5% vinegar, diluted with 95% water is enough to kill 99.9% of algae and bacteria that could be present on copper in an unmaintained cooling loop as well.

Upon cleaning it is necessary to flush the water blocks in water and rinse them with distilled water. After rinsing we recommend soaking the water blocks in paper towels until completely dry. It is nearly impossible to avoid the naturally occurring copper tarnishing (oxidation) as the oxidation will reoccur the moment the copper is cleaned of the all oxides.

**2. Cleaning nickel plated copper:** When cleaning nickel plated copper it is forbidden to use any aggressive chemicals (neither vinegar) or rough materials as you may damage the plating and thus void the warranty. Please note also that due to presence of dye additives and other chemicals the nickel layer may also become discolored/stained over time period. However the staining is normally reversible by simple flush and rinse. Cleaning the nickel plated copper should consists of these steps:

- flush the nickel plated copper under warm water
- clean the surface using wet non-abrasive cloth and rinse with clean water
- polish the hardened deposits (such as algae or dirt) from the nickel plated copper if necessary.

EK recommends the use of automotive soft, non-abrasive metal polish cremes. After you finish using other cleaning methods, give the nickel plating a good polish with a non-abrasive metal or chrome polish. Apply a small amount of polish to a cloth or to the surface of the nickel. Wipe the entire surface of the nickel with the polish, using small circular motions, until it looks shiny and clean. Use another clean cloth to remove the remains of the polishing paste from the surface. Always rinse with distilled water after you are done with polishing.

### 3. Cleaning acrylic (plexi) glass tops:



Acrylic will fail prematurely if subjected to even small amounts of alcohol, acetone or other aggressive chemicals.

Please do not use anything but warm, soapy water and a toothbrush to clean the acrylic (plexi) glass water block tops and reservoir tubes. Using aggressive chemicals will surely void your warranty!



Algae- or dirt deposits may be rubbed out using soft cloth in combination with warm, soapy water. Rinse with distilled water after cleaning.

**4. Cleaning POM (acetal) tops:** POM (polyoxymethylene) or Acetal can withstand chemicals such as alcohol or acetone but EK recommend to use these very sparingly as the drying chemicals will surely leave some residue. Usually the POM can be cleaned easily just be the use of soft cloth and warm, soapy water - without the use of any chemicals. Rinse with distilled water after cleaning.

## PREVENTIVE STEPS

**1. Using corrosion inhibiting coolant** (such as EK-Ekoolant or other market proven coolant) is highly recommended for any water cooling loops. Since EK-Ekoolant is also a surfactant is will prevent algae growth and dirt deposition on all wetted surface.

**2. Refrain from using** Copper Sulphate based additives in your loop in order to prevent tarnishing on your water cooling gear internals!

## SUPPORT AND SERVICE

For assistance please contact:

<http://support.ekwb.com/>

EKWB d.o.o.  
Pod lipami 18  
1218 Komenda  
Slovenia - EU

## SOCIAL MEDIA

 EKWaterBlocks

 @EKWaterBlocks

 ekwaterblocks

 EKWBofficial

 ekwaterblocks

