

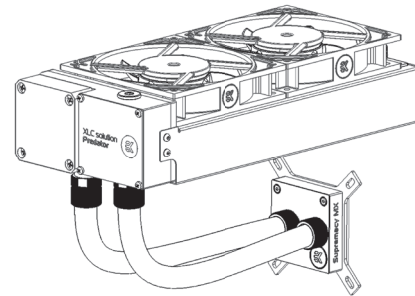

For EK-XLC Predator series units | 4th Revision, Jul 15th 2016

Pre-filled CPU Xpandable Liquid Cooling

EK-XLC PREDATOR

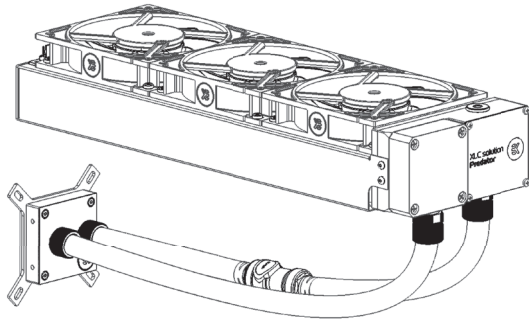

USER GUIDE

EK Water Blocks bears the name of its founder Edvard König, who started experimenting with liquid cooling in 1999. From the humble beginnings in the early years of the previous decade, the company grew steadily to become a global premium liquid cooling gear manufacturer. Today, EKWB offers a complete range of products for liquid cooling, from a renowned Supremacy line of CPU water blocks, wide range of CoolStream radiators to in-house developed Vardar High pressure fans, providing overclocking enthusiasts and PC builders with the best of what the market can offer. Predator all-in-one (AIO) eXpandable Liquid Cooling (XLC) solution is the next step to bring extreme liquid cooling performance in the hands of dedicated gamers and PC enthusiasts around the world.

Welcome to EK-World!



Safety precautions

1. Keep and store the product away from the reach of children.
2. Check the component list and condition of the product before installation. If there is any problem, contact the shop where you have purchased the product to get a replacement or refund.
3. EKWB d.o.o. is not responsible for any damages due to external causes, including but not limited to, improper use, problems with electrical power, accident, neglect, alteration, repair, improper installation and improper testing.
4. CPU, motherboard and/or other computer components are subject to damage if the product is incorrectly installed.
5. This product is All-In-One eXpandable CPU liquid cooling solution. Disassembling it and combining with parts, other than EK Water Blocks products, may lead to warranty loss.
6. Product warranty period is 24 months.

TABLE OF CONTENT

SCOPE OF DELIVERY	3	INSTALLING TRANSPARENT TUBING (OPTIONAL)	22
REQUIRED TOOLS	3	MAINTENANCE	22
VIDEO INSTALLATION GUIDES	3	FREQUENTLY ASKED QUESTIONS	23
QUICK INSTALLATION GUIDE		TROUBLESHOOTING	25
RADIATOR SPACE CONSTRAINT REQUIREMENTS	4	IN CASE OF CPU OVERHEATING.....	25
EK-XLC PREDATOR 240.....	4	THE COOLER IS TOO LOUD.....	26
EK-XLC PREDATOR 360.....	5	GENERAL LIQUID COOLING PARTS CLEANING GUIDE	26
EK-XLC PREDATOR 140.....	6	PREVENTIVE STEPS.....	27
EK-XLC PREDATOR 280.....	7	PART SPECIFICATION LIST	28
UNIT ORIENTATION LIMITATIONS	8	PUMP.....	28
ELECTRICAL CONNECTIONS	9	FITTINGS.....	28
CONNECTING THE HUB TO THE POWER SUPPLY.....	9	FAN SPLITTER HUB.....	29
CONNECTING THE HUB TO THE MOTHERBOARD.....	9	FANS.....	30
INSTALLING THE PUMP/FAN/RADIATOR UNIT	10	THERMAL GREASE.....	30
GENERAL INFORMATION ON WATERBLOCK COMPATIBILITY	11	TUBING.....	30
INSTALLING THE WATER BLOCK	12	SUPPORT AND SERVICE	31
LGA-2011(-3) SOCKET MOTHERBOARDS.....	12	SOCIAL MEDIA	31
LGA-115X SOCKET MOTHERBOARDS.....	13		
POSSIBILITIES OF EXPANDING THE SYSTEM	16		
EK-XLC PREDATOR WITH QUICK-DISCONNECT COUPLINGS (QDC).....	16		
Preparing the Predator unit.....	16		
Connecting the pre-filled water block with QDCs.....	17		
EK-XLC PREDATOR WITHOUT QUICK DISCONNECT COUPLINGS (QDC).....	18		
Disassembly.....	18		
Adding components to the loop.....	19		
Filling up the system.....	19		
Adding an external reservoir.....	21		

SCOPE OF DELIVERY

All-in-one expandable liquid cooling unit

EK-XLC Predator (incl. QDC)

**240
360
140
280**

OR

EK-XLC Predator

**140
240**

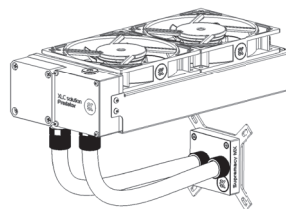
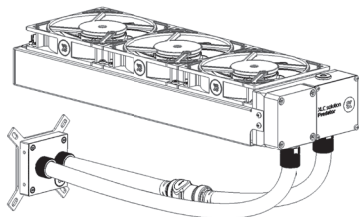

CPU Backplate mechanism

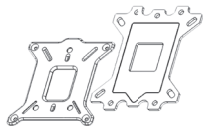

Thermal grease

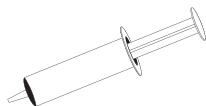

CPU Mounting mechanism

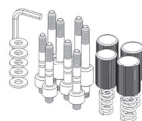

Installation manual



REQUIRED TOOLS

Phillips-head screwdriver

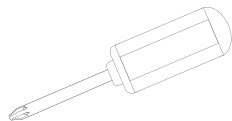

VIDEO INSTALLATION GUIDES



Our official YouTube channel features video installation guides, that can help you with Predator installation. Scan the QR code to visit our YouTube channel.

RADIATOR SPACE CONSTRAINT REQUIREMENTS

EK-XLC PREDATOR 240

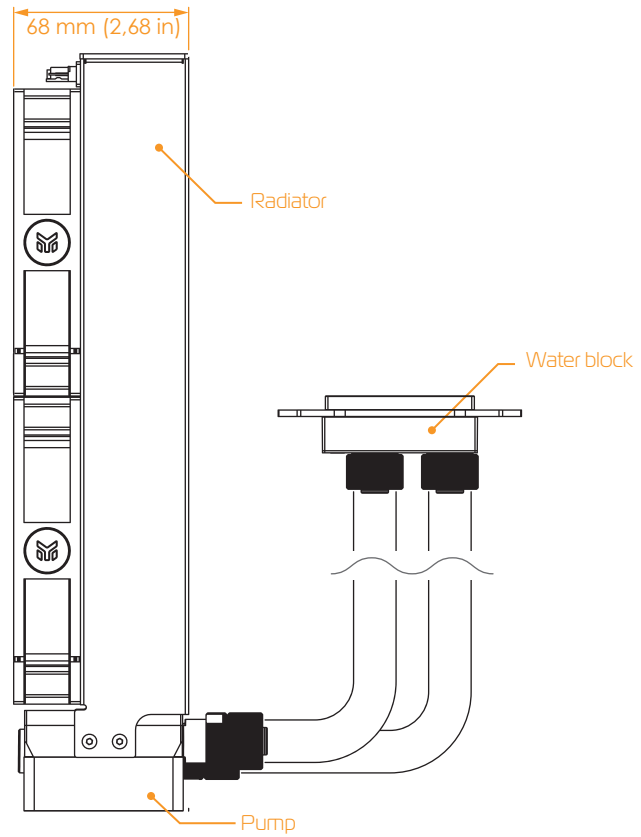
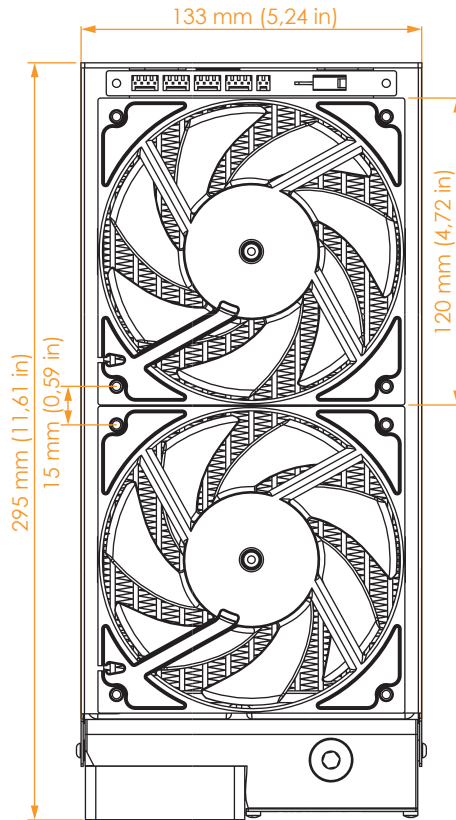

EK-XLC PREDATOR 360

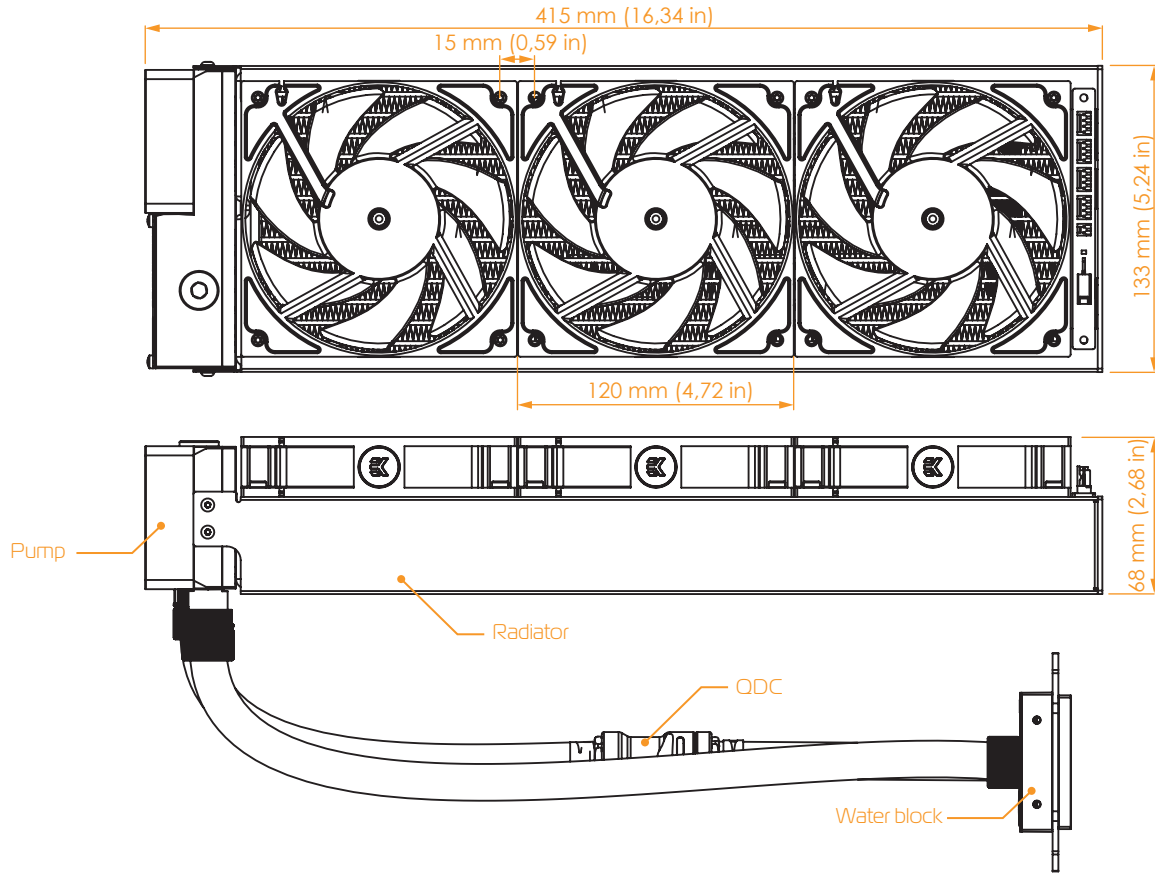

EK-XLC PREDATOR 140

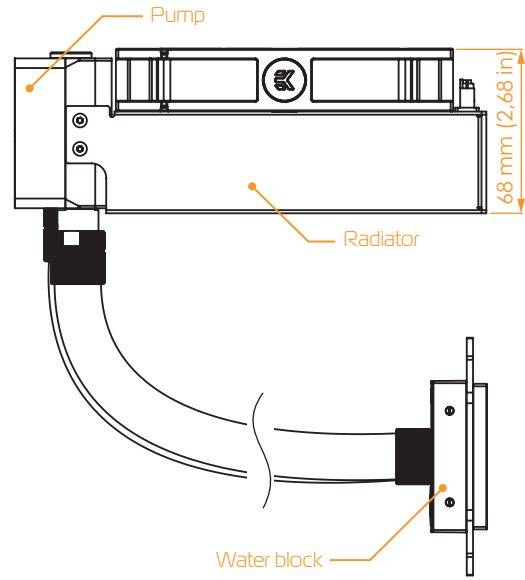
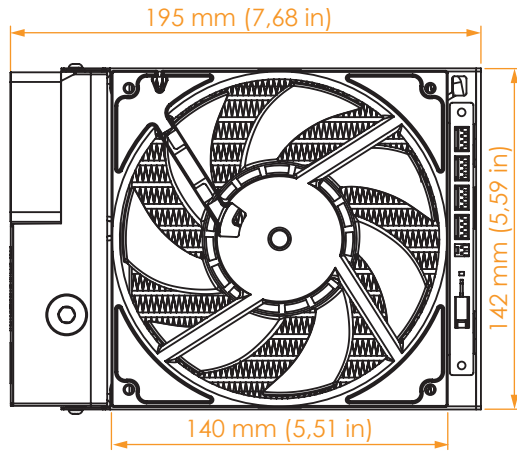

EK-XLC PREDATOR 280

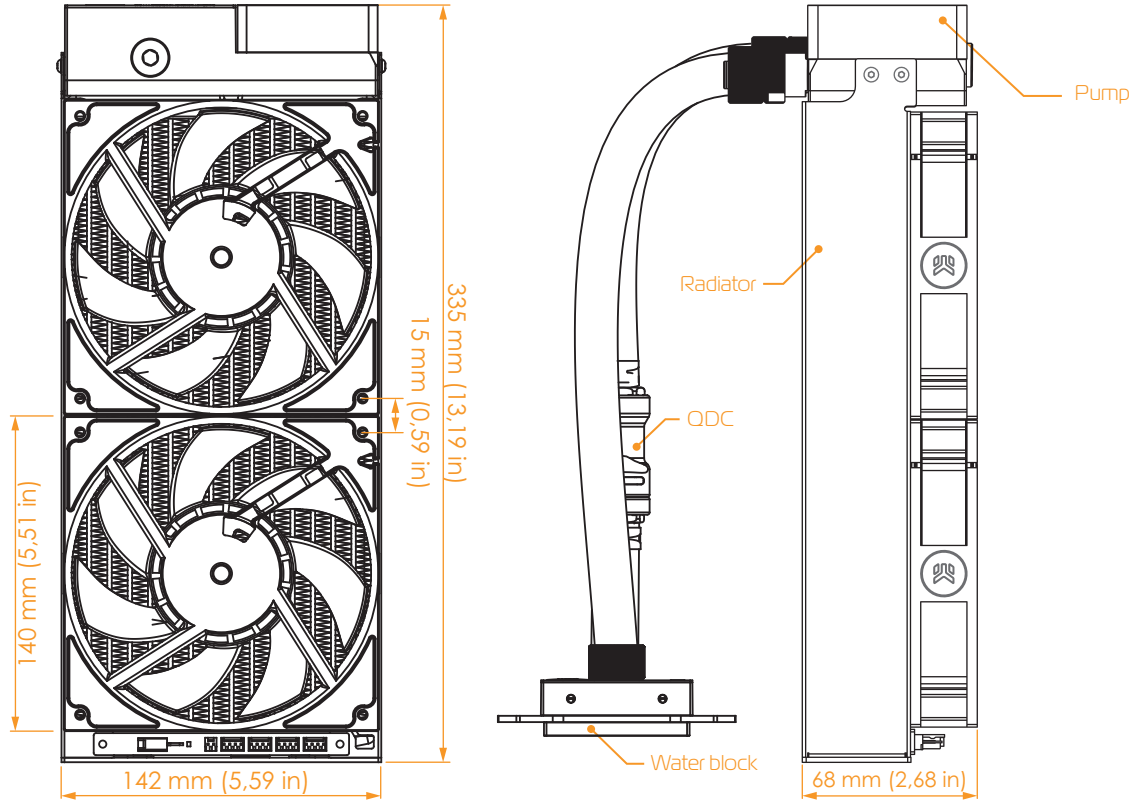

UNIT ORIENTATION LIMITATIONS



CAUTION:
The orientation of the unit is very important as wrong installation may lead to insufficient cooling performance and premature failure of the unit.

The orientation limitations stands for all versions of the Predator unit.

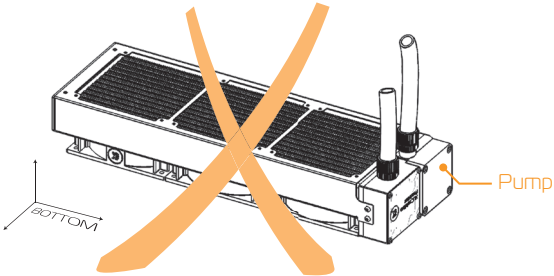
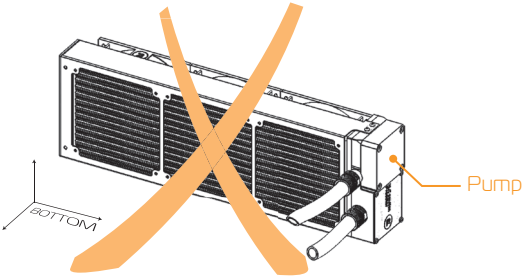
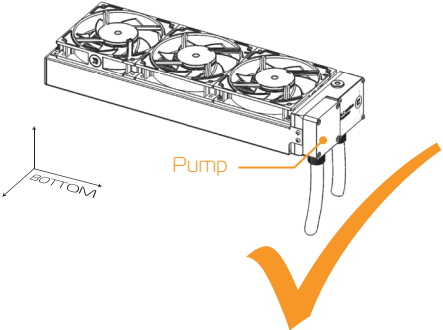
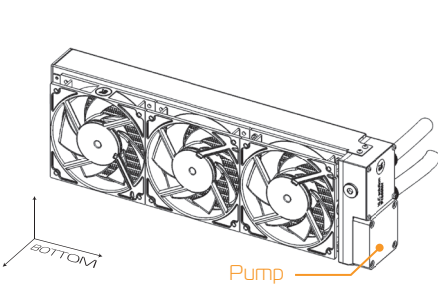
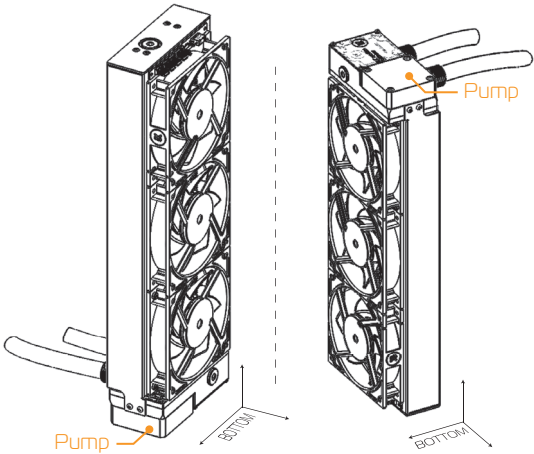

ELECTRICAL CONNECTIONS

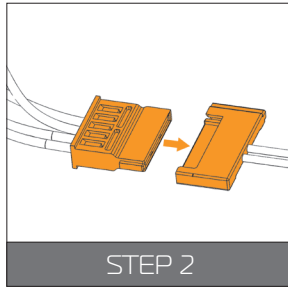
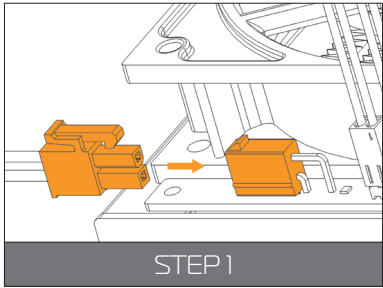

CONNECTING THE HUB TO THE POWER SUPPLY

STEP 1:

Take the enclosed power cable and plug the two-pin PCI-express minifit power connector to the fan splitter hub.

STEP 2:

Use the SATA POWER connector at the other end and plug it to the female connector found on the main power supply.

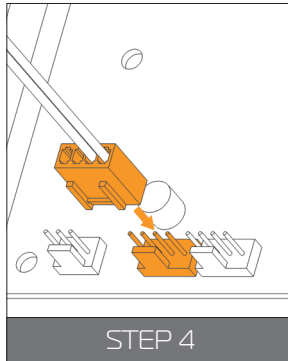
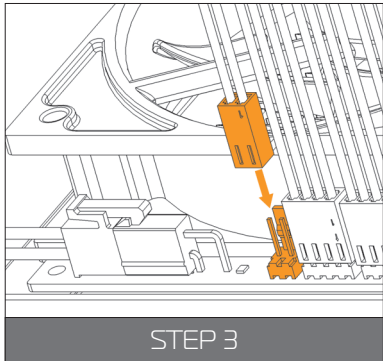

CONNECTING THE HUB TO THE MOTHERBOARD

In order to obtain the PWM fan speed control you must follow the steps below:

STEP 3:

Take the enclosed connection cable and plug the two-pin cable connector to the fan splitter hub.

STEP 4:

Use the 4-pin connector at the other end and plug it to the male connector header located on the motherboard. Always use CPU-dedicated fan headers if possible.



Always use CPU fan header. On majority of motherboards these headers usually offer best PWM regulation.

INSTALLING THE PUMP/FAN/RADIATOR UNIT

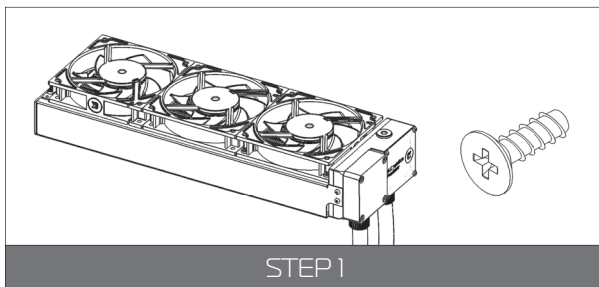

STEP 1:

Mounting of the pump/fan/radiator unit requires special attention.

Please take the unit and find the enclosed standard fan mounting screws. You will need 4 screws for the 140mm version, 8 screws for 240- and 280mm version or 12 screws for 360mm version.

You will need a philips-head screwdriver which is not enclosed in the package.

STEP 2:

Prepare your suitably-sized PC chassis for installation of EK-XLC Predator.

The position of the unit in the chassis depends on the size, fan mounting holes and the hardware you have installed.

You must make sure that the unit fits into the chassis. Usually the chassis have standard fan mounting holes pre-drilled so you should look for holes with spacing of 105mm (a standard computer 120mm cooling fan) or 125mm (for 140mm cooling fan).

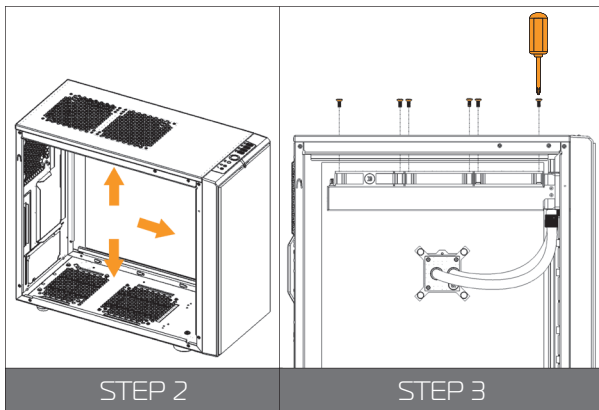

Out-of-the box, the Predator is set to work in overall hot air exhaust (by placing the radiator on the exhaust) configuration. This results in overall decrease of temperature throughout the entire computer chassis but also leads to slightly higher liquid temperatures. A reversed air flow is a viable option but one should always strive to achieve unidirectional flow of air throughout the chassis. See page 23, chapter Frequently Asked Questions, on how to change fan orientation.

STEP 3:

When you have selected the mounting position within the chassis you must align the Predator cooling fan mounting holes with the ones on the chassis.

Use enclosed self-tapping screws to firmly install the unit. Self-tapping screws require more torque than threaded screws, but overall do not exaggerate with the force applied.



Check again that the unit isn't touching the chassis anywhere except at the mounting region. Some unwanted noise may occur if the vibrations are transferred from the unit to the pc chassis.

GENERAL INFORMATION ON WATERBLOCK COMPATIBILITY

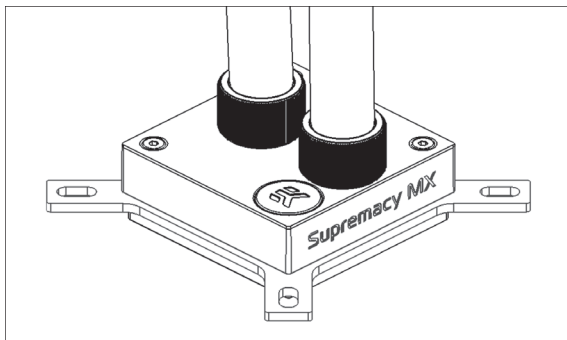

This CPU liquid cooling unit is pre-assembled for use with modern Intel desktop socket type motherboards. By default (out of the box) this water block supports the following CPU sockets:

- Intel® Socket LGA-115x
- Intel® Socket LGA-2011(-3)



Narrow server type LGA-2011 is not supported by default – a Mounting plate Supremacy LGA-2011 Narrow ILM (EAN: 3830046990600) is mandatory to install this water block on narrow server type LGA-2011 motherboards. Replacing the mounting plate requires disassembly of the water block. Legacy sockets LGA-775 and LGA-1366 are compatible when installed using optional EK-Supremacy EVO Backplate.



Compatibility with AMD socket type motherboard is ensured via optional mounting plate add-ons, available for separate purchase. Please visit www.ekwb.com for more details.



WHAT IS ENCLOSED

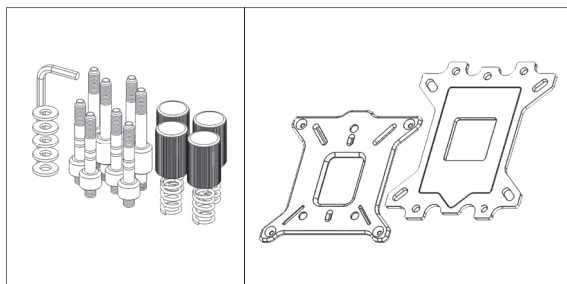

The following items are enclosed with EK-XLC Predator unit CPU water block:

- **EK-XLC Predator CPU water block**
- **PreciseMount universal CPU mounting mechanism:**
 - M4 threaded thumb screws (4 pcs)
 - LGA-2011 M4 threaded mounting studs (4 pcs)
 - Springs (4 pcs)
 - M4 threaded thumb nuts (4 pcs)
 - Washers (4 pcs)
- **EK-Supremacy Backplate**
 - Backplate for Intel LGA-115x socket motherboards with rubber gasket

INSTALLING THE WATER BLOCK

LGA-2011(-3) SOCKET MOTHERBOARDS

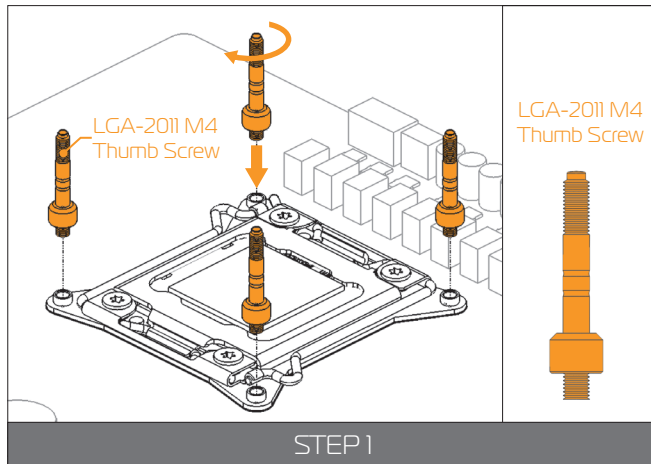

STEP 1:

Prepare the zip bag containing CPU mounting mechanism screws which was enclosed with the EK-XLC Predator unit.

Install four (4) specific LGA-2011 M4 thumb screws into four M4 threaded stubs on the LGA-2011 socket integrated latch mechanism (ILM). The screws are to be installed using no tools (i.e. pliers).



It is not necessary to remove the LGA-2011(-3) type motherboard from the PC chassis in order to install CPU water block mounting screws unless forced to do so due to space constraint limitations of certain computer chassis.

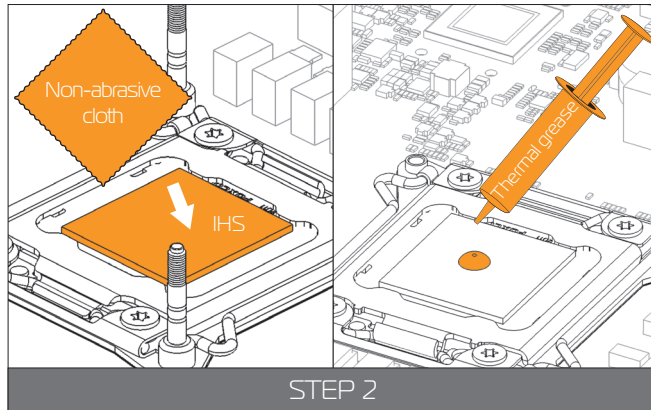

STEP 2:

Cleaning the CPU: Wipe the CPU's contact surface (by using non-abrasive cloth or Q-tip, as shown on sample photo).

Applying thermal compound: EK recommends blob or line method of applying the enclosed EK-TIM Ectotherm thermal compound to the CPU heat spreader (IHS) - see sample photo on right.



The quantity of about two rice grains is just about right. There is no need to cover the whole IHS. Applying too much thermal grease will have negative impact on the cooling performance!

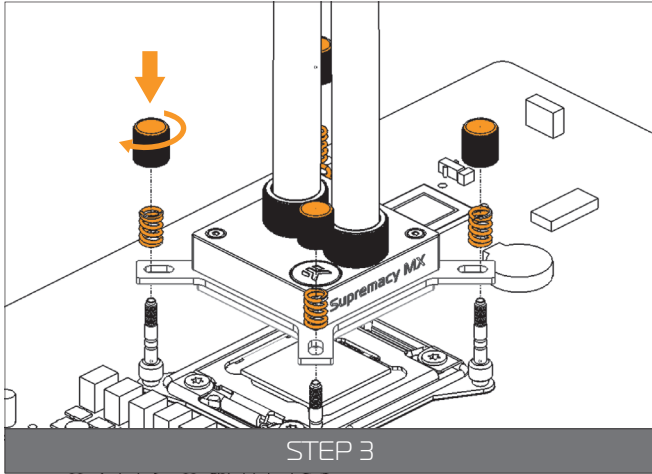

STEP 3:

Align the water block over the mounting screws on the LGA-2011(-3) motherboard with pre-installed CPU.



Before proceeding with the installation It is **mandatory** to remove the protective foil from the backside of the water block.

Place an enclosed compression spring and thumb nut over each M4 thumb screw. Start fastening two thumb nuts at a time, preferably in cross pattern and do not tighten them fully until all of them are partially screwed in. Then - using your fingers only - screw in all four thumb nuts until you reach the end of the thread. Do not use any tools (such as pliers) during this process

Your EK-XLC Predator installation on LGA 2011(-3) platform is now complete.



Starting your computer up:

Before you add the power to your computer please check if everything is installed according to the installation manual.

When turning on the computer be careful nothing is leaking and that the temperatures of the CPU are normal. It is best practice to enter BIOS/UEFI and check hardware health monitoring section on initial boot!

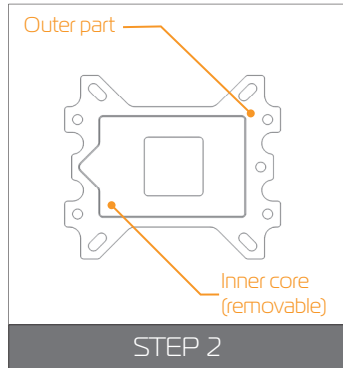
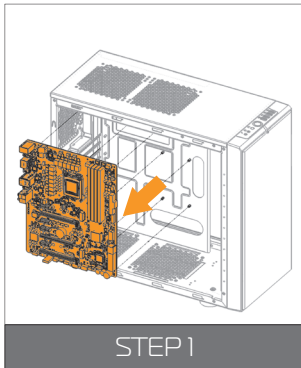

LGA-115x SOCKET MOTHERBOARDS

STEP 1:

If already installed, please remove the motherboard from your computer and place it on an even surface with front facing down.

STEP 2:

Preparing backplate rubber gasket

The enclosed rubber gasket is essential part of the backplate and mounting system and must be used every time you install this water block on your motherboard.



The rubber gasket has a partially cut inner part which needs to be removed when installed on Intel LGA-115x motherboard. The rubber is held on four places and can be peeled away with hand.

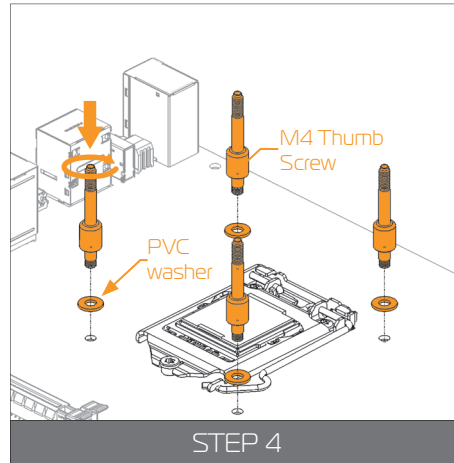
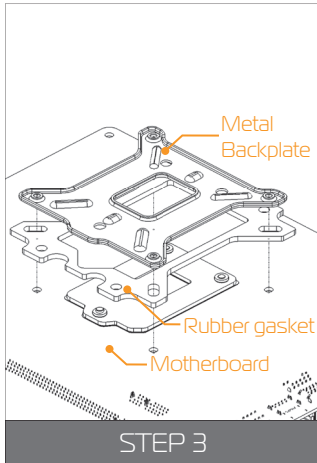

STEP 3:

Install backplate rubber gasket and place metal backplate for Intel LGA-115x socket to the back of your motherboard RIBBED SIDE UP! (facing away from the motherboard) Align the holes on the motherboard with holes on rubber gasket and backplate.



Make sure to orientate the rubber gasket to fit past the CPU socket ILM backplate.

Carefully rotate motherboard assembly with front side facing up with one hand while holding the backplate and rubber in place with the other hand.

STEP 4:

Install four (4) M4 thumb screws onto your motherboard. It is mandatory to put 0.7mm plastic washer underneath each of the M4 thumb screws. Tighten the screws to the metal backplate until you reach the end of the thread. Using tools (such as pliers) is not recommended.

STEPS:

Install the motherboard back into the computer chassis

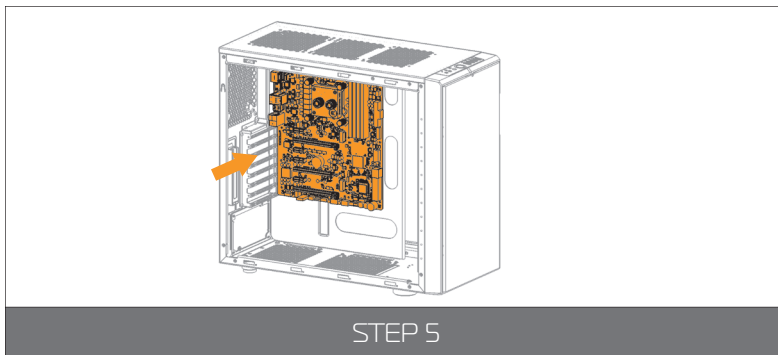

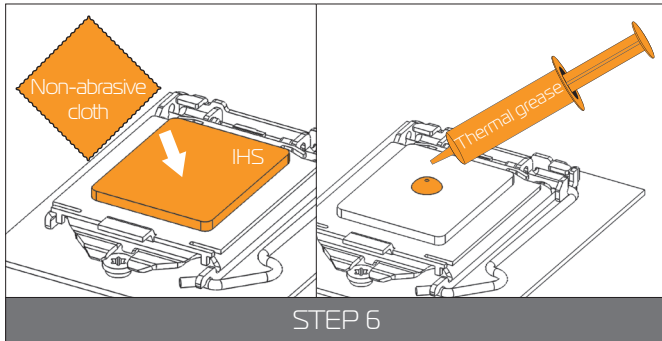

STEP6:

Cleaning the CPU: Wipe the CPU's contact surface (by using non-abrasive cloth or Q-tip, as shown on sample photo).

Applying thermal compound: EK recommends blob or line method of applying the enclosed EK-TIM EctoTherm thermal compound to the CPU heat spreader (IHS) - see sample photo on right.



The quantity of about two rice grains is just about right. There is no need to cover the whole IHS. Applying too much thermal grease will have negative impact on the cooling performance!

STEP 7:

Align the water block over the mounting screws on the LGA-115x motherboard with pre-installed CPU.



Before proceeding with the installation It is mandatory to remove the protective foil from the backside of the water block.

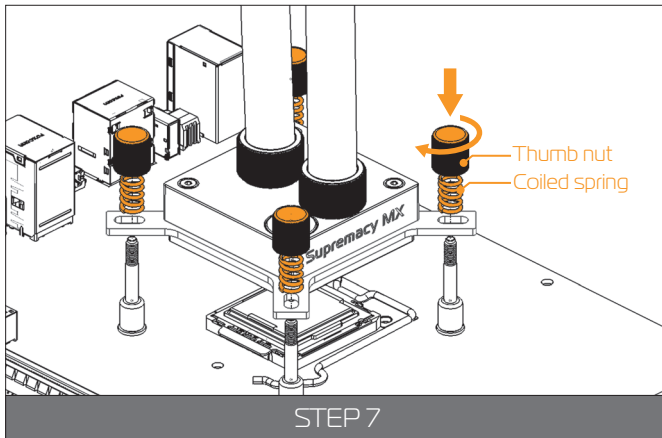

Place an enclosed coiled spring and thumb nut over each M4 thumb screw. Start fastening two thumb nuts at a time, preferably in cross pattern and do not tighten them fully until all of them are partially screwed in. Then - using your fingers only screw in all four thumb nuts until you reach the end of the thread.

Your EK-XLC Predator installation on LGA-115x platform is now complete.



Starting up your computer

Before you add the power to your computer please check if everything is installed according to the installation manual.

Turn on your computer. When turning on the computer check that the temperatures of the CPU are normal. It is best practice to enter BIOS/UEFI and check hardware health monitoring section on initial boot!

POSSIBILITIES OF EXPANDING THE SYSTEM

EK-XLC PREDATOR WITH QUICK-DISCONNECT COUPLINGS (QDC)

The EK-XLC Predator 280 and 360 are capable of expanding with one- (140 variant) and two (280/360 variant) additional water block and one radiator* and/or reservoir.



There is no need to unmount the unit from the chassis unless you face serious tube-routing constraints. Because of the no-spill quick disconnect couplings the expansion is very quick, easy and safe when using QDC-enabled water blocks.

For the expansion you will need:

- A new pre-filled waterblock or radiator

OPTIONAL

Required tools (in case of need to refill the loop):

- 6mm Allen key (usually enclosed with the waterblock)
- ATX Bridging plug

(EAN: 3831109867716)

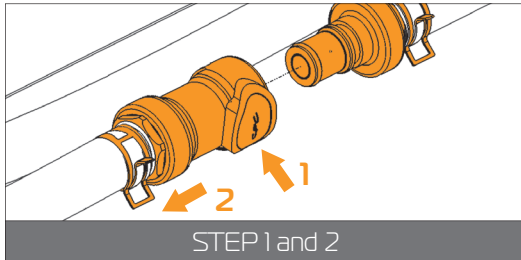
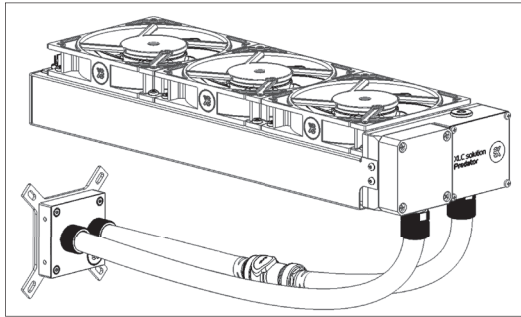

STEP 1 and 2

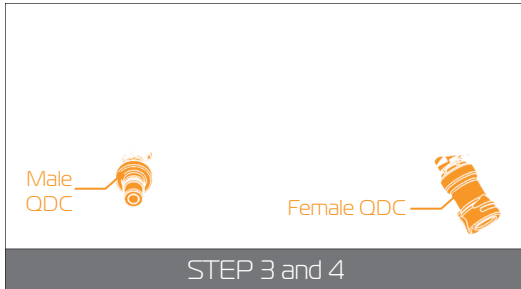

STEP 3 and 4

STEP 1:

Turn off your computer and unplug the computer from power.

STEP 2:

Disconnect the QDC installed on the EK-XLC Predator with QDC. First you need to press on the button on the QDC to release (disconnect) the mechanism which holds it together. After that you should gently pull it apart and you are done.

STEP 3:

Install the QDC enabled pre-filled water block onto your graphics card as per installation manual (which came with the water block) and install it into your PCI-express expansion slot on your computer.

STEP 4:

Route the tubes in the way that the QDC's can be connected with the present ones on the EK-XLC Predator with QDC. Be careful not to make contact with the hardware as the metallic tube clamps can short electrical component. The tubes should be long enough to do so.

* Adding an additional radiator or reservoir requires draining of the Predator unit.

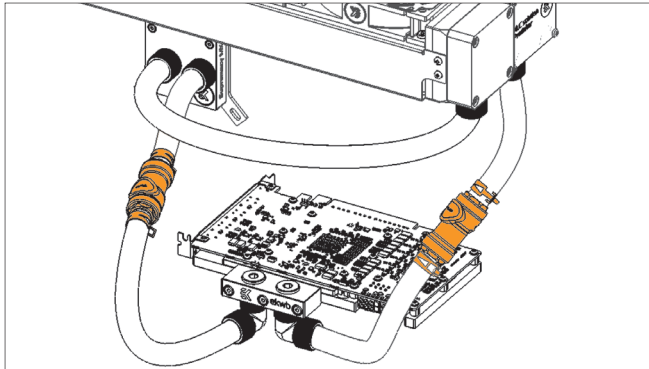

STEP 5

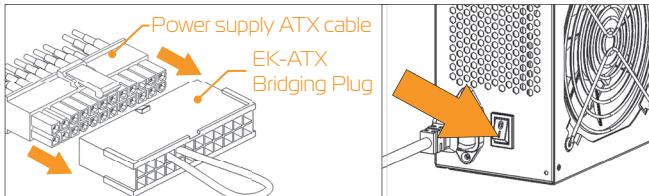

STEP 6 and 7

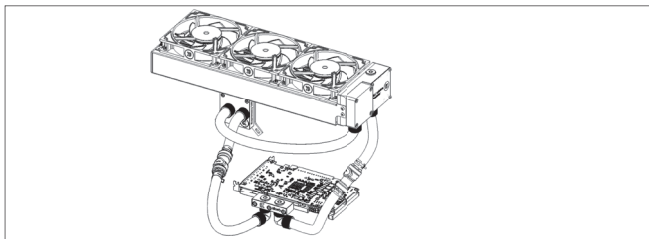

STEP 8

STEP 5:

Connect the ODC couplings according to the sketch on the right. You will feel the locking click sound when assembled correctly. The expansion is now complete.

OPTIONAL

STEP 6:

Plug in the ATX bridging plug. Make sure nothing except the fan splitter hub is plugged to the power supply. You must also unplug the fan and the PWM connectors from the fan splitter hub (Page 9)

STEP 7:

Turn the power supply on and check that only the pump is running.

STEP 8:

It is always a good practice to conduct a 24-hour leak test to ensure the system is leak free and safe to use. Once the test is complete power off the power supply unit and remove the EK-ATX Bridging Plug from the main 24-pin ATX cable.

Upon completing the leak test you can safely reconnect all motherboard-, graphics card- and SATA power cables. Your computer is now ready to use.



Before you add the power to your computer please check if everything is installed according to the installation manual.

STEP 9:

Starting up your computer

Turn on your computer. When turning on the computer check that the temperatures of the CPU are normal. It is best practice to enter BIOS/UEFI and check hardware health monitoring section on initial boot!

POSSIBILITIES OF EXPANDING THE SYSTEM

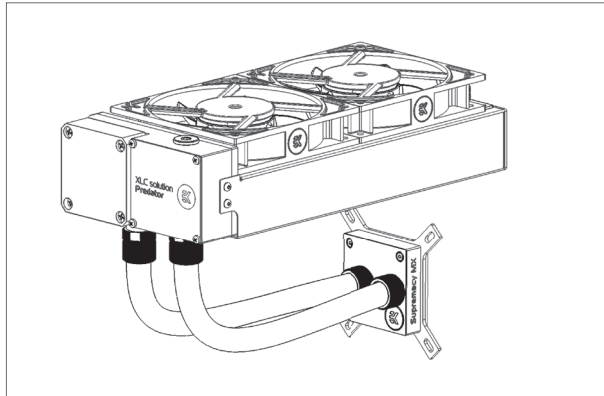

EK-XLC PREDATOR WITHOUT QUICK DISCONNECT COUPLINGS (QDC)

The EK-XLC Predator 140 and 240 are capable of expanding with one (1) additional water block, radiator and reservoir (optional).



YOU MAY NEED TO REMOVE COMPLETE UNIT FROM YOUR COMPUTER CHASSIS!

For the expansion you will need (recommended):

- **A additional waterblock/reservoir**
- **Tubing: EK-Tube ZMT Matte Black 15,9/9,5mm** (EAN: 3830046999207)
- **Fittings: EK-ACF Fitting 10/16mm** (EAN: 3831109846452)
- **Coolant: EK-Ekoolant EVO CLEAR (Premix 1l)** (EAN: 3830046999689)
- **EK-ATX Bridging Plug** (EAN: 3831109867716)

Required tools:

- A pair of scissors (to cut the tube to size)
- 6mm Allen key (usually enclosed with the waterblock)



Before undertaking the following steps it is advised to have a suitable plastic container and some paper towels on hand in order to prevent coolant spillage

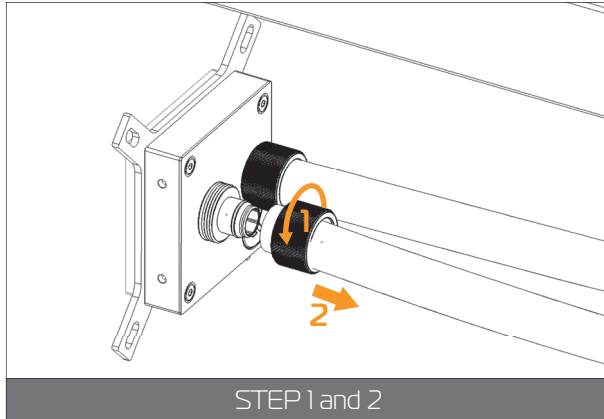

STEP 1 and 2

STEP 1:

We recommend that you drain the loop through the fitting on the CPU waterblock. Unscrew the fitting compression ring in counter-clockwise direction.

STEP 2:

Gently pull the tube off the fitting. Before you do that it is a good practice to put the cup under the tube and fitting for the purpose of safe draining procedure. You can tilt the whole unit to let all the coolant out of the system.

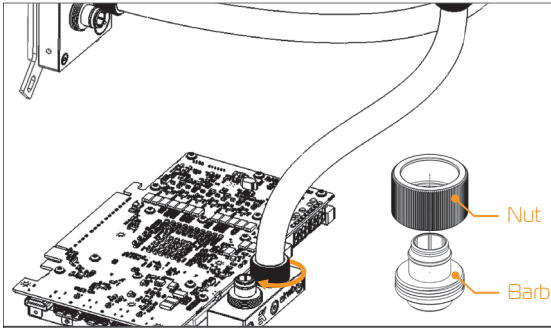

STEP 3 and 4

Take the additional liquid cooling component (water block of any type, radiator...) and mount it according to its installation manual. To connect it to the EK-XLC Predator unit please follow the steps below:

STEP 3:

Connect the loose tube from Predator unit to the 10/16 fitting on the additional water block.

STEP 4:

Make sure that the tube sits firmly on the fitting barb and then tighten the compression ring using your hands only. Do not use any tools (i.e. pliers) during this process.



If the present tube is not long enough you will have to cut a new-longer one.

OPTIONAL

STEP 5:

Measure the length of the tube that is needed to connect the water blocks together. You can use a pair of scissors or a knife to cut the tube.

STEP 6:

Attach the tube onto the both fitting barbs until it sits firmly. Secure the fitting's compression ring to make the assembly complete. Check again that all of the tubing is secured by compression fittings as intended.



STEP 5 and 6



Filling up the system:

Before starting to fill the system you should prepare some paper towels in case of dripping. In order to fill up successfully please follow the steps below.

STEP 7:

Use 6mm Allen key (supplied with every EK water block) to unscrew the plug on the back-side of the Predator unit radiator.

STEP 8:

Start filling process by adding coolant through the port on the back of the unit as shown on the picture on STEP 8. Pour the coolant slowly until the unit is full then shake it a bit to get out as much air as possible. You can alternatively screw the plug in and rotate the unit in multiple directions and then repeat the procedure until there is no air left in the unit.

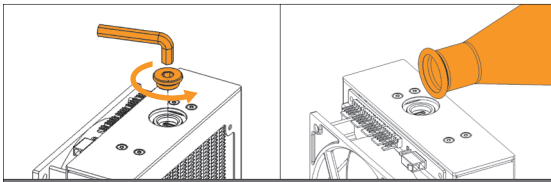

STEP 7 and 8



It is essential to get as much air as possible out of the system at this stage!

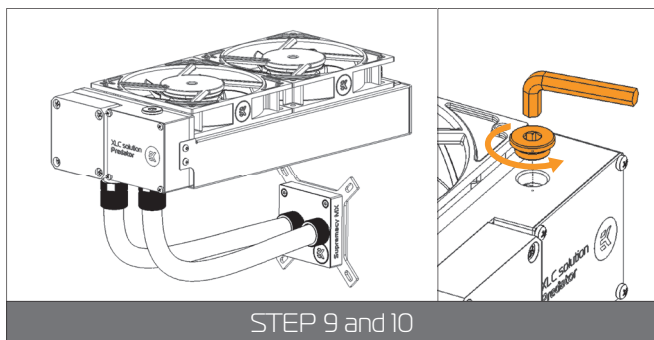

STEP 9 and 10

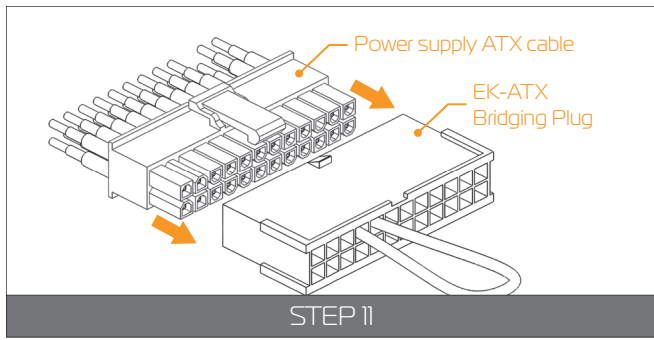

STEP 11

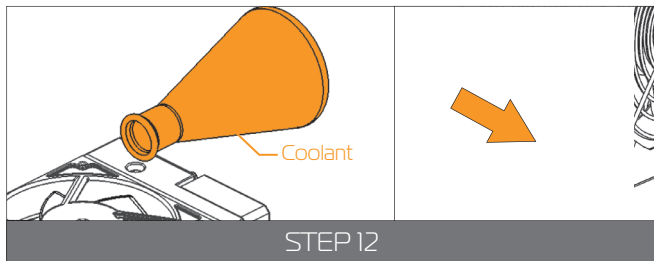

STEP 12

STEP 9:

Reinstall the plug, removed in STEP 7 using 6mm Allen key. Afterwards place the unit on the firm surface with fans facing upwards as pictured in STEP 9 and 10

STEP 10:

Unscrew the integrated reservoir plug in counter-clockwise direction using 6mm Allen key. Add more coolant until the unit seems full.

OPTIONAL

STEP 11:



Plug in the EK-ATX Bridging Plug (EAN 3831109867716) to your male 24-pin ATX PSU cable to jump-start your computer. It is a good practice to also unplug the fans from the fan splitter hub (see page 9).

Make sure nothing except the fan splitter hub is plugged to the power supply. All motherboard-, graphics card- or SATA power should be disconnected!

STEP 12 and 13:

Upon powering up the Predator the coolant level will most likely drop and the unit (namely pump) might operate loudly. This is caused by air still present in the loop. When it does you must add additional coolant until the liquid line is clearly visible and the unit is full.

The air is being bled from the system as the pump is running. The procedure for assisted bleeding air from the system is as following:

- 1) Turn off your computer (or power supply unit)
- 2) Add more coolant to the unit (top it off)
- 3) Turn the power on, let it run for 5 minutes
- 4) Shake and tilt the unit to force the remaining air bubbles out. Reinstall the plug to prevent coolant spillage during this substep.
- 5) Repeat substeps 1 to 4 until the unit is full



Once the rattling diminishes this is a good sign that the loop is free of air. The installation of an additional reservoir greatly simplifies this procedure.

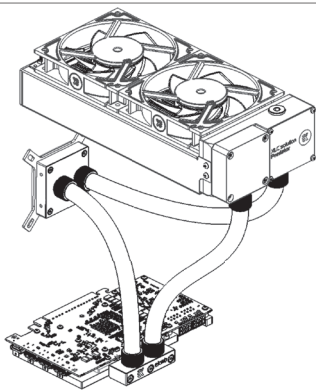

STEP 14

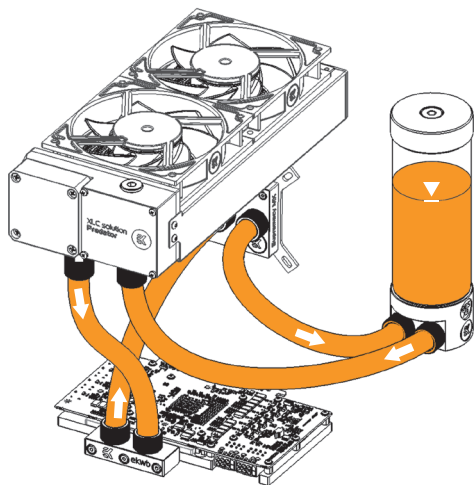

STEP 14:

It is always a good practice to conduct a 24-hour leak test to ensure the system is leak free and safe to use.

Upon completing the leak test please reinstall the liquid cooling unit back into your computer chassis.



Before you add the power to your computer please check if everything is installed according to the installation manual.

STEP 15: Starting up your computer

Turn on your computer. When turning on the computer check that the temperatures of the CPU are normal. It is best practice to enter BIOS/UEFI and check hardware health monitoring section on initial boot!

OPTIONAL

Adding an external reservoir:

In order to make the refilling process of the unit easier after the expansion it is recommended to install an additional external reservoir.



To achieve the best flow balance in the loop it is mandatory to **mount the reservoir on the last stage before the liquid enters into the pump/radiator unit** – as shown on the picture.

It is mandatory to install the reservoir according to its installation manual. In order to connect it to the existing loop you should follow the STEP 1 to STEP 12 in this chapter. You should fill your reservoir between STEP 7 and STEP 8.

It is a good practice to fill your loop at the highest point. In our case that means through the reservoir or through the chamber on the pump/radiator/fan unit (see STEP 8. of this chapter)

In our case we have added a reservoir:
EK-RES X3 250 – EAN (3831109841020)

INSTALLING TRANSPARENT TUBING (OPTIONAL)

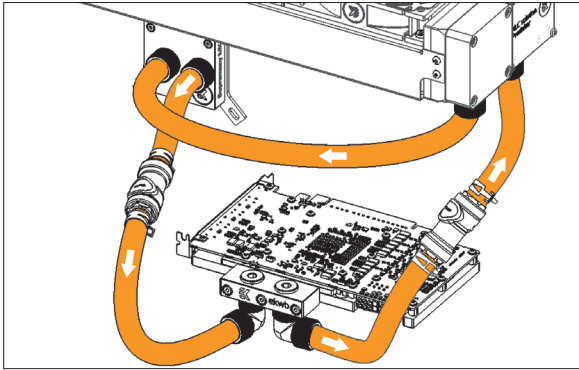

When changing the original EK ZMT tubing for transparent tubing (PrimoChill Primo-Flex™ Advanced LRT™ 9,5 mm (3/8") / 15,9 mm (5/8") - Crystal Clear tube) or equivalent it may happen that the coolant evaporates through the tubing walls due to PVC material being slightly porous.



IMPORTANT: When replacing original EPDM rubber tubing for PVC tubing it is mandatory to check for cooling liquid level on a regular basis. EK highly recommends installing additional external reservoirs when replacing the original tubing.



Modifying the Predator unit by replacing original soft EPDM tubing with solid tubing (i.e. PETG, Acrylic, copper or similar) without using any external reservoir may result in malfunctioning of the unit. Solid tubing does not allow for expansion under thermal load. Under worst case scenario the unit might develop a leak due to increased pressure.

MAINTENANCE

In order to obtain the best performance through whole lifespan of the product it is crucial to follow these maintenance tips:

TIP 1: DUST REMOVAL

It is mandatory to remove the dust every **2-3 months**. EK recommends to use a vacuum cleaner or compressed air to blow the dust away. The most dusty is usually the radiator so pay special attention to that. Do not forget to turn off the computer and unplug the power supply. It is recommended to remove the dust outside.

TIP 2: CHECKING ELECTRICAL COMPONENTS

Once a year you should check the pump and the fans, if they are running as

they should. The pump and fans must run silently without any rattling noises and must react to PWM duty cycle changes. All imperfections may lead to overheating and breakdown.

TIP 3: CLEANING THE UNIT (RELATED TO CHAPTER TROUBLESHOOTING)

Every 3 years the unit should be thoroughly cleaned. You must let all the coolant out (Page 16). The radiator must be flushed and the pump checked and cleaned. It is recommended to change the tubing.

TIP 4: USE EK DESIGNED AND MANUFACTURED PARTS ONLY

It is recommended to use only genuine EK Water Blocks liquid cooling gear, parts and add-ons to prevent any performance, compatibility and warranty issues.

FREQUENTLY ASKED QUESTIONS

Q Is XLC Predator compatible with all desktop LGA-2011(-3) motherboards? How about older LGA-1366 and -755?

A: Yes, due to the use of new mounting mechanism the XLC Predator is fully compatible with all standard LGA-2011-3 motherboards, regardless of whether the motherboard has a hole cut-outs on the circuit board.

It is possible to use the Predator on the older LGA-1366 and LGA-775 type motherboards by purchasing the optional EK-Supremacy EVO Backplate [EAN: 3830046990648]



Q How many water blocks can you add to the loop?

A: The EK-XLC Predator liquid cooling unit can be upgraded with several additional parts. However in order to keep performance at a reasonable level it is recommended not to upgrade EK-XLC Predator with no more than:

- one (1) GPU water block (Predator 140, 240)
- two (2) GPU water blocks (Predator 280, 360)

Additional radiator can also be attached to the Predator loop, however this requires draining of the system. Predator units without QDC couplings are highly recommended to be upgraded with external reservoir when expanded. This allows for easier filling and bleeding process.



NOTE: To achieve the best performance it is highly recommended to run pump at full speed when expanding the Predator unit with additional water blocks. Please consult page 29 of this manual.

Q What flow rates are to be expected with EK-XLC Predator?

A: The Predator units typically operate at about 150L/h (units with QDC) and 185L/h (units without QDC) at full speed respectively.

Installing a typical GPU pre-filled water block with Quick-Disconnect Couplings (QDC) typically drops flow rates from 150L/h to about 120L/h. Adding two such water blocks would result in flow rates of around 100L/h. Not using Quick-Disconnect Coupling on water blocks results in flow rates of about 130L/h in the same scenario.

Flow rates of around 100L/h is considered adequate for efficient cooling of the modern high-power GPUs.



NOTE: To achieve the best performance it is highly recommended to run pump at full speed when expanding the Predator unit with additional water blocks. Please consult page 29 of this manual.

Q Is it possible to flip the fan orientation?

A: Yes, however this requires cutting of the zip-ties holding the cables together. The fans can be removed by the use of enclosed Allen key (2.5mm). When flipping the fan orientation it is crucial to keep the zip-ties in place (which function as a washer as well), otherwise the fan screws might pierce and thus irreparably damage the radiator core.

Such damage is not covered by warranty.

Q Can the Push-Pull Fan configuration be used with EK-XLC Predator?

A: Yes, the Predator can accommodate additional fans on the bottom side and thus work in push-pull regime. Push-pull setups, which include fans, screws as well as splitter cables are available for separate purchase. See www.ekwb.com/shop/aio/ for more details.

Q Is it possible to 'daisy-chain' the integrated PWM splitter?

A: Yes, the integrated PWM splitter allows for daisy-chaining of additional PWM splitter cables, such as EK-Cable Y-Splitter 2-Fan PWM (10cm) [EAN: 3831109867860], as long as the total power draw does not exceed 25W (2A on +12VDC) - the limit of SATA power connector of the Predator unit.

Q What thermal performance is to be expected from the Predator unit?

A: The nominal cooling capacity of the Predator units is listed in the table below:

	dT=10K	dT=15K
Predator 240 *	287W	430W
Predator 360 *	425W	637W
Predator140 **	179W	269W
Predator 280 **	358W	537W

* = Vardar 120 @ 1850rpm

** = Vardar 140 @ 1500rpm

The nominal capacity tells how much heat is the Predator unit able to move with 10°C (10K) or 15°C (15K) increase in liquid temperature over ambient.

Example: Ideally, the Predator 140, cooling an overclocked LGA-1151 Skylake Core i7 CPU (150W) and the NVIDIA GeForce GTX1080 class GPU (225W) would achieve liquid temperatures of about 21°C above ambient during maximum combined (synthetic) workload. Given the ambient temperature of 22°C, this would result in liquid temperature of around 43°C in ideal situation. One can usually expect 10-15°C higher GPU core temperature (GPU 53-58°C).

 The same formula works for majority of hardware as long as the correct TDP value is used.

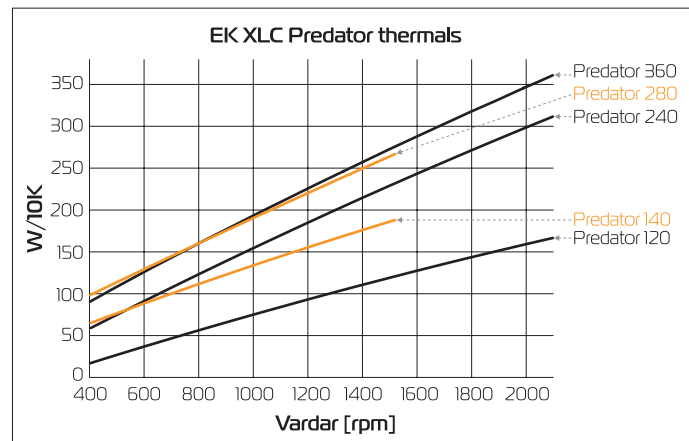

IN CASE OF CPU OVERHEATING:

Very high CPU temperatures are usually the symptoms of malfunctioning liquid cooling loop, assuming the contact between CPU heat spreader and water block itself is good and that the water itself is adequately cooled within the radiator. This can occur either due to:

1. Malfunctioning or non-working water pump: The symptoms usually include rapid spike in temperature when stressing your CPU to the maximum (for example with Prime95 software). Make sure the pump is plugged in to the power connector and that the liquid is indeed flowing in your system. You should feel the pump vibrating in your hand. Observe the flow indicator or flow meter reading if present. »The PWR GOOD LED indicator on the PWM splitter should glow red when working. No light means no power is getting through – please check electrical connections.

2. Malfunctioning or non-working cooling fans: The symptoms usually include rapid spike in temperature when stressing your CPU to the maximum. Make sure the cooling fans are plugged in to the power connector hub and that the blades are indeed rotating. »The PWR GOOD LED indicator on the PWM splitter should glow red when working. No light means no power is getting through – please check electrical connections.

3. Kink in the liquid cooling tubing: Very similar symptoms to both above described. Thin-walled tubing may collapse easily under low radius turns or when obstructed by other computer chassis elements such as closing side panel doors. Check the tubing for any signs of kink which restrict the flow. This is normally not the case when using original tubing.

4. Clogged microchannels in the water block: Clogged microchannels in the water block: microchannels can get clogged easily with various dirt particles and impurities, especially with plasticizer powder which has leached from the tubing (When using unsafe liquid cooling tubing). The

symptoms usually include rapid spike in temperature when stressing your CPU to the maximum, flow rates are very low. Visually inspect the water block internals for any buildup or contamination and clean the system if necessary. In case the water block with translucent acrylic top is employed this inspection can be done without disassembling the system.

5. Thermal interface material (paste/grease) not applied or applied improperly: Lack of - or even too much TIM - may result in CPU overheating. Please refer to STEP 2 in INSTALLING THE WATER BLOCK section.

Another culprit could be partially or completely defective CPU. Some CPUs run at higher temperatures than the others. Overheating of the CPU can also occur due to:

1. Poor thermal contact within the CPU itself: Some CPUs, such as Intel LGA-1151 socket based Skylake, Intel LGA-1150 based Haswell and older, socket LGA-1155 based Ivy Bridge are notorious for their poor thermal contact between the CPU die and the heat spreader (IHS) itself due to the use of poor TIM. This is the problem of the processor and not the Predator CPU liquid cooling unit. These CPUs are known to run very hot (80°C+) even on factory set frequencies. For best performance it is usually recommended to replace the TIM between the die and the IHS or to even run the processor de-lidded. Both require hazardous IHS removal which voids processor's warranty but can lead to temperature decrease of 30°C and higher.



EKWB deems der8auer Delid Die Mate tool safe to be used by experts for de-lidding of the Intel Skylake CPUs.



Upon exhausting all options please consult EK knowledge base at <http://support.ekwb.com> . Raise a question through EK Support ticketing system if needed.

THE COOLER IS TOO LOUD:

The Predator unit is equipped with fast-spinning EK-Vardar high-static pressure PWM controlled fans, which run at very high speed if the UEFI/BIOS is not set to control fan speed. Make sure to set control mode to PWM (instead of DC)! On majority of motherboards this feature can be found in 'Hardware Monitoring' section of the UEFI/BIOS. Please consult your motherboard manual on how change fan speed.

General ASUS Z170/X99 motherboard guide:

1. Enter UEFI and go to QFAN Control
2. Select the FAN header you wish to edit (the one that you have connected the Predator's PWM cable to)
3. Select PWM mode (instead of DC)

General ASRock Z170/X99 motherboard guide:

1. Enter UEFI and go to H/W Monitor
2. Choose the FAN header you wish to edit (the one that you have connected the Predator's PWM cable to)
3. Change from 'Full Speed' to 'Silent', 'Standard' or 'Performance' mode

General Gigabyte Z170/X99 motherboard guide:

1. Enter UEFI and go to M.I.T. -> PC Health Status
2. Select (CPU Fan) Speed Control optionbox and select 'Auto', 'Normal' or 'Manual'.

General MSI Z170/X99 motherboard guide:

1. Enter UEFI and go to Hardware Monitor
2. Select the FAN header you wish to edit (the one that you have connected the Predator's PWM cable to)
3. Enable Smart Fan Mode Checkbox
4. Change ramp-up curve by dragging and dropping 4 coloured squares



Make sure the 4-pin PWM Fan connector is indeed plugged in correctly into the appropriate FAN header on your motherboard. Please consult page 9, chapter Connecting the hub to the motherboard.

GENERAL LIQUID COOLING PARTS CLEANING GUIDE



Liquid cooling parts may be disassembled for cleaning purposes on an occasional basis. Your warranty is not voided on disassembly of the water block but the customer loses the EK leak-free guarantee which comes with a factory tested Component. And old, but soft toothbrush is an excellent cleaning tool!

1. Cleaning bare copper: When cleaning bare copper it is recommended to use slightly acidic cleaning agents which include the following organic agents:

- (white) vinegar (acetic acid up to 5-10%)
- lemon juice (citric acid up to 5-10%)

Certain food can also be used for cleaning copper:

- cola (contains phosphorous- and citric acid)
- ketchup or tomato extract (contains acetic- and citric acid)
- mustard (contains acetic acid)



5% vinegar, diluted with 95% water is enough to kill 99.9% of algae and bacteria that could be present on copper in an unmaintained cooling loop as well.

Upon cleaning it is necessary to flush the water blocks in water and rinse them

with distilled water. After rinsing we recommend soaking the water blocks in paper towels until completely dry. It is nearly impossible to avoid the naturally occurring copper tarnishing (oxidation) as the oxidation will reoccur the moment the copper is cleaned of the all oxides.

2. Cleaning nickel plated copper: When cleaning nickel plated copper it is forbidden to use any aggressive chemicals (neither vinegar) or rough materials as you may damage the plating and thus void the warranty. Please note also that due to presence of dye additives and other chemicals the nickel layer may also become discolored/stained over time period. However the staining is normally reversible by simple flush and rinse. Cleaning the nickel plated copper should consists of these steps:

- flush the nickel plated copper under warm water
- clean the surface using wet non-abrasive cloth and rinse with clean water
- polish the hardened deposits (such as algae or dirt) from the nickel plated copper if necessary.

EK recommends the use of automotive soft, non-abrasive metal polish cremes. After you finish using other cleaning methods, give the nickel plating a good polish with a non-abrasive metal or chrome polish. Apply a small amount of polish to a cloth or to the surface of the nickel. Wipe the entire surface of the nickel with the polish, using small circular motions, until it looks shiny and clean. Use another clean cloth to remove the remains of the polishing paste from the surface. Always rinse with distilled water after you are done with polishing.

3. Cleaning acrylic (plexi) glass tops:



Acrylic will fail prematurely if subjected to even small amounts of alcohol, acetone or other aggressive chemicals.

Please do not use anything but warm, soapy water and a toothbrush to clean the acrylic (plexi) glass water block tops and reservoir tubes. Using aggressive chemicals will surely void your warranty!



Algae- or dirt deposits may be rubbed out using soft cloth in combination with warm, soapy water. Rinse with distilled water after cleaning.

4. Cleaning POM (acetal) tops: POM (polyoxymethylene) or Acetal can withstand chemicals such as alcohol or acetone but EK recommend to use these very sparingly as the drying chemicals will surely leave some residue. Usually the POM can be cleaned easily just be the use of soft cloth and warm, soapy water - without the use of any chemicals. Rinse with distilled water after cleaning.

PREVENTIVE STEPS:

1. Using corrosion inhibiting coolant (such as EK-Ekoolant or other market proven coolant) is highly recommended for any water cooling loops. Since EK-Ekoolant is also a surfactant is will prevent algae growth and dirt deposition on all wetted surface.

2. Refrain from using Copper Sulphate based additives in your loop in order to prevent tarnishing on your water cooling gear internals!

PUMP

	Xylem DDC 3.1 MX	EK-SPC 60A
Pump Type	DC centrifugal Pump	DC centrifugal Pump
Bearing Type	Ceramic Bearing Ball	Ceramic Bearing Ball
Rated Voltage	12 VDC	12 VDC
Operating voltage	8*-13,2 VDC *9v starting	8*-13,2 VDC *9v starting
Pump RPM	3000 RPM	2500 RPM
Dimensions (LxWxH)	61x60x21 mm	61,5x61,5x17,5 mm
Life Expectancy	>50 000 h	>50 000 h
Max head of pump	1,6 m	1,9 m

Operating environment

Ambient temperature.....10-50°C

Fluid temperature(coolant).....10-60°C

FITTINGS

Fittings

Type.....2x Compression
 Type.....2x Rotary Compression
 Compatible tubing (metric).....9,5 mm / 15,9mm (ID/OD)
 Compatible tubing (imperial).....3/8" - 5/8" (ID/OD)
 Thread size.....G1/4"
 Material.....Brass
 Coating.....Nickel



DISASSEMBLY OF ROTARY COMPRESSION FITTINGS:

In order to disassemble the Rotary Compression Fitting successfully, namely compression ring from the barb, it is mandatory to use 9 mm Allen key (not enclosed) and lock the barb from the inside. Locking the barb allows for easy unscrewing of the ring.

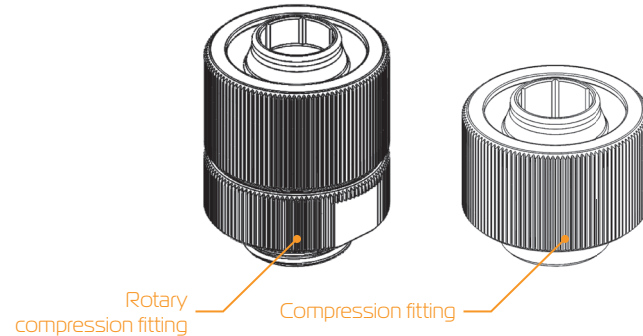
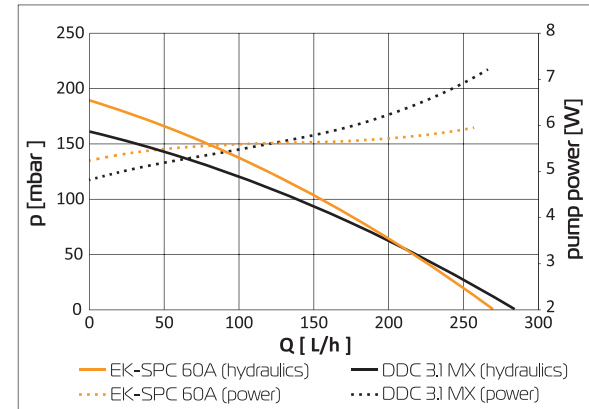

FAN SPLITTER HUB

All the elements that need electricity to run are connected to the **fan splitter hub**, located on the back of the unit.



This fan splitter hub contains three 4-pin PWM Fan headers for three fans and one pump.

A two-pin header is used to connect Predator unit to motherboard CPU Fan header in order to allow for speed regulation of fans and pump. 2-pin PCI-express miniFIT power header is used to provide power to Predator unit.

General characteristics:

- 3x 4-pin PWM fan header (Molex KK 254 standard)
- 1x 4-pin PWM pump header (Molex KK 254 standard)
- 1x 2-pin tachometer/PWM header (Molex KK 254 standard)
- 1x 2-pin power header (Molex miniFIT standard)
- 1x Power LED indicator diode (red)
- Rectified PWM input
- Uniform PWM control on all headers

Connecting the pump directly to motherboard fan header (OPTIONAL)

If you want to control the speed of the pump and the fans separately you should follow the steps below:

STEP 1:

Disconnect the pump's cable from the fan splitter hub. You will need to remove cable ties in order to do so.

STEP 2:

Connect the pump's connector to the CPU fan header (preferably) on the motherboard.

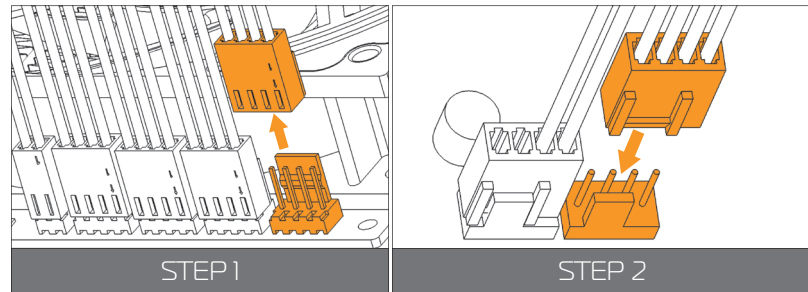
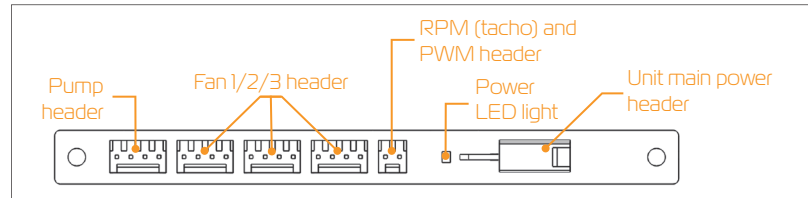
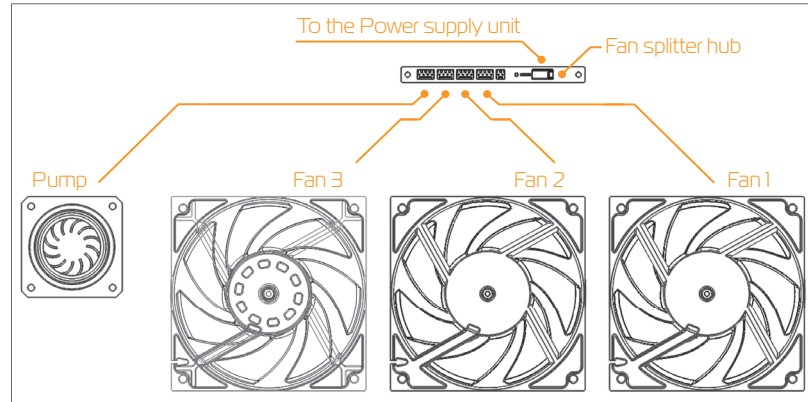

FANS

	EK-Vardar F4-120	EK-Vardar F2-140
Fan type	PWM	PWM
Rated Voltage	12 VDC	12 VDC
Power Draw	2,16W	1,57 W
Max Air Flow	77 CFM = 131 m ³ /h	84 CFM = 143 m ³ /h
Static Pressure	3,16mm H2O = 31 Pa	1,90 mm H2O = 18,6 Pa
Noise Level	33,5 dBA	31,6 dBA
Max speed	2200 rpm (+/- 10%)	1600 rpm (+/- 10%)
Life Expectancy	50.000 hrs @ 40°C (MTBF)	50.000 hrs @ 40°C (MTBF)
Dimensions	120 x 120 x 25 mm	140 x 140 x 25 mm

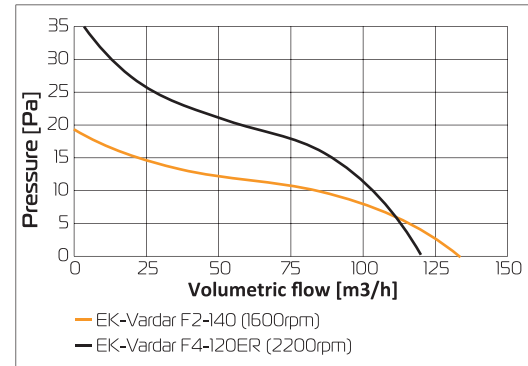

THERMAL GREASE

EK-TIM Ectotherm

Type.....Low Viscosity
 Electrically conductive.....No
 Optimal working temperature.....+100 to -50(°C)
 Thermal conductivity.....8,5 W/mK
 Density.....3 g/cm³

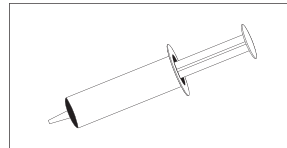

Purchase spare thermal grease here:



TUBING

EK-Tube ZMT Matte Black 15,9/9,5mm

Material.....EPDM
 Color.....Black, not UV-reactive
 Operating temperature range.....-30°C to 110°C
 Dimensions.....9,5 mm / 15,9 mm (ID/OD)

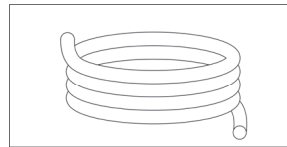

Purchase spare tubing here:







SUPPORT AND SERVICE

For assistance please contact:
<http://support.ekwb.com/>

EKWB d.o.o.
Pod lipami 18
1218 Komenda
Slovenia - EU

SOCIAL MEDIA

-  EKWaterBlocks
-  @EKWaterBlocks
-  ekwaterblocks
-  EKWBofficial
-  ekwaterblocks

