

## Dear EKWB customer - Congratulations!

We would like to congratulate you on choosing EK liquid cooling KIT. You have chosen liquid cooling KIT which performance tops the market compared to other similar size products.

EK liquid cooling kit will make your computer **cooler, quieter** and possibly **faster** if you decide to overclock it.

Before installing make sure you check compatibilities of your hardware at [www.coolingconfigurator.com](http://www.coolingconfigurator.com).

Please check at [www.ekwb.com/shop/kits-cases.html](http://www.ekwb.com/shop/kits-cases.html) for updated manuals (also in other languages).

## RMA Statement:

This product is intended to be installed by expert users only. Please consult with a qualified technician for installation. Improper installation may result in damage to your equipment. EK Water Blocks assumes no liability whatsoever, expressed or implied, for the use of these products, nor their installation. The following instructions are subject to change without prior notice. Please visit our web site at [www.ekwaterblocks.com](http://www.ekwaterblocks.com) for updates or contact our support.

### VERY IMPORTANT NOTICE AND DISCLAIMERS:

While all efforts have been made to provide the most comprehensive installation tutorial possible, EKWB assumes no liability expressed or implied for any consequential damage(s) occurring to your equipment as a result of using EKWB cooling products, either due to errors or omissions on our part in the enclosed instructions, or due to failure or defect in the EKWB cooling products.

### WARRANTY:

Our products are warranted against defects in materials or Workmanship, for a period of 24 months beginning from the date of delivery to the end user. During this period, products will be repaired or have parts replaced at our discretion provided that:

1. the product is returned to the agent from whom it was purchased;
2. the product has been purchased by an end user and has not used for commercial purposes;
3. the product has not been misused, handled carelessly, or used in a manner other than in accordance with the instructions provided of which-describe the proper installation of our product.

This warranty does not confer rights other than those expressly set out above and does not cover any claims for consequential loss or damage. This warranty is offered as an extra benefit and does not affect your statutory rights as a consumer. This warranty is voided if the product comes in contact with aggressive additives or any kind of alcohol or alcoholic derivate that have rendered the products useless.

### OTHER INSTRUCTIONS:

Please note that EKWB holds no responsibility of any kind if assembly is not made by instructions. This applies also for all products that are not listed as compatible on web page. Users must by all means also consider instructions that are being made for proper use of pump and other water cooling components provided by manufacturer(s). HINT: Never let your pump dry running. If that happens for prolonged period of time you risk destroying pump's bearing and rendering pump useless.

## TABLE OF CONTENTS/INSTALLATION STEPS:

PAGE



EK strongly suggest the following installation steps. Failure to comply may result in leaks and damaged components.

<b>Components &amp; Required Tools check</b>	<b>1</b>
<b>Things you have to know before installing the water cooling KIT</b>	<b>2</b>
<b>1. Preparing and Installing the CPU water block</b>	<b>3</b>
- General information on product	3
- Installing alternative mounting plate and replacing jet plate	3
- Preparing backplate rubber gasket	4
- Preparing CPU and applying TIM	4
- Fastening the CPU water block on to a Motherboard	4
- Connecting the waterblock to the cooling circuit	4
<b>2. Preparing the PC case</b>	<b>5</b>
<b>3. Installing the radiator with fans</b>	<b>5</b>
<b>4. Installing the Pump/Reservoir Unit</b>	<b>6</b>
<b>5. Installing the Tubing</b>	<b>6</b>
<b>6. Connecting the PUMP and FANS and filling up the system</b>	<b>7</b>
	<b>24our leak testing</b>
<b>7. Emptying the water-cooling system</b>	<b>9</b>

## ENCLOSED EQUIPEMENT

		
EN   Box	EN   CPU Water Block with AMD plate	EN   CPU Backplate mechanism
		
EN   Thermal compound - grease	EN   Radiator	EN   Fans
		
EN   Pump/reservoir combo	EN   Pump/reservoir holder	EN   LED lights
		
EN   Compression fittings	EN   CPU mounting mechanism	EN   Coolant
		
EN   Tube	EN   ATX Bridging Plug	EN   Fan cable Y-splitter

## REQUIRED TOOLS / BENÖTIGES WERKZEUG

	
EN   1L bottle of distilled water	EN   Needed hardware for installation

## THINGS YOU HAVE TO KNOW BEFORE INSTALLING WATER COOLING KIT

### WATER COOLING SYSTEM

1. In order to lower shipping costs we have decided to enclose only the coolant concentrate for liquid cooling. Therefore you need to provide 1 litre (1L) of distilled water. You can get it at every gas station or supermarket.
2. Never run your water cooling KIT solely on tap water!
3. Never use alcohol, alcohol derivatives or alcohol based solvents in the system. Using alcohol might result in permanent damage to water cooling KIT components, especially acrylic parts of the system.
4. Reservoir must be positioned above the height level of the water pump in order for liquid to flood the pump which is crucial for the first start-up.
5. Generally, for optimal performance, the Reservoir must be positioned before the pump in the water loop.
6. Generally, for optimal performance, the CPU water block should be right after the Radiator in the water loop.
7. Generally, for optimal performance, the Pump should be positioned before the Radiator in the water loop.
8. Never run your computer for the first time before 24 hour leak test.
9. If you spot any leaks, turn off the power immediately!
10. Optimize tubing length in order to prevent excessive bending and kinking of the tubing.
11. Never let your pump run dry. If this is happening for a prolonged period of time you may risk destroying water pump's bearing, rendering the pump useless.
12. You are encouraged to periodically clean the radiator assembly as it will collect dust over time. This is best done with soft wide tip brush and vacuum cleaner.

### WATER COOLING SYSTEM

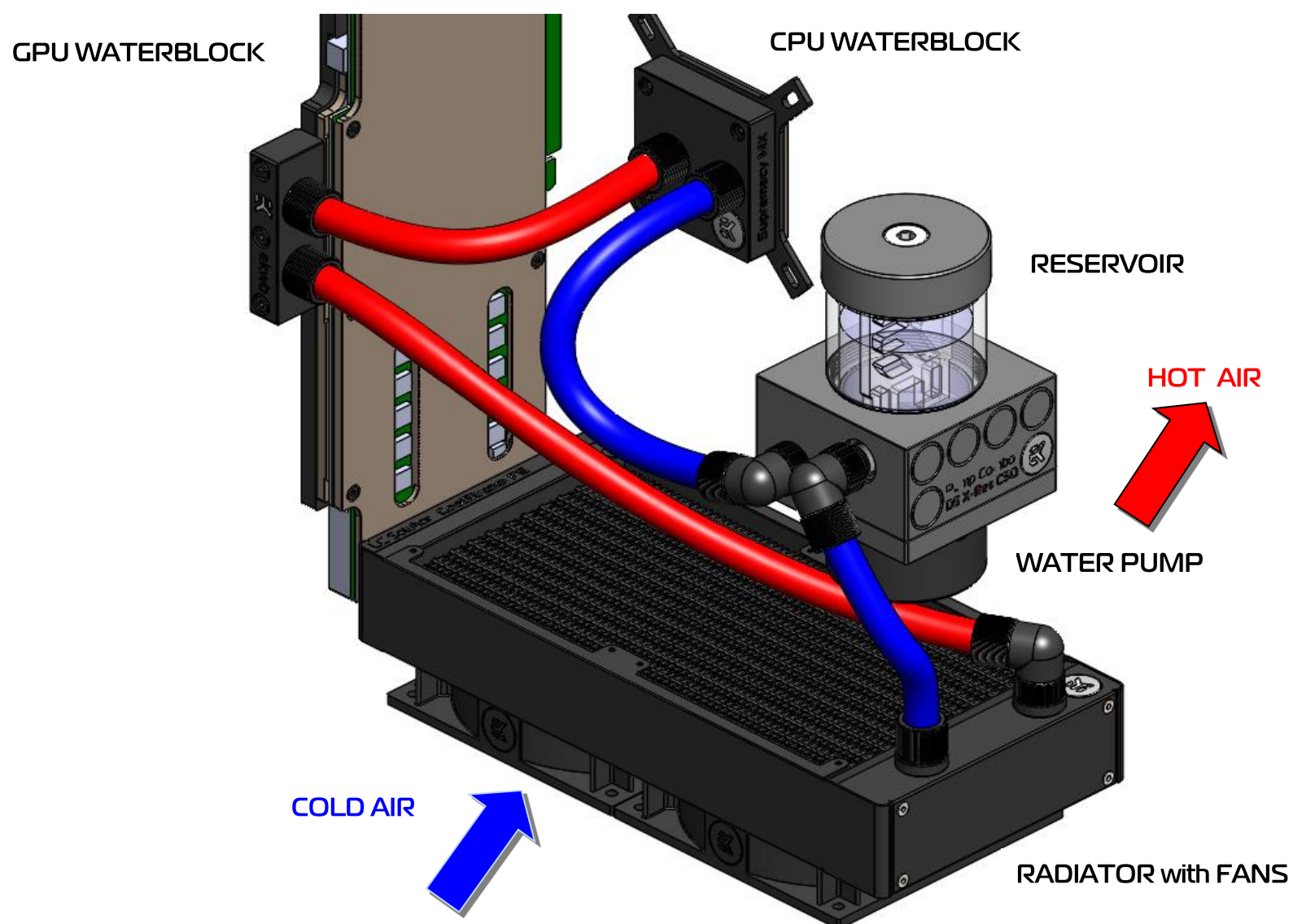



# 1. PREPARING AND INSTALLING THE CPU WATER BLOCK

This product is intended for installation only by expert users. Please consult with a qualified technician for installation. Improper installation may result in damage to your equipment. EK Water Blocks assumes no liability whatsoever, expressed or implied, for the use of these products, nor their installation. The following instructions are subject to change without notice. Please visit our web site at [www.ekwb.com](http://www.ekwb.com) for updates. Before installation of this product please read important notice, disclosure and warranty conditions printed on the back of the box.

Before you start using this product please follow these basic guidelines:

1. **Please carefully read the manual before through before beginning with the installation process!**
2. **Please remove your motherboard from the computer to assure safest mounting process in order to prevent any possible damages to your CPU and/or motherboard's circuit board (PCB).**
3. **The EK-HFB, EK-HDC and EK-ACF type fittings require only a small amount of force to screw them firmly in place as the liquid seal is ensured by the rubber o-ring gaskets.**
4. **The use of corrosion inhibiting coolants is always recommended for any liquid cooling system.**

## STEP 1: GENERAL INFORMATION ON PRODUCT

Congratulations on your purchase of EK-Supremacy MX UNI CPU water block. This water block is pre-assembled for use with modern Intel desktop socket type motherboards. By default this water block supports the following CPU sockets:

- Intel socket LGA-115x and LGA-2011(-3)

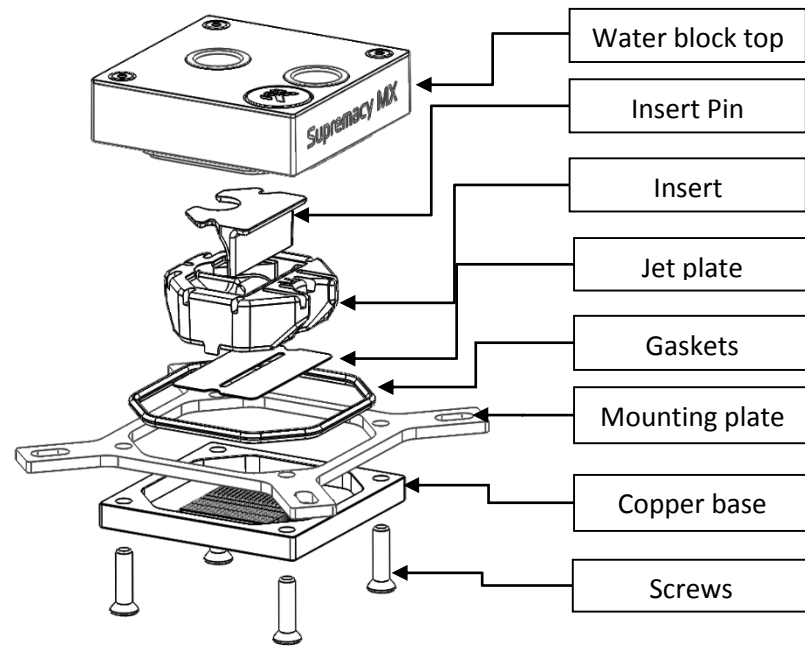

### Caution:

Narrow server type LGA-2011 is **not supported by default** – a **Mounting plate Supremacy LGA-2011 Narrow ILM** (EAN: 3830046990600) is mandatory to install this water block on narrow server type LGA-2011 motherboards.

## STEP 2: TABLE OF CONTENT

The following items are enclosed with each EK-Supremacy MX water block:

- EK-Supremacy MX universal CPU water block /w pre-installed Insert I2 and Jet J1 (0.25mm) (all around great performer)
- **PreciseMount EVO** universal CPU mounting mechanism:
  - o M4 threaded thumb screws (4 pcs)
  - o LGA-2011 M4 threaded mounting studs (4 pcs)
  - o Springs (4 pcs)
  - o M4 threaded thumb nuts (4 pcs)
  - o Washers (4 pcs)
- AMD mounting plate
- EK-Supremacy Backplate
  - o Backplate rubber gasket
  - o Backplate for Intel LGA-1366 and AMD socket motherboards
  - o Backplate for Intel LGA-115x socket motherboards
- Allen (hex) key 2.5mm
- Additional Inserts and Jet plates:
  - o Jet J1 (0.3mm thick)
  - o Jet J3 (0.1mm thick)
  - o Insert I2

Optimal configuration(see table):

Socket	Optimal Insert	Optimal Jet
AMD AMx / FMx	I2	J2
LGA-775	I1	J2
LGA-115x	I1	J2
LGA-1366	I1	J1
LGA-2011	I1	J1
LGA-2011-V3	I2	J3

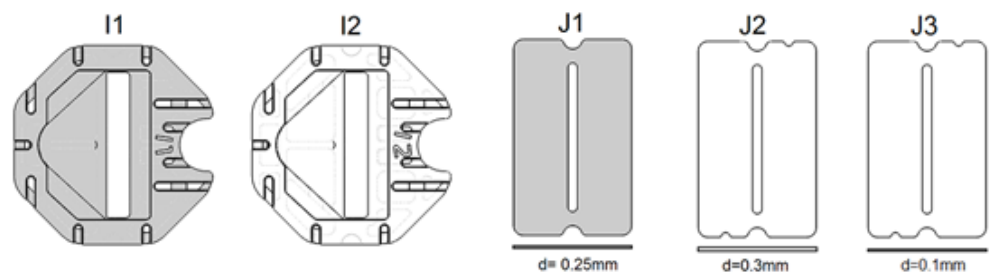

## STEP 4 (optional): INSTALLING ALTERNATIVE MOUNTING PLATE AND REPLACING JET PLATE / INSERT PROCEDURE

1) Place water block on an even surface and remove four M4x16 DIN7991 screws attaching the top to the copper base using the 2.5mm Allen key (not enclosed).

### 2) Replacing mounting plate:

- 2.1) Replace the Intel mounting plate with alternative one. You will feel the mounting plate locking into the position when placed correctly on to the top.
- 2.2) Reseat the larger o-ring gasket (57x2 mm) into the gap between the mounting plate and water block top.

### 3) Replacing jet plate (OPTIONAL):

3.1) Remove the default Jet J1 (0.25mm thick) and replace it with Jet J2 (0.3mm) or Jet J3 (0.1mm), depending on your CPU platform. You will feel the jet plate locking into the position when placed correctly to the water block Insert.

### 4) Replacing insert (OPTIONAL):

4.1) Remove the default Insert I2 and replace it with Insert I1, depending on your CPU platform. It is mandatory to install the Insert Pin and Insert in correct way, there is only one way to install it. You will feel the Insert assembly locking into the position when placed correctly to the water block.

5) Carefully place copper base to waterblock top assembly, make sure gaskets stay in place! **Beware of copper base orientation!**

6) Repeat step #5 if necessary. Screw in all four (4) M4x16 DIN7991 screws using the 2.5mm Allen (hex) key.

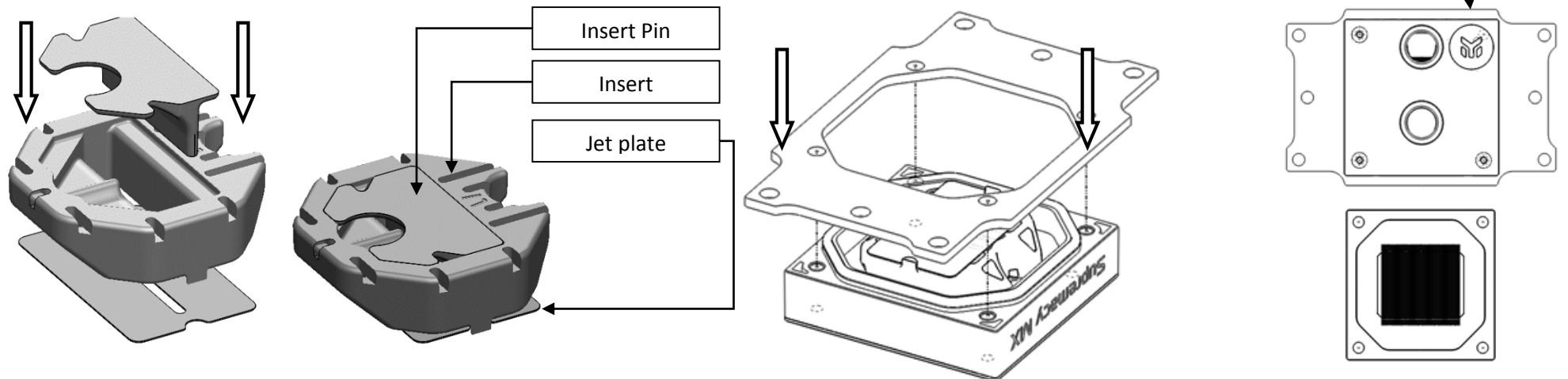

## STEP 4: PREPARING BACKPLATE RUBBER GASKET (FOR INTEL LGA-2011 SKIP THIS STEP)

The enclosed rubber gasket is essential part of the backplate and mounting system and must be used every time you install this water block on any motherboard apart from LGA-2011(-3) socket type. The rubber backplate has a partially cut inner part which needs to be removed when installed on Intel LGA-115x and LGA-1366 motherboard. The rubber is held on four places and can be peeled away with hand. These two pieces can be reassembled later if needed.

### Intel LGA-115x and LGA-1366 socket:

Remove the inner core of the rubber and use the outer part only.

### AMD sockets:

Use the whole rubber backplate including the inner core.

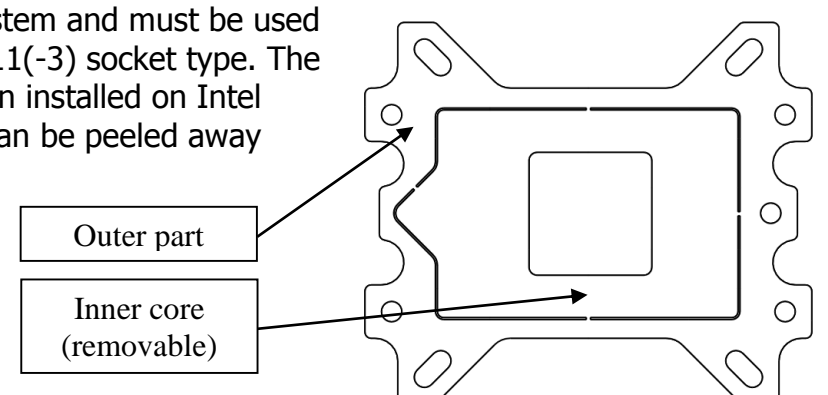



## STEP 5: INSTALLING THE WATER BLOCK:

### STEP 5a: Intel LGA-775/1366 and AMD socket motherboard:

- 1) Place motherboard on an even surface with front facing down.
- 2) Install backplate rubber gasket - depending on your CPU platform (see STEP 4) - and place metal backplate for Intel LGA-1366 and AMD socket to the back of your motherboard **RIBBED SIDE UP!** Align the holes on the motherboard with holes on rubber gasket and backplate.
- 3) Carefully rotate motherboard assembly with front side facing up with one hand while holding the backplate and rubber in place with the other hand.
- 4) Install the rest of mounting system as per installation manual (see STEP 6).

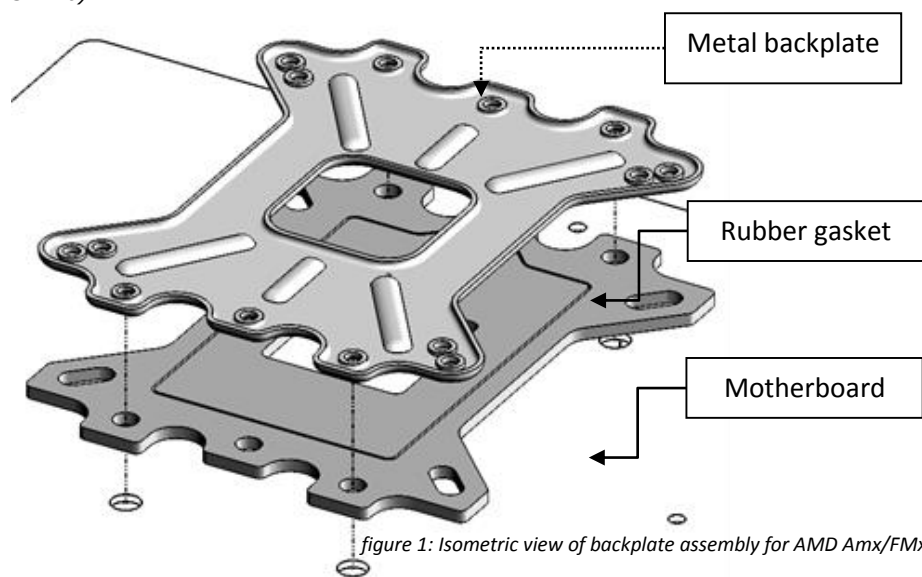

### STEP 5b: Intel LGA-115x socket motherboard:

- 1) Place motherboard on an even surface with front facing down.
- 2) Install backplate rubber gasket depending on your CPU platform (see STEP 4) - and place metal backplate for Intel LGA-115x socket to the back of your motherboard **RIBBED SIDE UP!** Align the holes on the motherboard with holes on rubber gasket and backplate. **Make sure to orientate the rubber gasket to fit past the CPU socket ILM backplate.**
- 3) Carefully rotate motherboard assembly with front side facing up with one hand while holding the backplate and rubber in place with the other hand.
- 4) Install the rest of mounting system as per installation manual (see STEP 6).

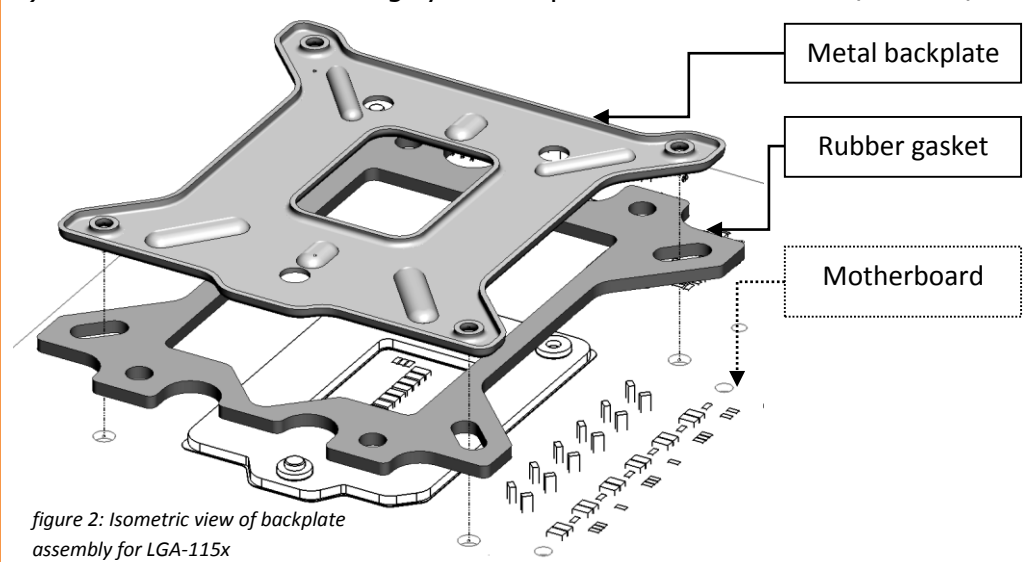

### STEP 5c: Installing the mounting system:

#### Intel Socket LGA-775/115x/1366 and AMD sockets:

Install the M4 thumb screws of the PreciseMount mounting system onto your motherboard. It is mandatory to put 0.7mm plastic washer underneath each of the M4 thumb screws. Tighten the M4 thumb screw to the metal backplate with your hands until you reach the end of the thread. Using tools (such as pliers) is not recommended

#### Intel Socket LGA-2011(-3):

Install four (4) specific LGA-2011 M4 thumb screws into four M4 threaded stubs on the LGA-2011 socket integrated latch mechanism (ILM). The screws are to be installed using no tools (i.e. pliers).

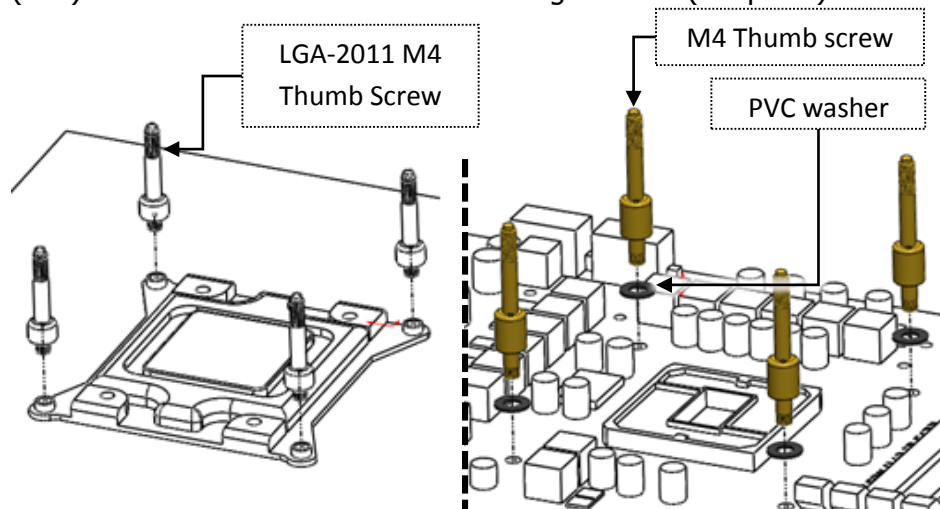

### STEP 5d: Preparing your CPU and applying TIM:

**Cleaning the CPU:** Once mounting mechanism is attached install the CPU into the socket. Wipe the CPU's contact surface (by using non-abrasive cloth or *Q-tip*, as shown on sample photo).

**Applying thermal compound:** EK recommends blob or line method of applying the enclosed Gelid GC-Extreme™ thermal compound to the CPU heatspreader (IHS) - see sample photo on right. The quantity of about two rice grains is just about right. There is no need to cover the whole IHS. Applying too much thermal grease will have negative impact on the cooling performance!

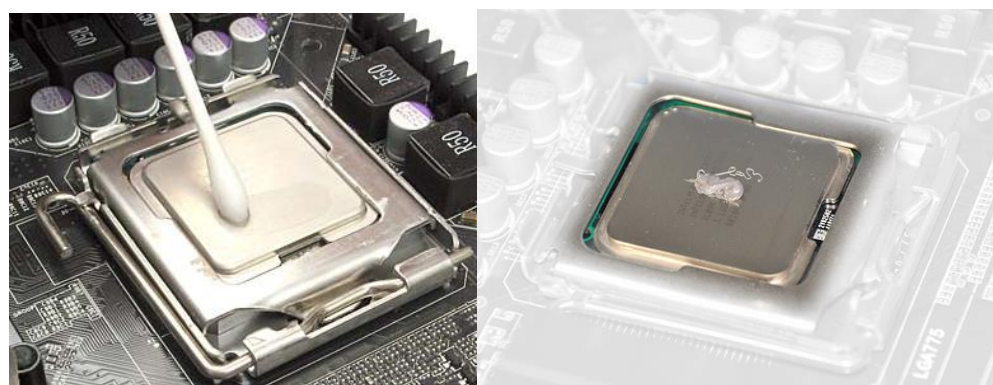

### STEP 5e: Fastening the waterblock:

Install the waterblock on your CPU. Place an enclosed compression spring and thumb nut over each M4 thumb screw. Start fastening two thumb nuts at a time, preferably in cross pattern and do not tighten them fully until all of them are partially screwed in. Then - using your fingers only screw in all four thumb nuts until you reach the end of the thread.

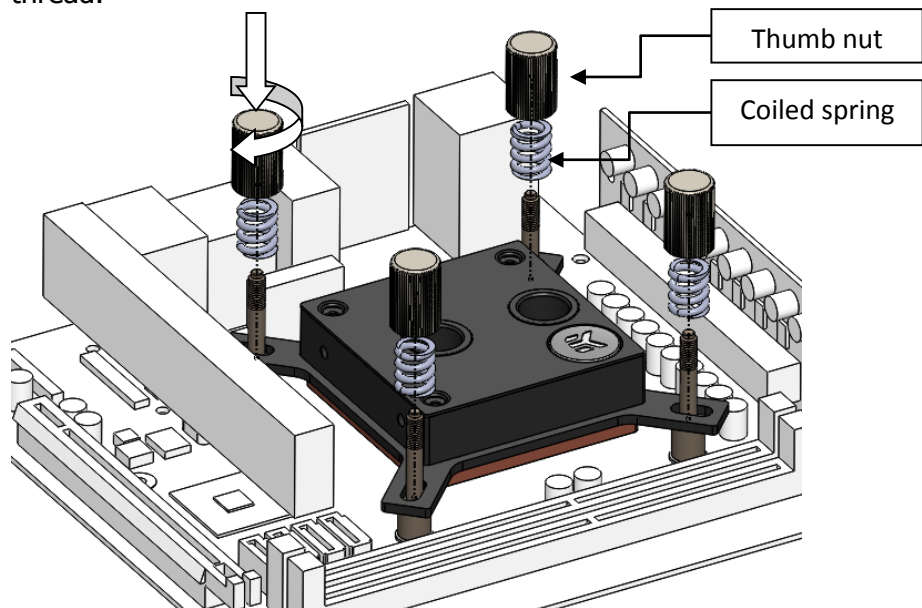

## STEP 6: CONNECTING WATER BLOCK TO THE COOLING CIRCUIT

Carefully identify the direction of the flow in your circuit. For the EK-Supremacy MX series water block to operate properly the G1/4 port nearest to the center of the water block **MUST BE USED AS THE INLET PORT.** EK recommends the use of EK-ACF Fittings. When using fittings other than EK-ACF series please use hose clamps or appropriate substitute to secure the tubing to the barb. The use of biocide containing and corrosion inhibiting coolant is always recommended for any liquid cooling system.

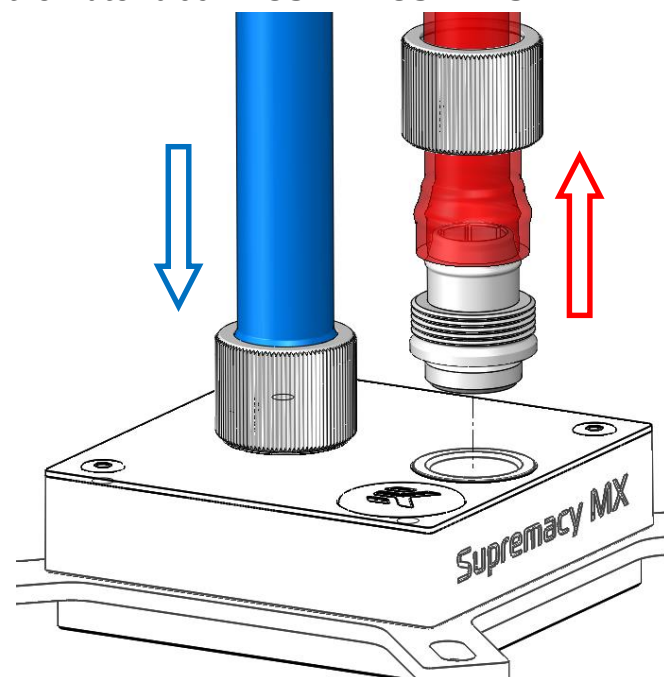

### REQUIRED TOOLS:

- Allen key 2.5mm (enclosed)



## 2. PREPARING YOUR COMPUTER CHASSIS

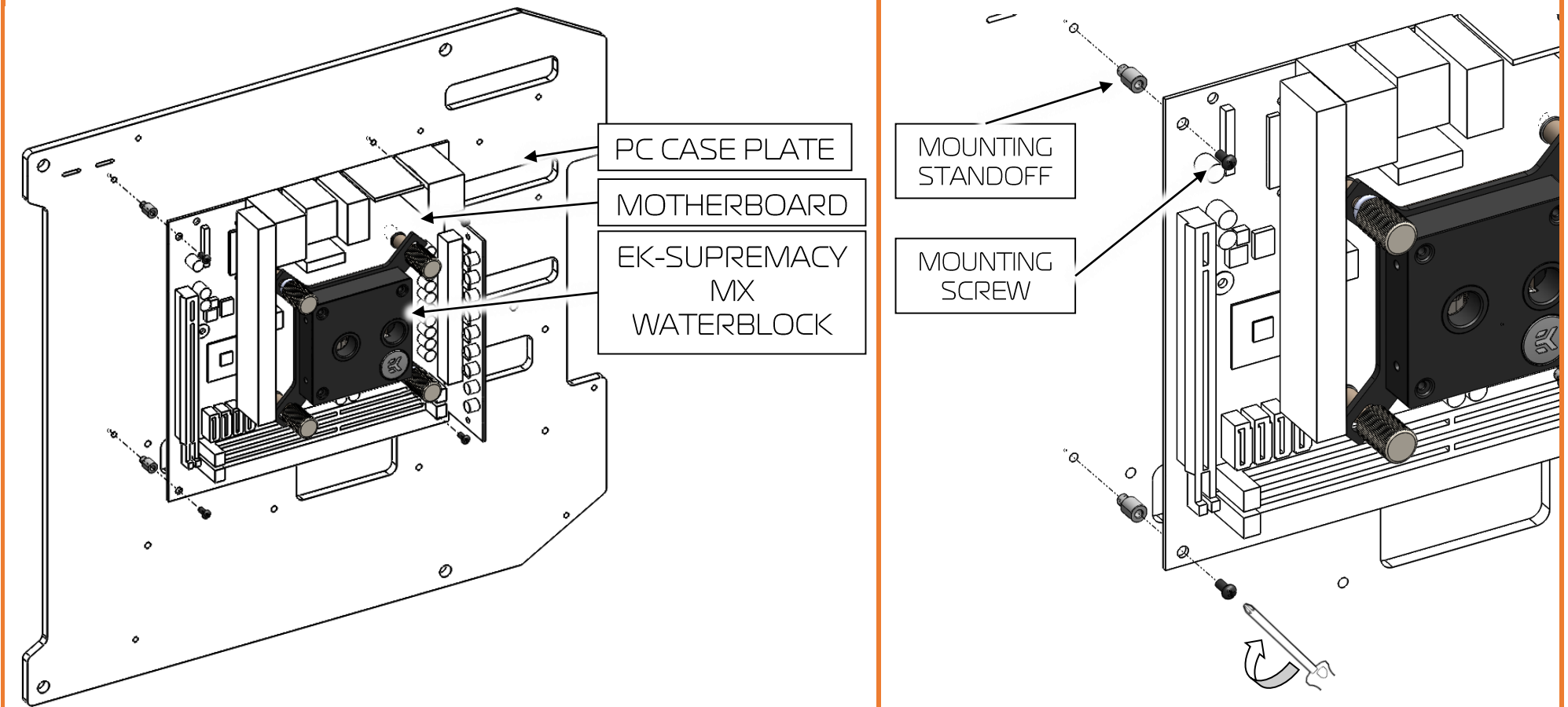

Take the PC case plate and install the necessary spacers and install the motherboard.

Secure the motherboard by screwing in motherboard mounting screws (provided with your Motherboard)

## 3. INSTALLING THE RADIATOR WITH FANS

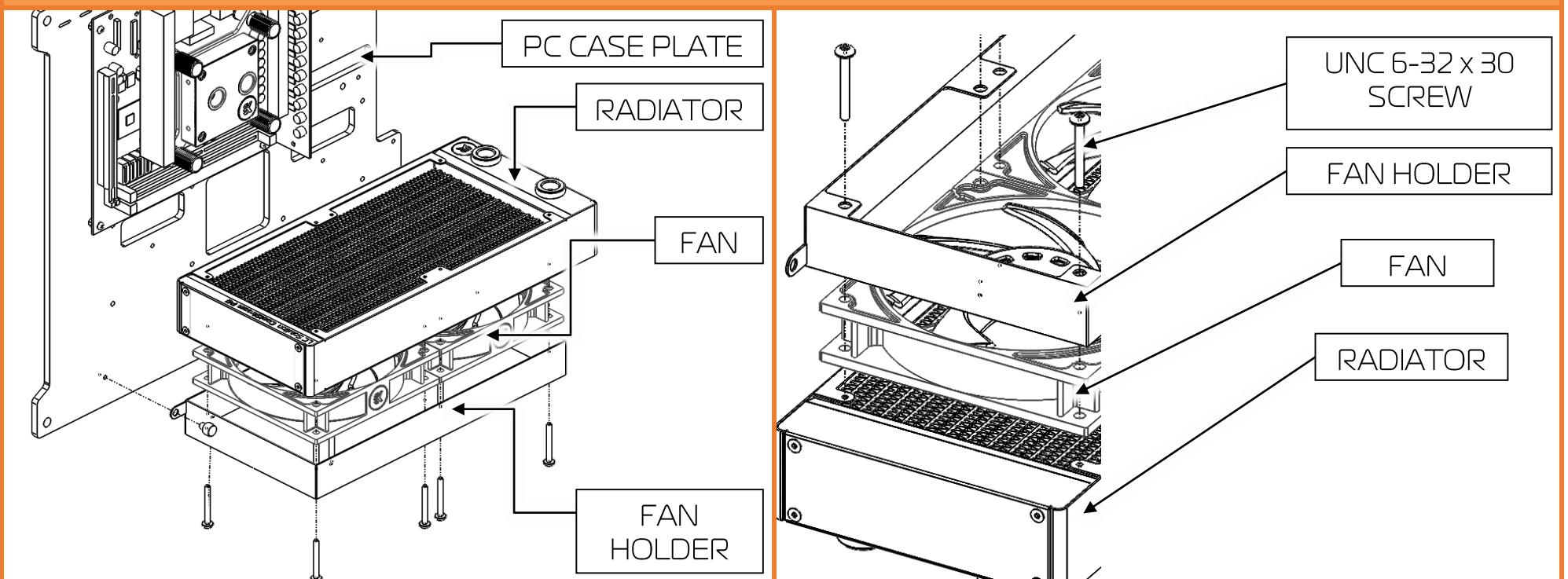

Take the fans and put it into the factory provided fan holder. Ideally, radiator should receive the coldest air possible. You must use the push mode, as it eases the fan cable routing.

First you need to assemble the fan, fan holder and the radiator. Take the four UNC 6-32 screws for each fan and route them through the fan holder holes and fan mounting holes and screw them into the radiator mounting holes.

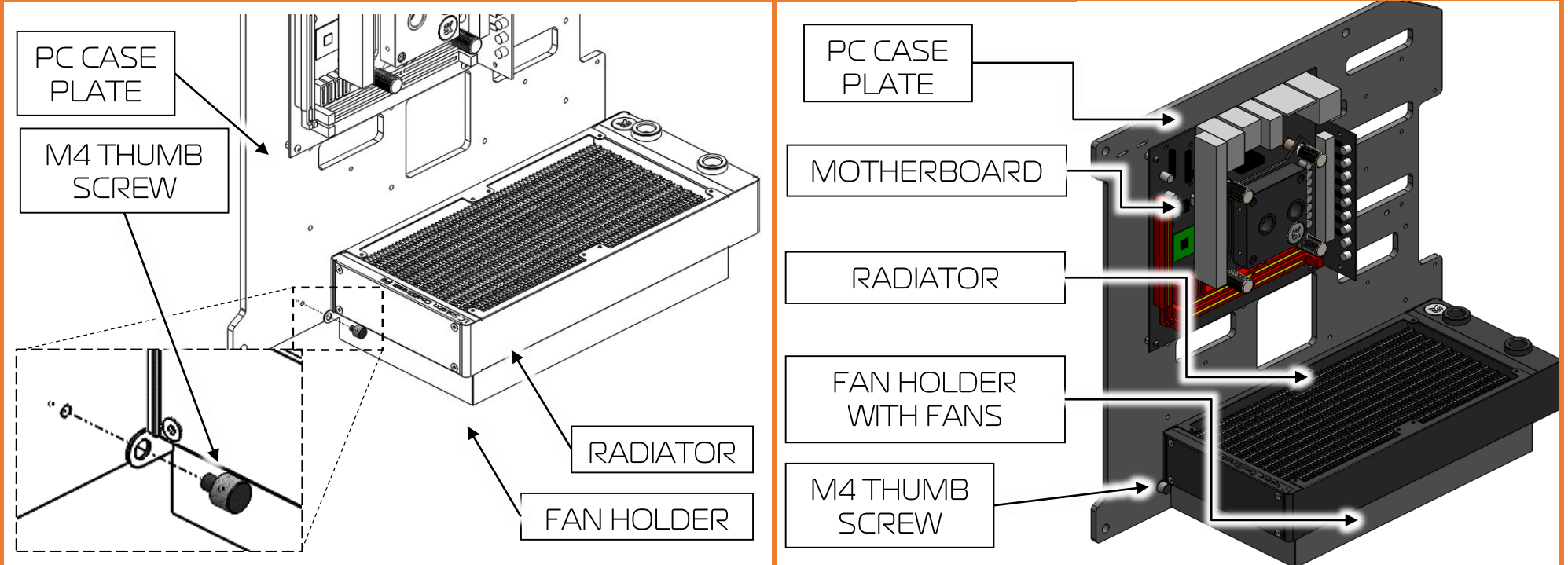

Secure the fans/radiator combo on the pc case plate with two M4 thumb screws, which come together with the case.

Please check again if all the elements are mounted according to the sketch above.



## 4. INSTALLING THE PUMP/RESERVOIR UNIT

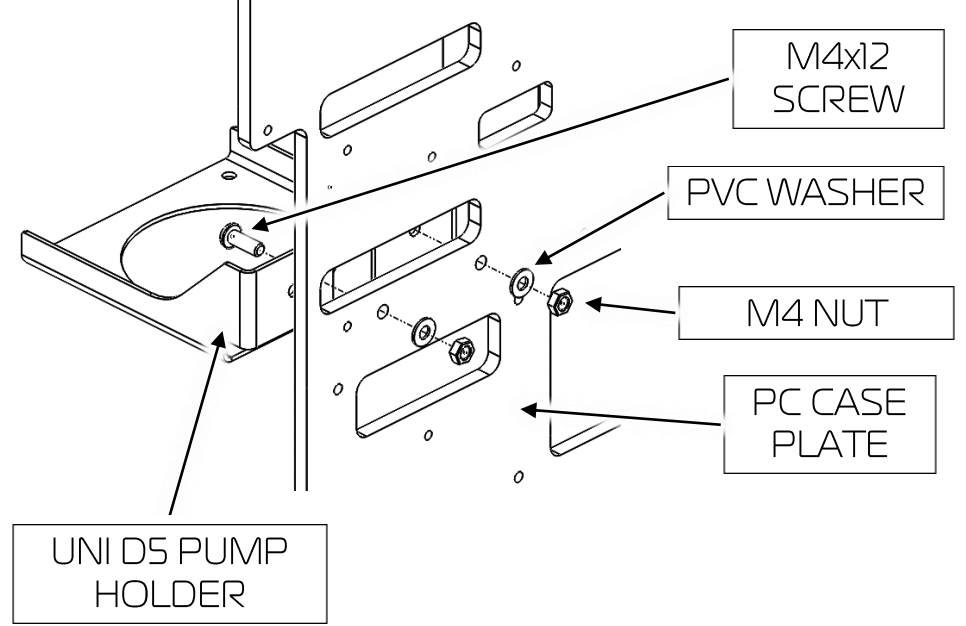
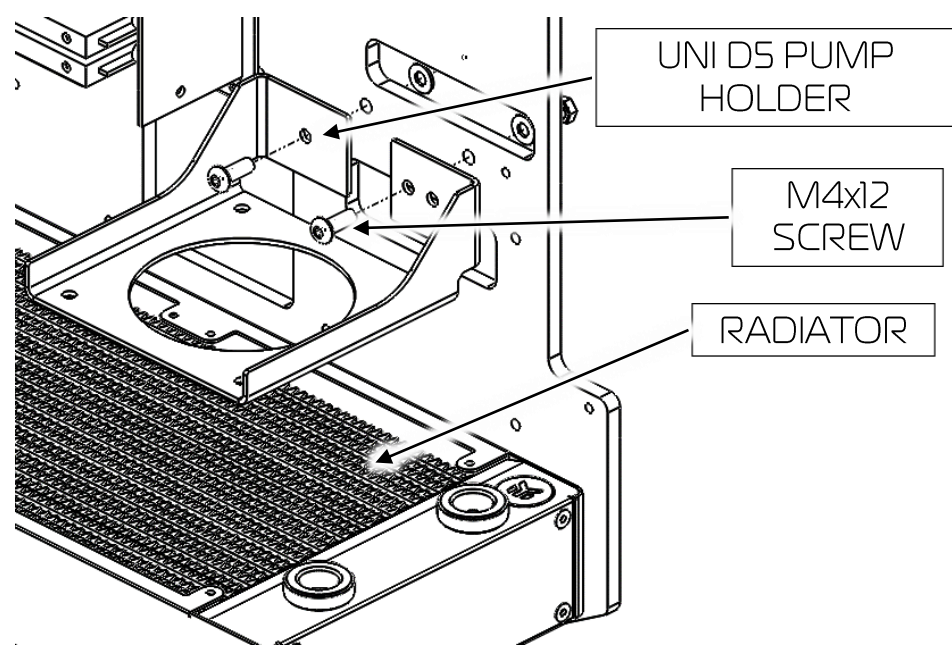

Mount your pump holder using two M4x12 screws from the front side. Use the pre-drilled holes, as shown on the sketch.

Secure the assembly screws using PVC washers and two M4 nuts.

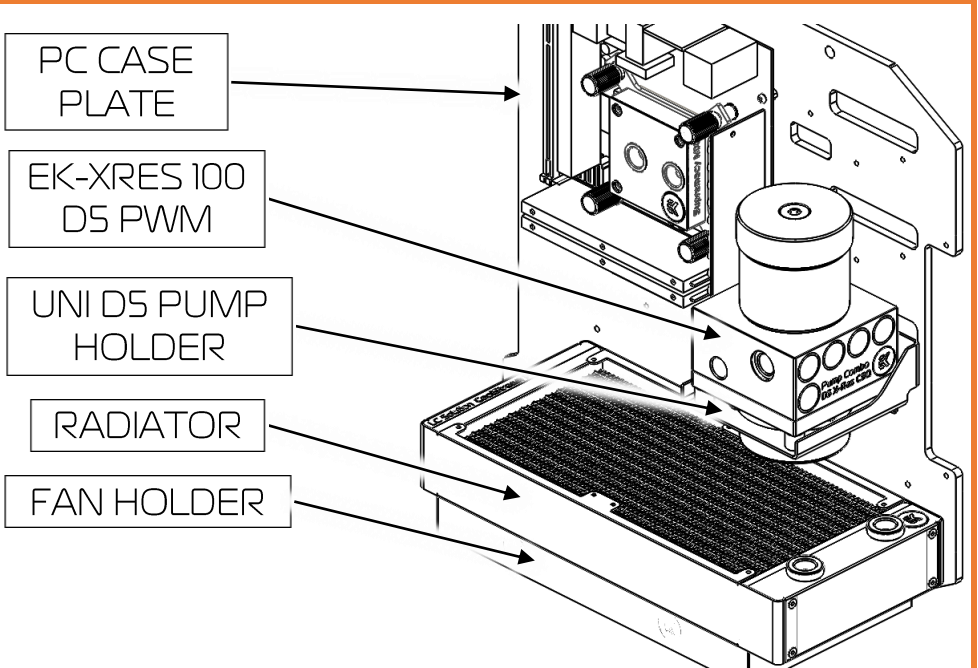
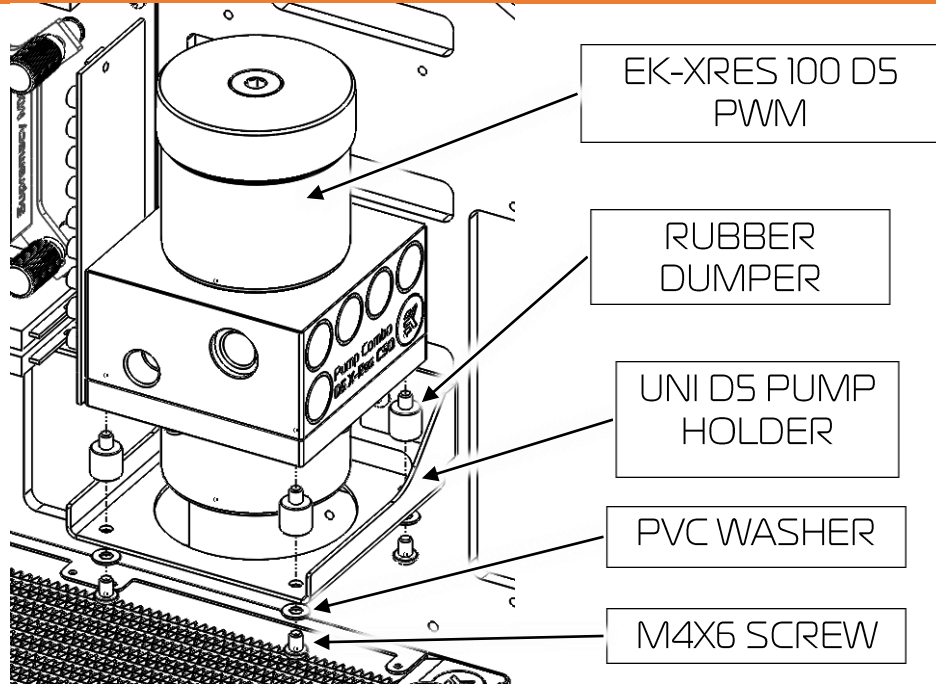

Mount the pump/reservoir combo on the pump holder. Please use four rubber dumpers, pvc washers and four M4x6 screws as shown on the sketch.

Make sure all the screws are tight as the vibrations that come from the pump may loosen them.

## 5. INSTALLING THE TUBING

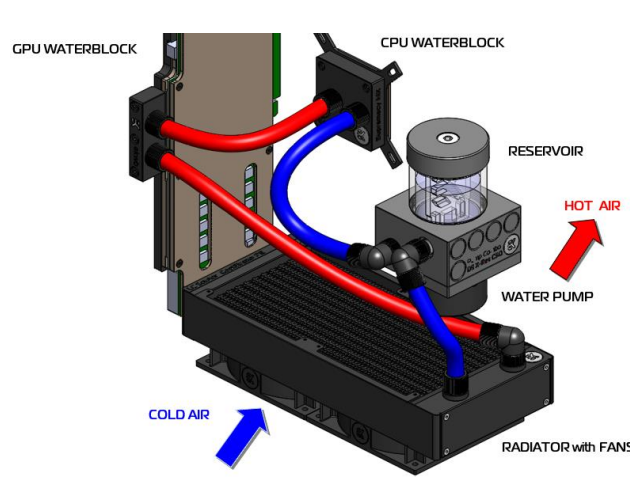

Examine the water loop diagram

Take a measure of required tubing length.

Cut the tube on marked spot.

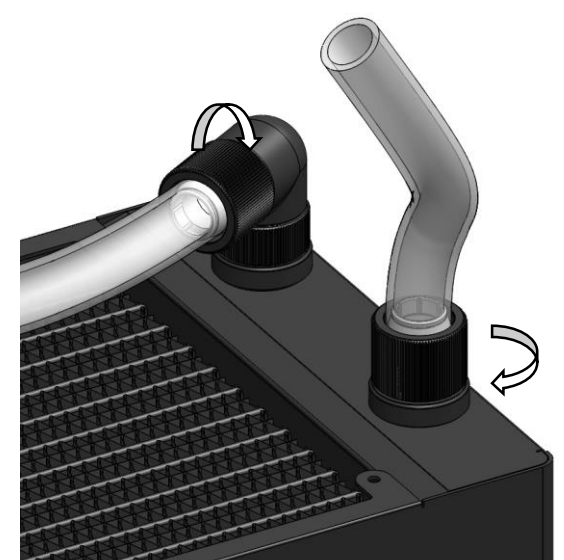
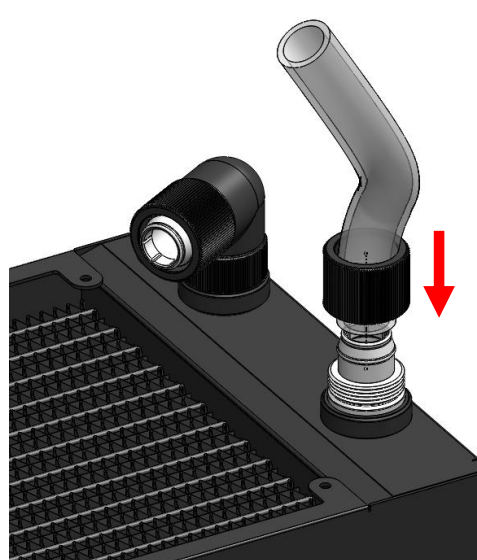
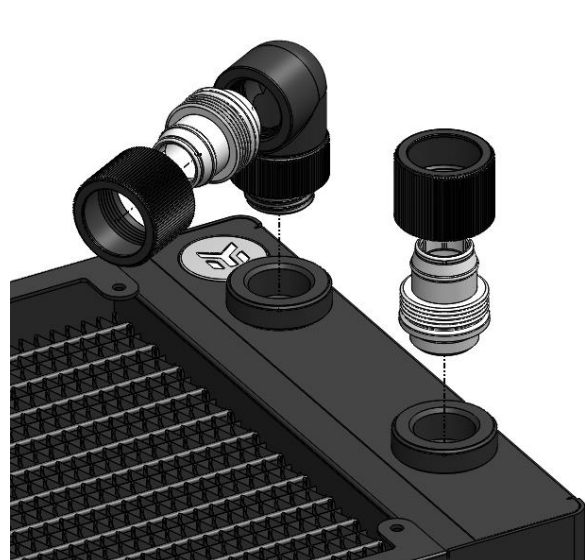

Install the compression fitting to one and 90° adapter with compression fitting on the other G1/4 opening on radiator.

Install the tube on the fittings. If needed heat the tube in warm water.

Screw in the securing ring of the fitting to secure the tube properly



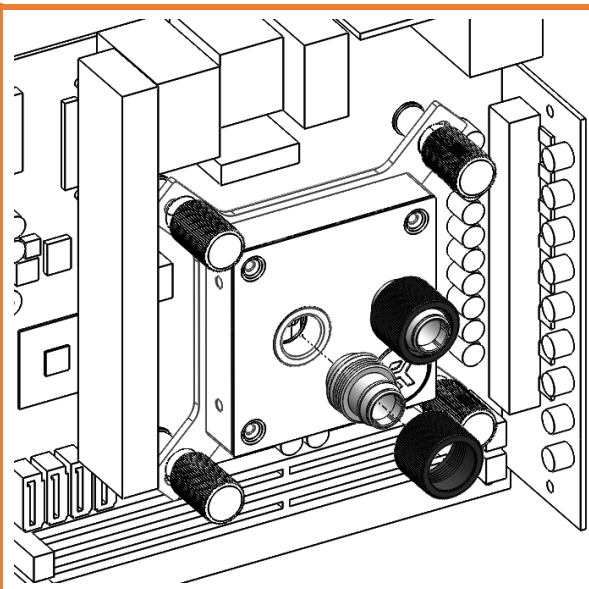

Repeat the procedure on CPU water block

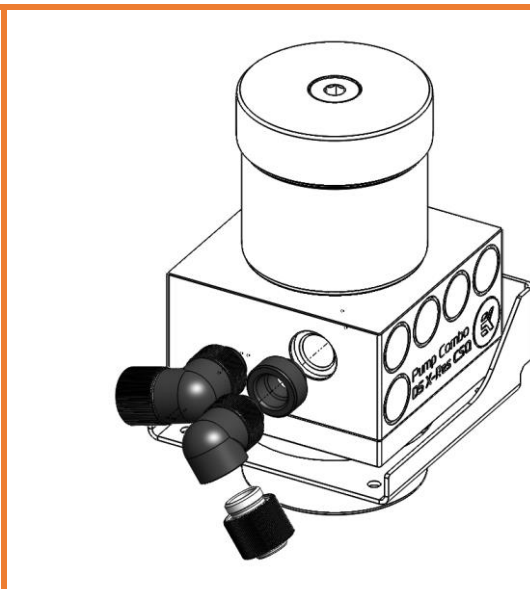

Repeat the procedure on the Pump/Reservoir unit. Screw in the fitting on the outlet and inlet port.

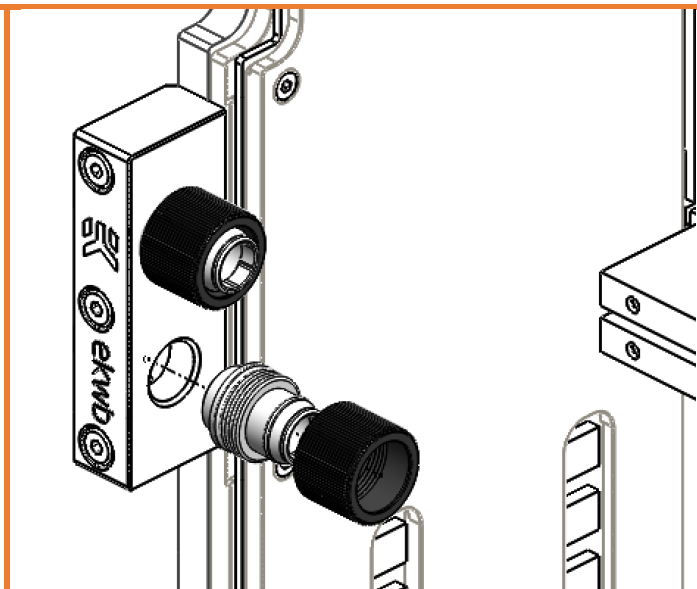

Repeat the procedure in the graphics card waterblock, if present.

## 6. CONNECTING THE PUMP AND FANS AND FILLING UP THE SYSTEM



Take the cable with adaptors from the pump delivery.

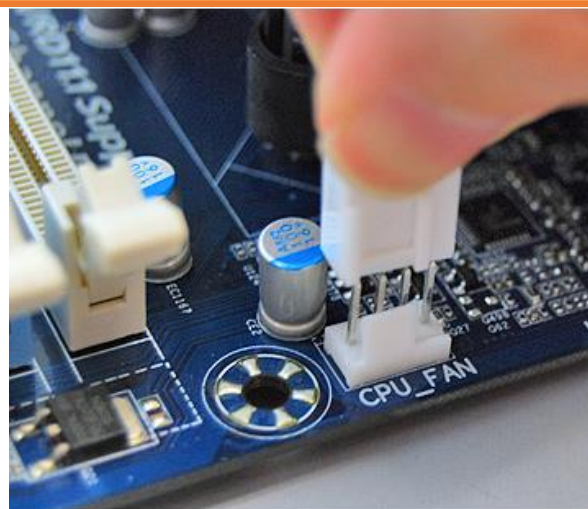

Connect pumps female 4-PIN connector to male connector of the motherboard.



Connect 4-pin Molex female connector to male Molex connector of the power supply.



Prepare enclosed Y fan splitter cable.

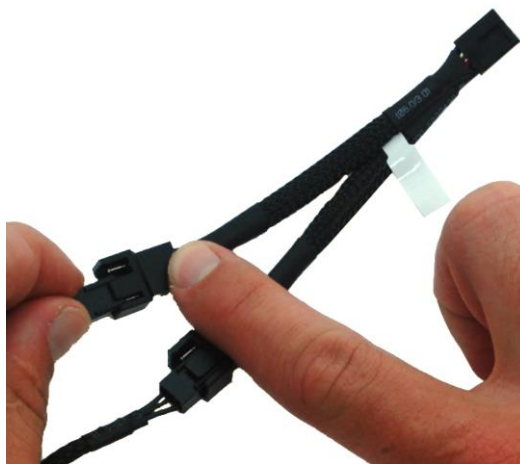

To connect the fans plug in 3-PIN female fan connectors to male fan splitter cable.

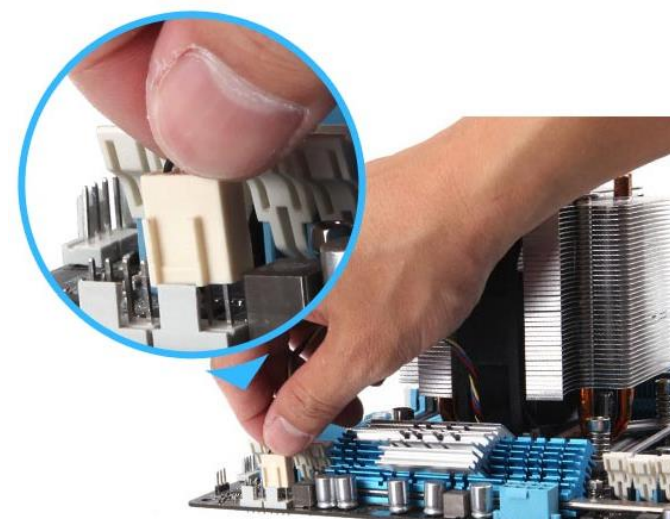

Connect the female fan splitter cable to motherboards male connector.



Prepare the ATX bridging plug enclosed with the kit. This gadget allows powering up the PSU without powering up the whole computer.

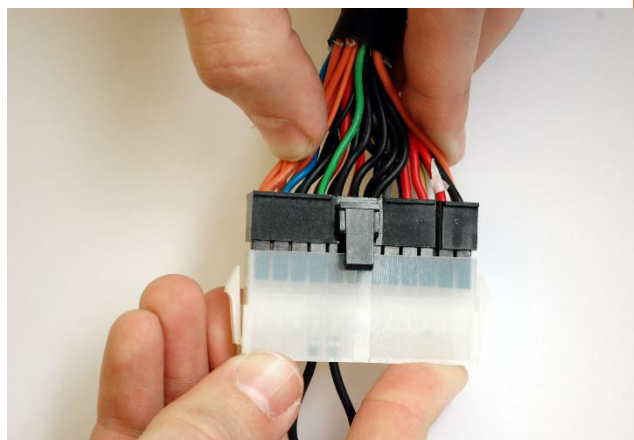

Plug in the ATX bridging plug. Make sure nothing except the pump is plugged to the power supply.



Take about 900 mL of distilled water





And fill in whole content (100mL) of the water additive concentrate

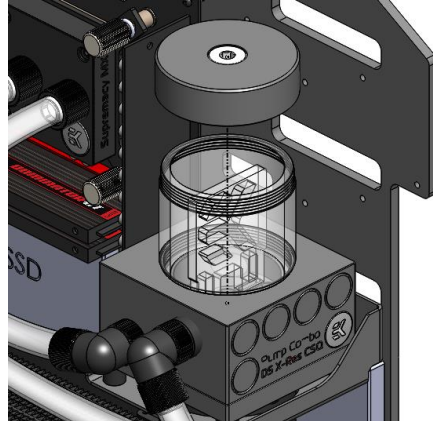

Open top of the reservoir.

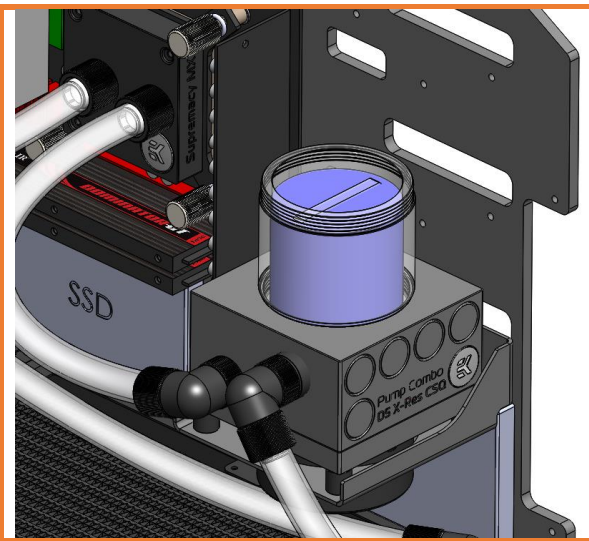

Fill in the ready liquid about 1 cm from the top



Turn on the power supply

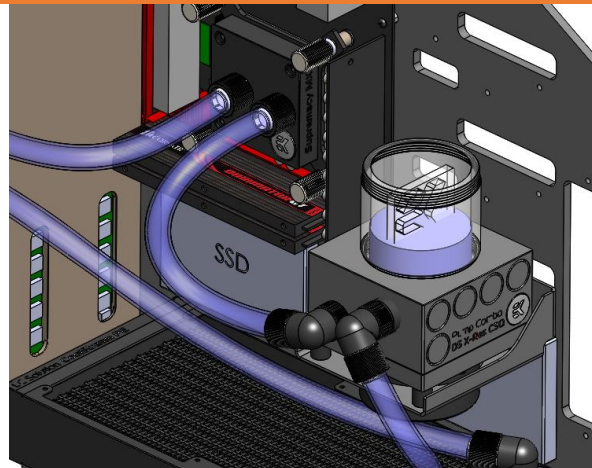

Fill up the liquid while the pump is running and stop when the water level reaches 2 cm under the edge

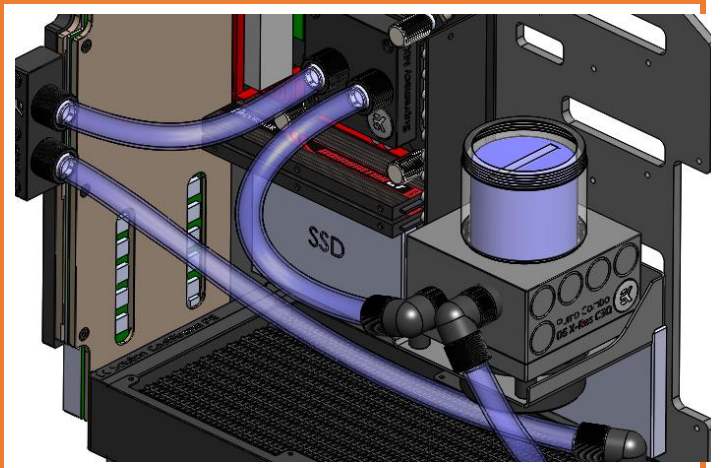

Alternately turn off and on (cycle) power supply in few second intervals to speed up air bleeding process.

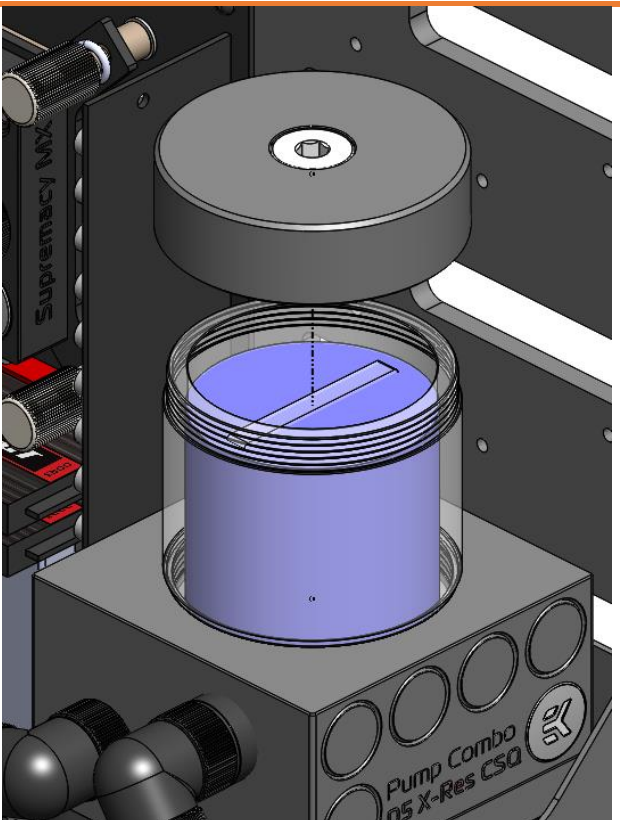

Close the reservoir by screwing in the top acetal endcap.

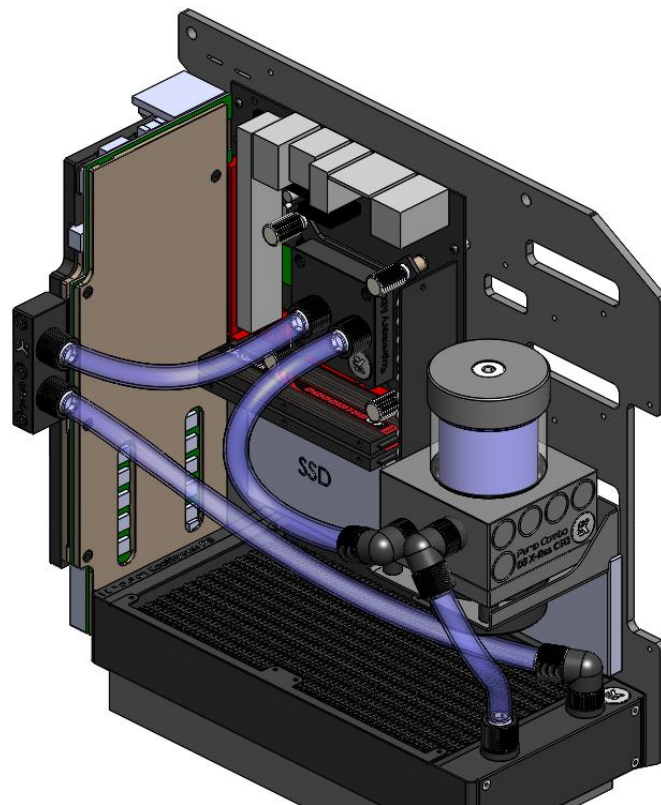

Shake and tip the PC case to remove any air possibly trapped in the radiator. You may need to add more coolant.

## 24 hour leak test

Once the 24 hour leak test has been completed and there is no sign of a leaking fluid you are free to finish your computer installation.

You will not be needing the ATX Bridging Plug any more. Connect all the necessary cables to the motherboard, graphics card and expansion drives.

Leave your PC case for 24 hour leak test, to ensure the system is leak free.



# 7. EMPTYING THE WATERCOOLING SYSTEM

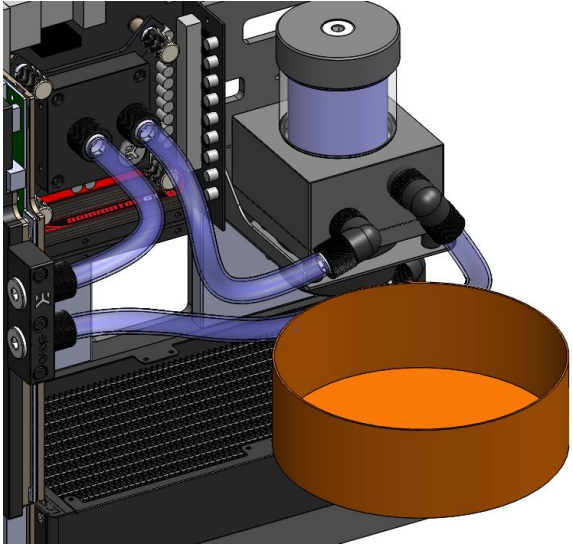

Cover all exposed hardware with a towel or paper towels. Put a container under reservoirs inlet and outlet ports.

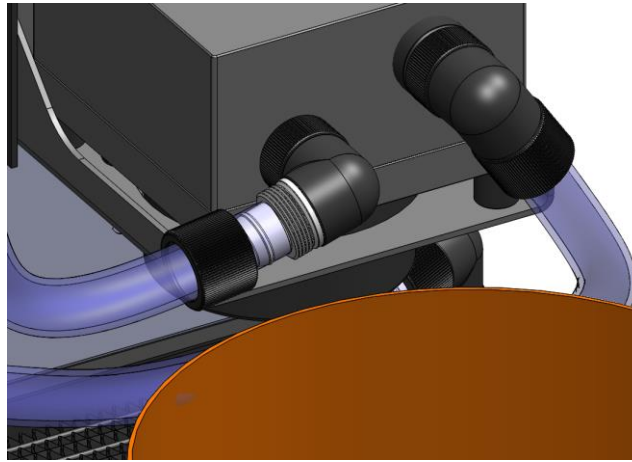

Unscrew one of the G1/4 fitting rings on the pump/reservoir combo.

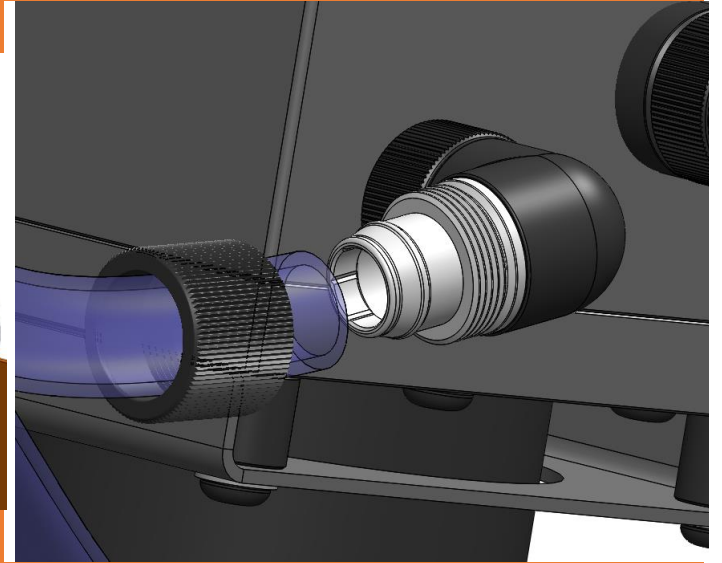

Gently pull the tube off the fitting and direct it into the container.

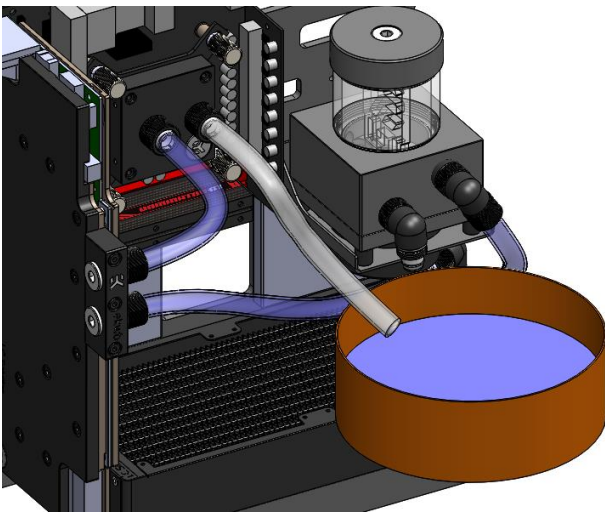

Let the water run away into the container

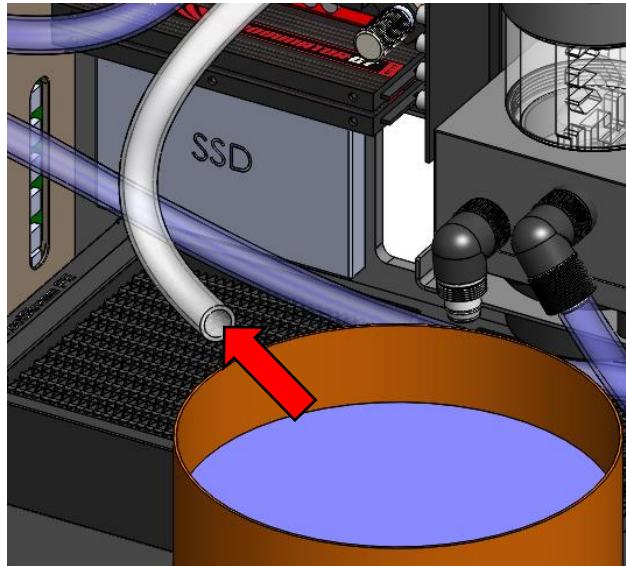

Keep one tube in the container and gently blow into the other tube to additionally drain the system.

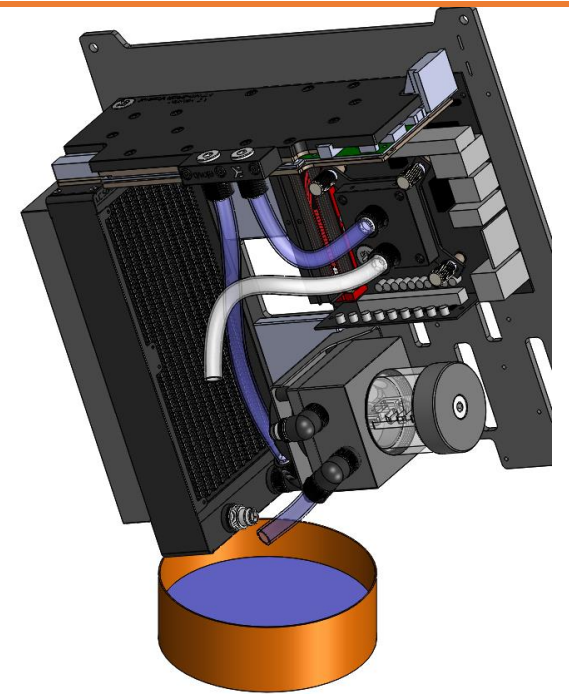

You may need to tilt the whole case in order to get all the fluid out of the system.

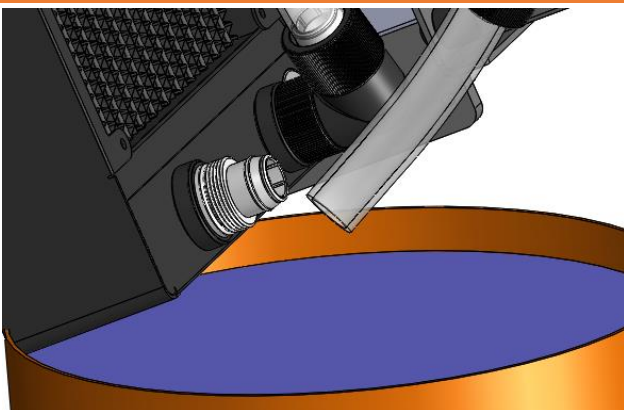

The best would be to unplug the pipe from the fitting on the radiator. Repeat

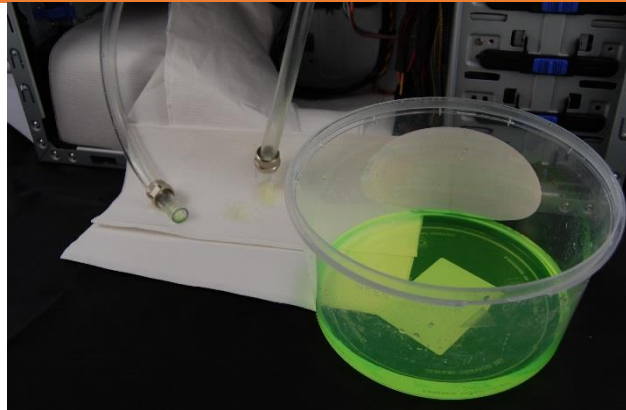

Keep the tubes over the towel to prevent water to spill over the hardware



Dry the tubes and pump with paper towel