

EK-Pro CPU WB 4677

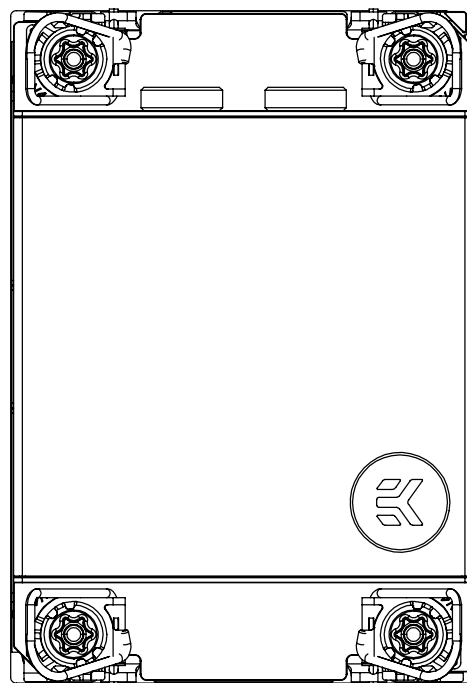
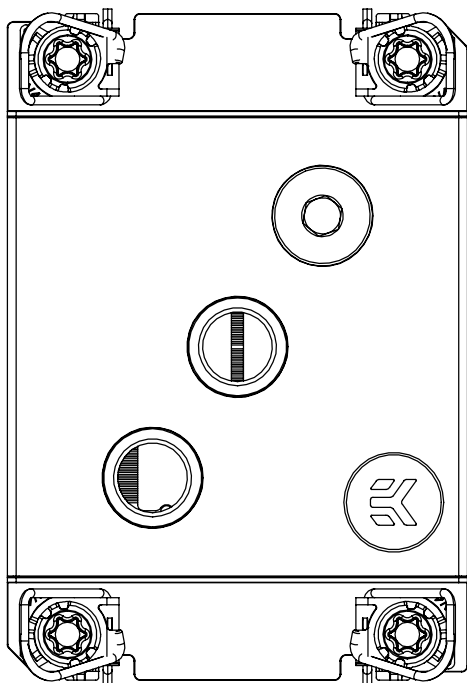

This product is intended for installation only by expert users. Please consult with a qualified technician for installation. Improper installation may result in damage to your equipment. EK Water Blocks assumes no liability whatsoever, expressed or implied, for the use of these products nor their installation. The following instructions are subject to change without notice. Please visit our website www.ekwb.com for updates. Before installing this product, please read the important notice, disclosure, and warranty conditions printed on the back of the box.

Before you start using this product, please follow these basic guidelines:

Please read the manual carefully before starting the installation process.

Please remove your graphics card from the computer to ensure the safest mounting process and prevent any possible damage to your GPU and/or graphics card circuit board (PCB).

The EK-HFB and EK-ACF type fittings require only a small amount of force to screw them firmly in place since the rubber O-ring gaskets ensure the liquid seal.

The use of corrosion inhibiting coolants is always recommended for any liquid cooling system.

Do not use pure distilled water. For best results, EK recommends the use of EK-CryoFuel coolants.

Make sure to bleed the air from your water block thoroughly, or you will not reach optimal performance.

TABLE OF CONTENTS

GENERAL INFORMATION ON WATER BLOCK COMPATIBILITY	4
BOX CONTENTS	5
TECHNICAL SPECIFICATIONS AND PRODUCT PARTS	6
INSTALLING THE WATER BLOCK	7
CLEANING THE CPU	7
ATTACHING THE PROCESSOR CARRIER TO THE WATER BLOCK	7
INSTALLING THE WATER BLOCK ASSEMBLY	8
INSTALLING THE FITTINGS	9
TESTING THE LOOP	10
SUPPORT AND SERVICE	11
SOCIAL MEDIA	11

GENERAL INFORMATION ON WATER BLOCK COMPATIBILITY

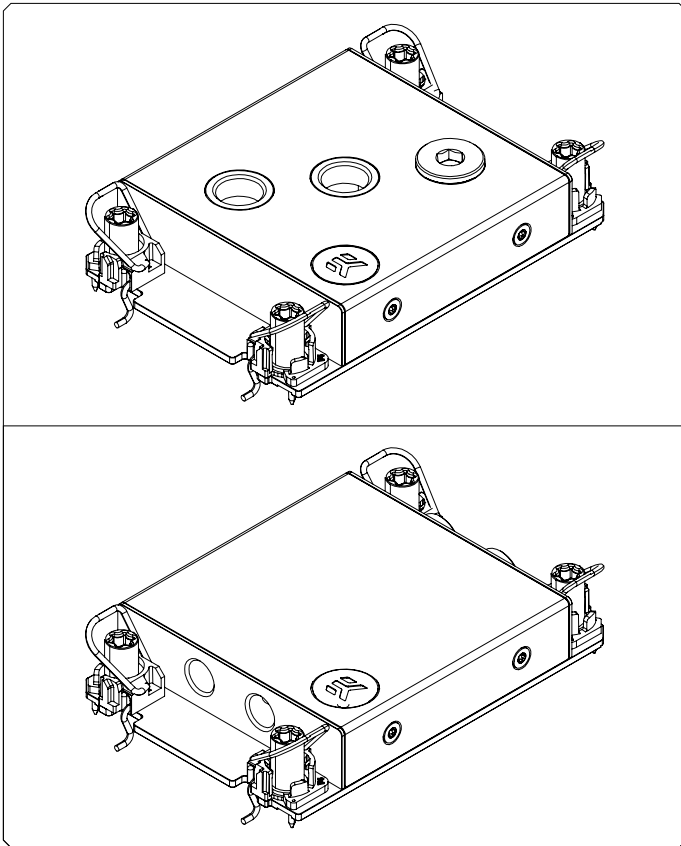

This CPU liquid cooling unit is pre-assembled for use with modern Intel server socket-type motherboards. By default (out of the box), this water block supports the following CPU sockets:

- Intel® Socket LGA-4677

BOX CONTENTS

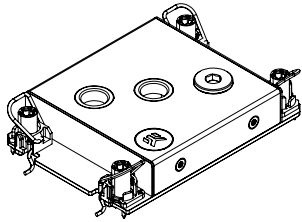

OR

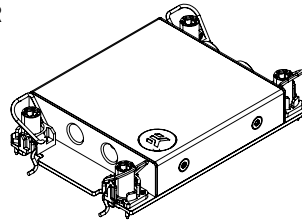

EK-Pro CPU Water Block LGA-4677

Mounting Mechanism EAN: 3831109849019

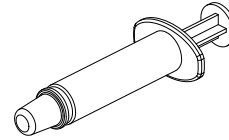

EK-TIM Ectotherm (1g)

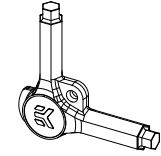

EK-Loop Multi Allen Key (6 mm, 8 mm, 9 mm) (1 pc)



Allen Key 5 mm (1 pc)



Torx T30 (1 pc)

TECHNICAL SPECIFICATIONS AND PRODUCT PARTS

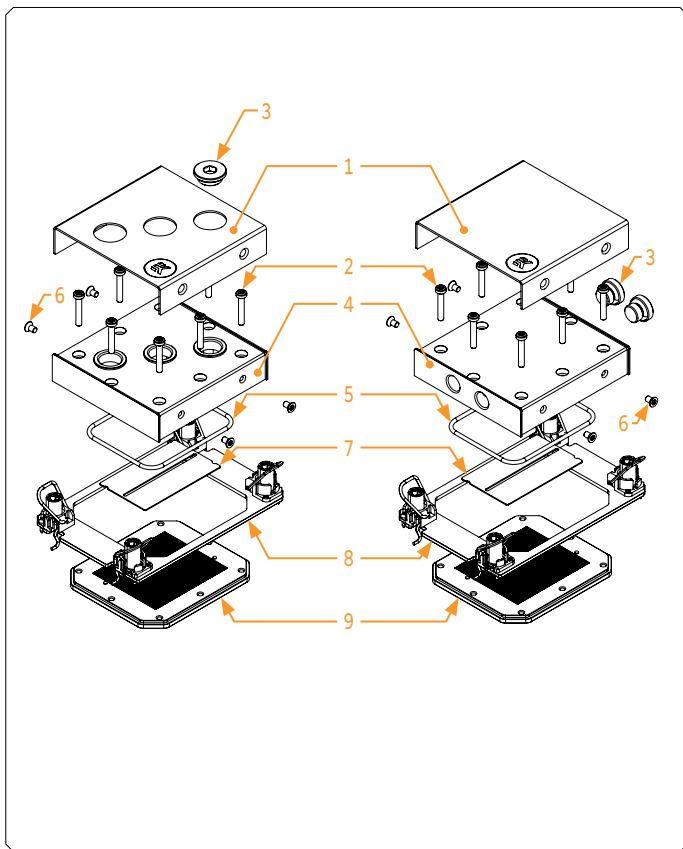

The following items are enclosed with each EK-Pro LGA-4189 water block, depending on the version: **EK-Pro LGA-4677 CPU water block**

3831109861103:

Position	EAN	Description	Quantity
1	103677	TOP - Cover Annihilator LGA4189	1
2	103759	M3x18 ISO 14583 Screw	8
3	103116	Plug G1/4	1
4	103675	TOP - PA66 EK Annihilator Pro	1
5	100442	O-ring 66 x 2 mm EPDM70	1
6	103089	M3 x 5 ISO 14581 Screw	4
7	103679	Annihilator Pro Jet	1
8	3831109861097	EK - Mounting Plate Pro CPU WB LGA4677	1
9	103674	Coldplate Ni	1

3831109861110 Ni rack + POM-C:

Position	EAN	Description	Quantity
1	103717	TOP - Cover Annihilator LGA4189 Rack	1
2	103759	M3 x 18 ISO 14583 Screw	8
3	3830046996435	Plug G1/8	2
4	103676	TOP - PA66 EK Annihilator Pro Rack	1
5	100442	O-ring 66 x 2 mm EPDM70	1
6	103089	M3x5 ISO 14581 Screw	4
7	103679	Annihilator Pro Jet	1
8	3831109861097	EK - Mounting Plate Pro CPU WB LGA4677	1
9	103674	Coldplate Ni	1

INSTALLING THE WATER BLOCK

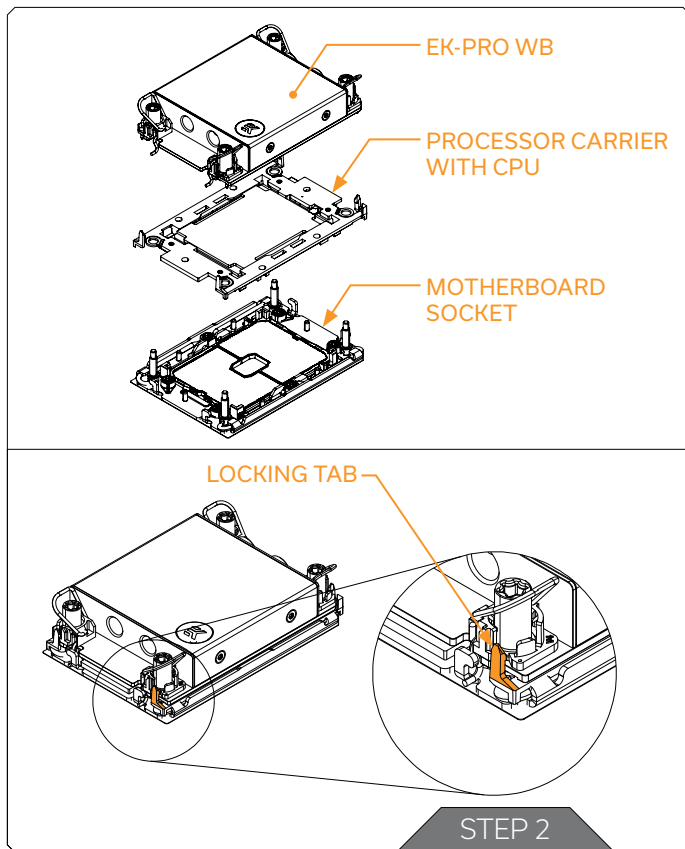

STEP 1 CLEANING THE CPU

Wipe the CPU's contact surface (by using non-abrasive cloth or Q-tip). Applying thermal compound: on a clean IHS, apply a line of thermal compound and spread it over the whole CPU heat spreader (IHS) with a credit card or equivalent.

The layer of the thermal compound must be thin and even in thickness through the whole surface of the IHS. A too-thick application could lead to poor performance.

STEP 2 ATTACHING THE PROCESSOR CARRIER TO THE WATER BLOCK



Before proceeding with the installation, it is mandatory to remove the protective foil from the backside of the water block. The CPU should be attached to the processor carrier before you start this step. The carrier typically comes with the server system or motherboard.

Align the water block with the processor carrier. Gently press the water block down onto the processor carrier. Make sure that all the locking tabs in all four corners lock into place before continuing.

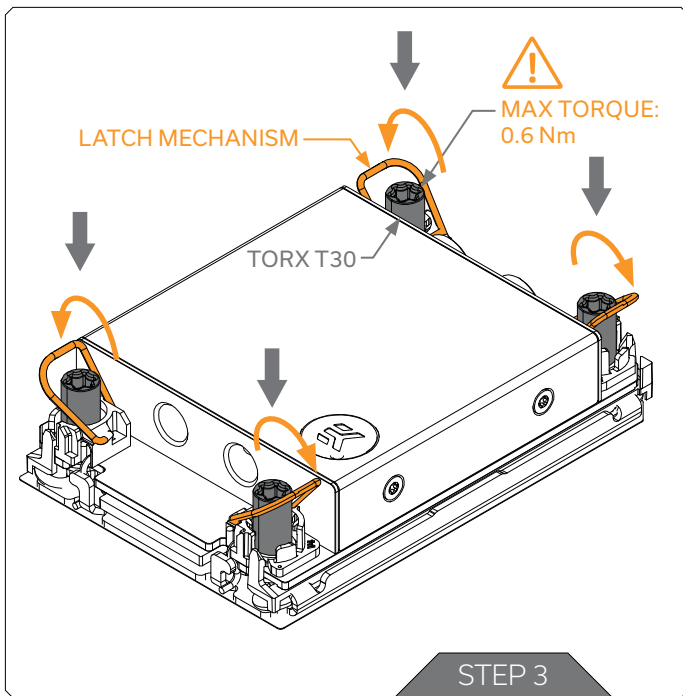

STEP 3

INSTALLING THE WATER BLOCK ASSEMBLY

Align the water block with the processor carrier attached over the mounting screws on the LGA-4677 motherboard. Make sure the processor is oriented correctly, aligning the PIN 1 corners on the processor carrier and the socket.

Lower the water block onto the LGA-4677 socket integrated latch mechanism (ILM). Press the latches into the locked position to level the water block and ensure even contact across the whole CPU. Next, use a T30 TORX screwdriver and tighten the corner nuts with 0.6 Nm of torque. We recommend the use of EK-Loop Torque Screwdriver - 0.6Nm or equivalent.



It is recommended to remove the motherboard from the PC chassis before proceeding with the installation of the processor and water block assembly because of the space constraints of different computer cases.

The installation of the CPU water block is now complete.

STEP 4 INSTALLING THE FITTINGS

Carefully identify the direction of the flow in your circuit. For the non-rack version, EK recommends the use of EK-HFB 10 mm barb fittings and EK-Tube ZMT 10/16 mm Matte Black tubing. For the rack version, EK-HFB Fitting 6 mm G1/8 and EK-Tube ZMT 6/9mm Matte Black tubing is recommended.

With EK-Pro CPU non-rack water blocks, it is mandatory to use the port in the center of the water block as the inlet port. For the rack version, the inlet port is on the right on both sides. Mixing the ports may result in lesser thermal performance of the water block.

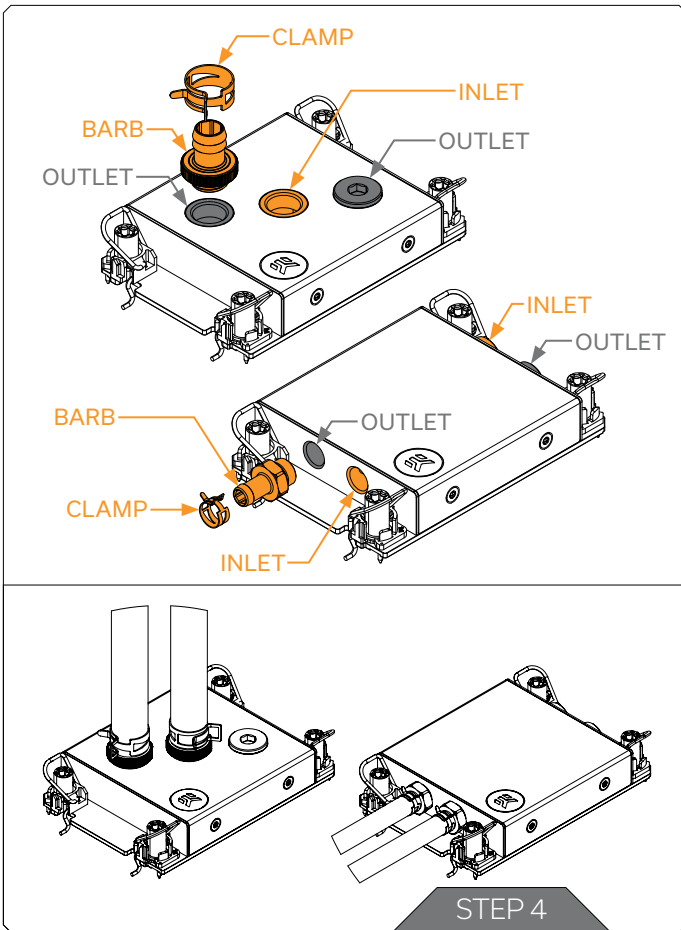

STEP 4

TESTING THE LOOP

To ensure the installation of EK components was successful, we recommend you perform a 24-hour leak test.

When your loop is complete and filled with coolant, connect the pump to a PSU outside your system. Do not connect power to any of the other components. Turn on the PSU and let the pump run continuously.

Inspect all parts of the loop, and in case the coolant leaks, fix the issue and repeat the testing process. To prevent possible damage, please ensure that all hardware is dry before the system is powered on.

SUPPORT AND SERVICE

In case you need assistance or wish to order spare parts or a new mounting mechanism, please contact:

<https://www.ekwb.com/customer-support/>

For spare parts orders, refer to the page with "TECHNICAL SPECIFICATIONS AND PRODUCT PARTS" where you can find the EAN number of each part you might need.

Include the EAN number with quantity in your request. Mounting Mechanism EAN can be found under "BOX CONTENTS".

Thermal pads are readily available in the EK shop.

SOCIAL MEDIA

 EKWaterBlocks

 @EKWaterBlocks

 ekwaterblocks

 EKWBofficial

 ekwaterblocks

