

This product is intended for installation only by expert users. Please consult with a qualified technician for installation. Improper installation may result in damage to your equipment. EK Water Blocks assumes no liability whatsoever, expressed or implied, for the use of these products, nor their installation. The following instructions are subject to change without notice. Please visit our web site at www.ekwaterblocks.com for updates. Before installation of this product please read important notice, disclosure and warranty conditions printed on the back of the box.

STEP 1: GENERAL INFORMATION. Sample picture of ASUS HD7970 DC2(T) graphics card

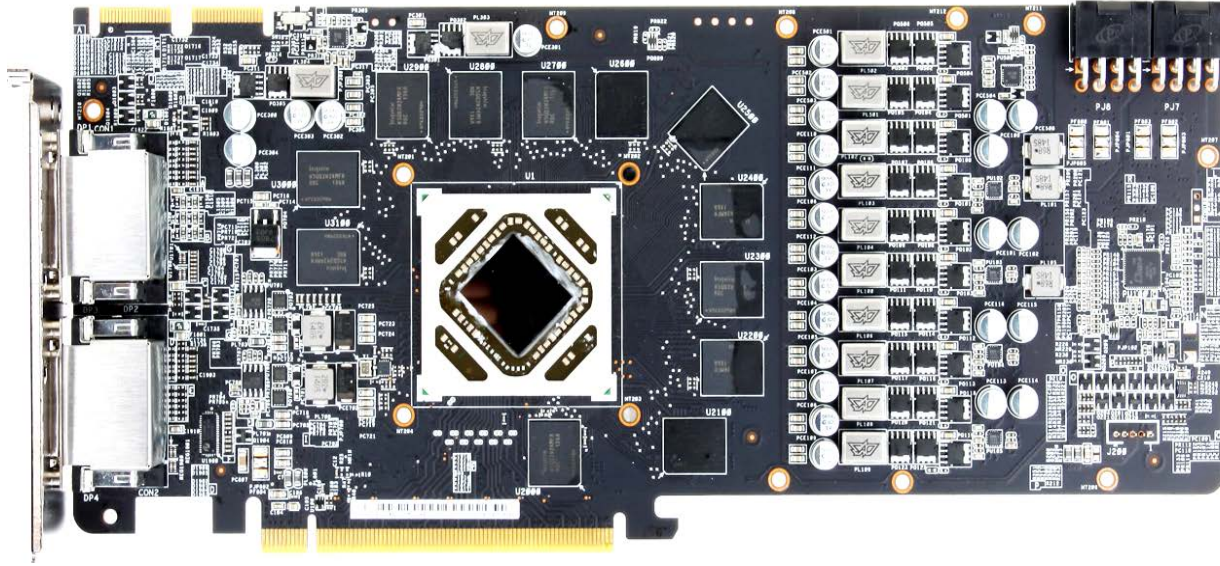

STEP 2: PREPARING YOUR GRAPHICS CARD

EK-FC7970 DCII Backplate is very easy to install. If you have installed your EK-FC7970 DCII water block with the original ASUS backplate you will need to remove this backplate and all screws attaching the water block first. Please remove all four (4) M3x4 screws, three (3) M3x6 screws and four (4) M3x8 screws marked with arrow and then remove the backplate. Once you remove the factory backplate remove the two screws holding the water block to the PCB (hidden underneath).

After the removal of screws and original backplate please re-install 7 (seven) M3x4 DIN7985 screws and washers (provided with the EK-FC7970 DCII water block) as shown on right picture.

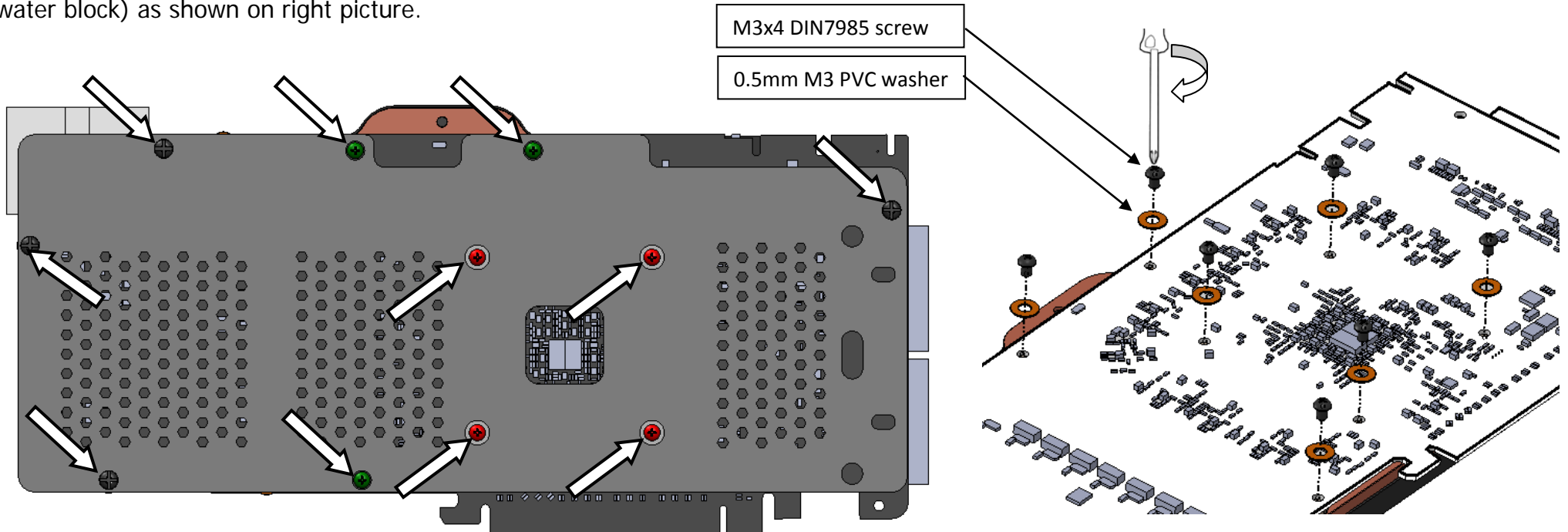

STEP 3: APPLYING THE THERMAL PADS

EK-FC7970 DCII Backplate features passive cooling of the printed circuit board and its components therefore it is mandatory to install the enclosed thermal pad. Please install enclosed 1mm thick thermal pad (Thermal Pad B – 1mm (75x50)) directly on the extruded stub on the backplate itself as shown on the picture below. You may need to trim the excess thermal pad.

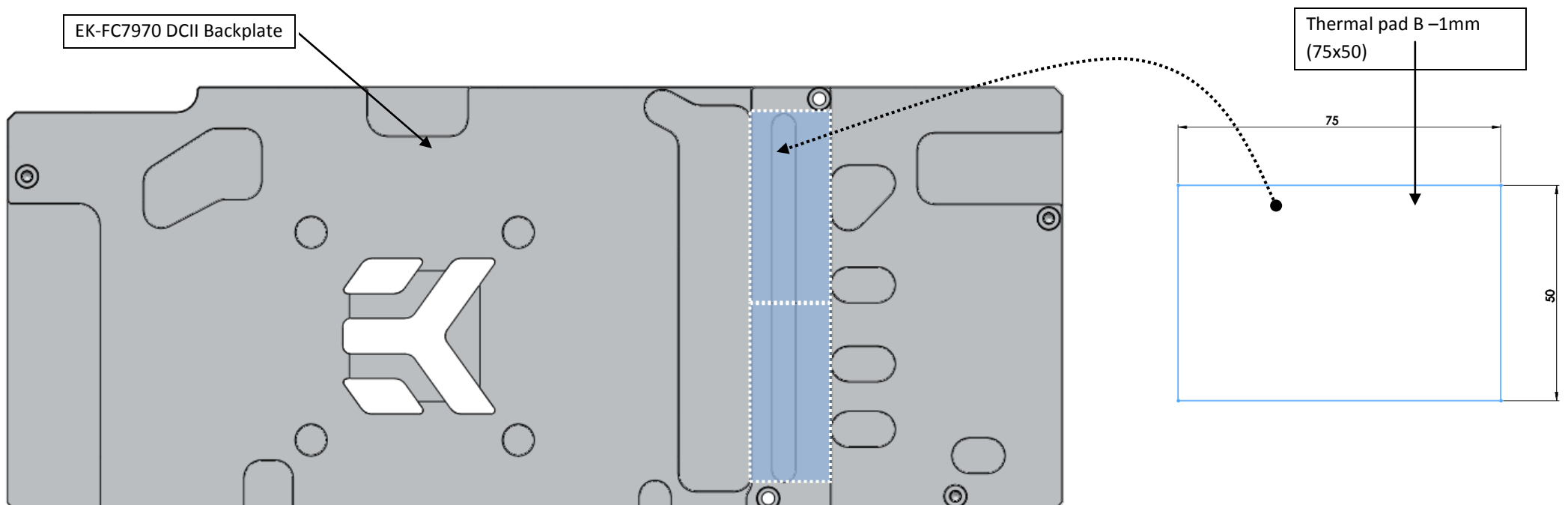

STEP 3: ATTACHING EK-FC7970 DC11 BACKPLATE TO THE GRAPHICS CARD

Take enclosed mounting screws and install them as shown on picture below. EKWB recommends users to start with two (2) M3x9 DIN7991 screws (HINT: do not tighten screws until they are all positioned in their mounting holes) and then continue with mounting of three (3) M3x4 DIN7985 screws. Backplate has milled in standoffs, so there is no fear of over tightening the screws. Nevertheless do not exaggerate with screwing force as there is no need for it.

(Please note that EKWB holds no responsibility of any kind if assembly is not made by instructions. This applies also for all products that are not out of EKWB production line. Users must by all means also consider instructions that are being made for proper use of FC blocks.)

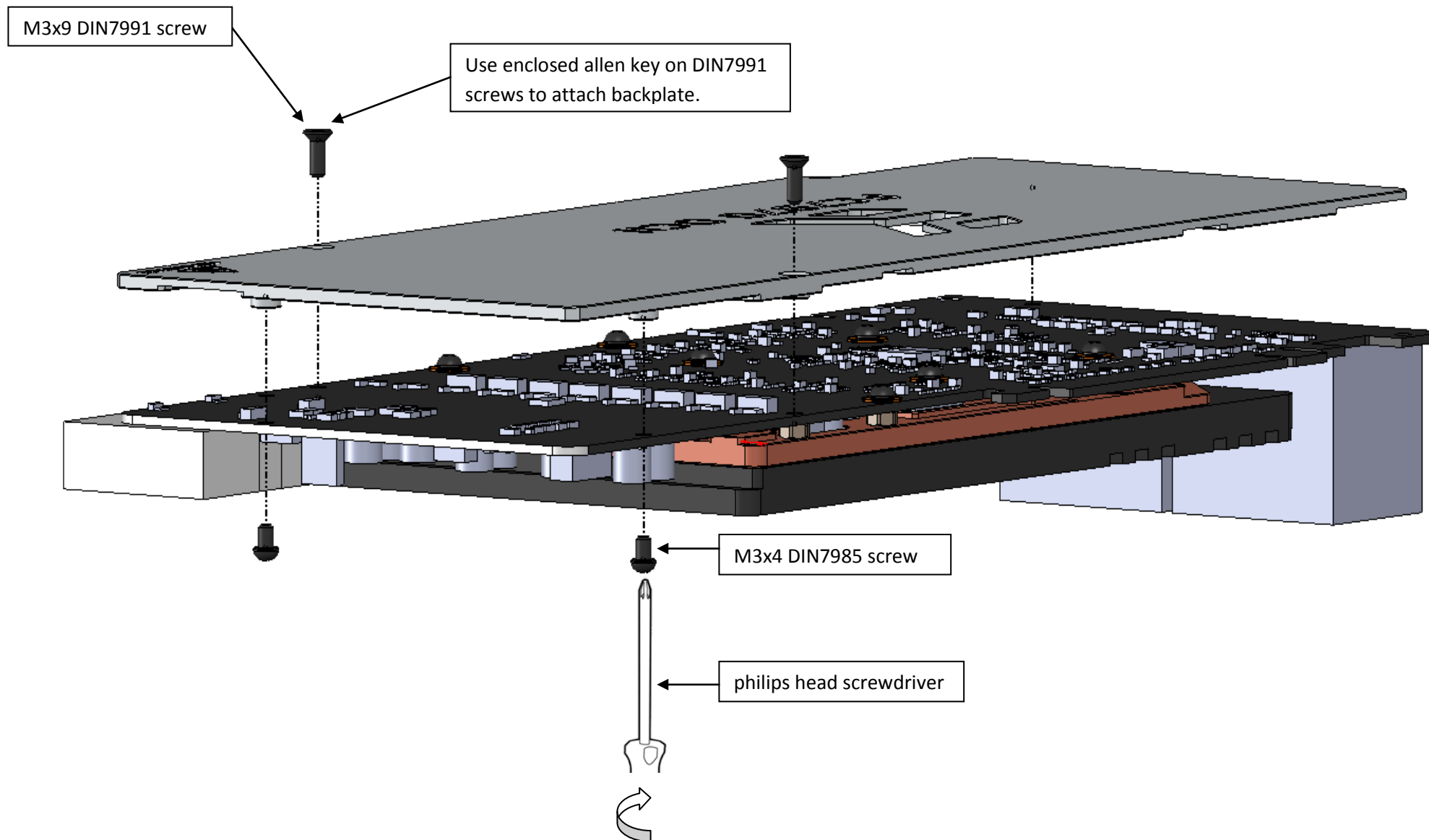

IMPORTANT DISCLOSURES

VERY IMPORTANT NOTICE: Once the installation is completed, it is a recommended practice to test the cooling circuit for leaks prior to powering up the computer. We recommend a 24 hour leak test prior to powering up the computer. Do not test the water block using city water pressure. This will rupture the top of the housing and render the block unusable (and will void your warranty). While all efforts have been made to provide the most comprehensive tutorial possible, EK Water Blocks assumes no liability expressed or implied for any consequential damage(s) occurring to your equipment as a result of using EK Water Blocks cooling products, either due to errors or omissions on our part in the above instructions, or due to failure or defect in the EK Water Blocks cooling products.

WARRANTY:

Our products are warranted against defects in materials or workmanship for a period of 24 months beginning from the date of delivery to the final user. During this period, products will be repaired or have parts replaced at our discretion provided that: (I) the product is returned to the agent from whom it was purchased; (II) the product has been purchased by an end user and has not used for commercial purposes; (III) the product has not been misused, handled carelessly, or used in a manner other than in accordance with the instructions provided describing its installation and proper use. This warranty does not confer rights other than those expressly set out above and does not cover any claims for consequential loss or damage. This warranty is offered as an extra benefit and does not affect your statutory rights as a consumer. This warranty is voided if the product comes in contact with aggressive UV additives or other improper liquids.

EK blocks are sealed with warranty void circular label, which proves that the block has withstood a pressure leak test. Removing it will void leak-free guarantee and not the guarantee on the product itself. Any other RMA issues can be reported to support@ekwaterblocks.com for further analysis.

REQUIRED TOOLS:

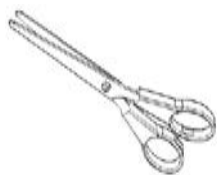

scissors



philips screwdriver



2mm allen key