

This product is intended for installation only by expert users. Please consult with a qualified technician for installation. Improper installation may result in damage to your equipment. EK Water Blocks assumes no liability whatsoever, expressed or implied, for the use of these products, nor their installation. The following instructions are subject to change without notice. Please visit our web site at www.ekwaterblocks.com for updates. Before installation of this product please read important notice, disclosure and warranty conditions printed on the back of the box or our home page.

The barb hose fittings require only a small amount of force to screw them in; otherwise the high flow fittings might break. These fittings do not need to be tightened with much force because the liquid seal is made using o-rings. The use of an algacide and corrosion inhibitors is always recommended for any liquid cooling system.

STEP 1: GENERAL INFORMATION. Sample picture of GeForce 570 GTX HD graphics card (PCB NVA-P1263)



STEP 2: PREPARING YOUR GRAPHIC CARD.

1. REMOVING STOCK COOLER: Remove encircled screw on the bracket (required only on certain models):

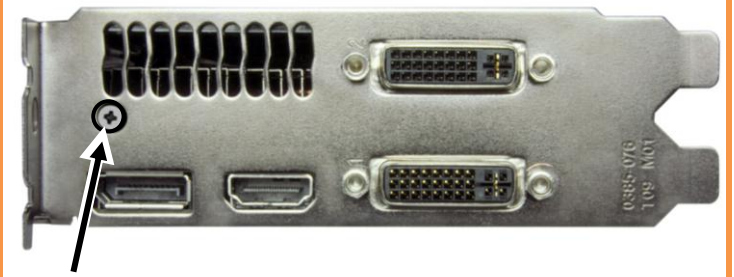

STEP 2 cont.: PREPARING YOUR GRAPHIC CARD

1 cont.. REMOVING STOCK COOLER. Remove all encircled screws. All heat sink assembly screws should be removed. There are 17 screws on the back of the graphic card.

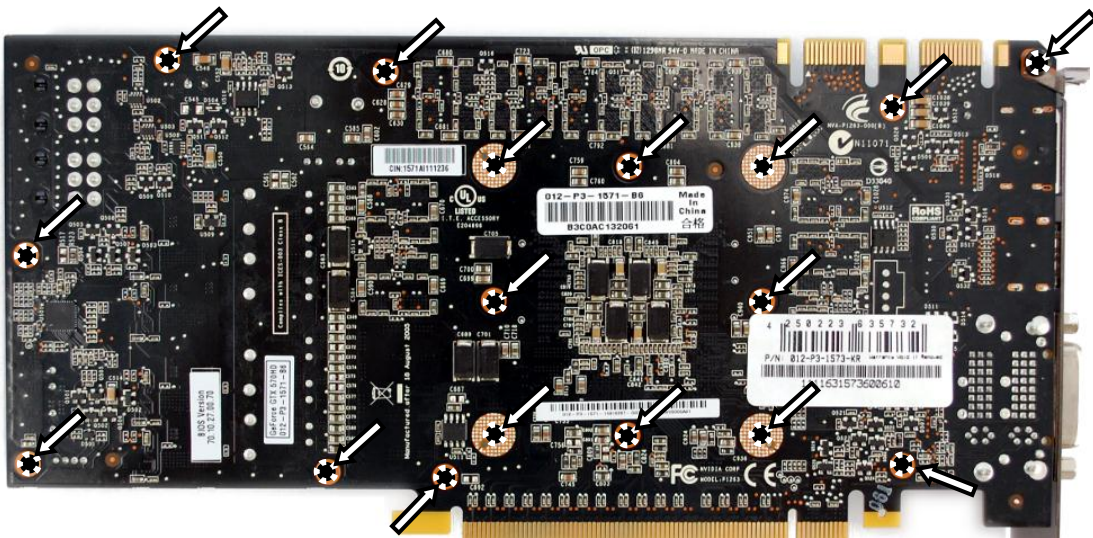

2. CLEANING THE PCB. Carefully detach the original heat sink after removing all fasteners securing it to the board and bracket. Wipe off the remains (by using non-abrasive cloth or Q-tip, as shown on sample photo) of the original thermal compound until the components and circuit board are completely clean. EKWB does not recommend using any liquids for removing paste.



3. APPLYING THERMAL COMPOUND. Apply thermal compound: lightly coat nVidia GF110 GPU chip with for example Arctic Cooling MX-2™ or MX-4™ thermal grease. EKWB recommends to apply thermal grease in cross form for best performance (see sample picture).

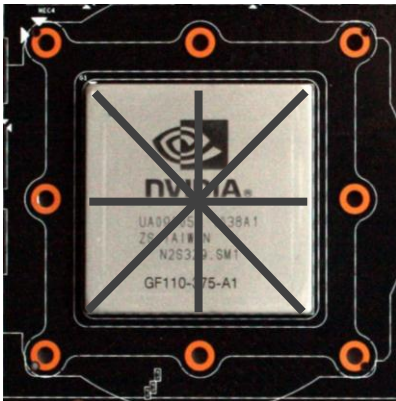

4. CUTTING THERMAL PADS. Your block comes with thermal pads, some of which are already pre-cut. Others have to be cut to smaller chunks in order to cover all the VRM components such as MOSFETs and inductors (chokes). PLEASE REMOVE THE PROTECTIVE FOIL FROM BOTH SIDES OF THE THERMAL PADS PRIOR TO INSTALLATION.

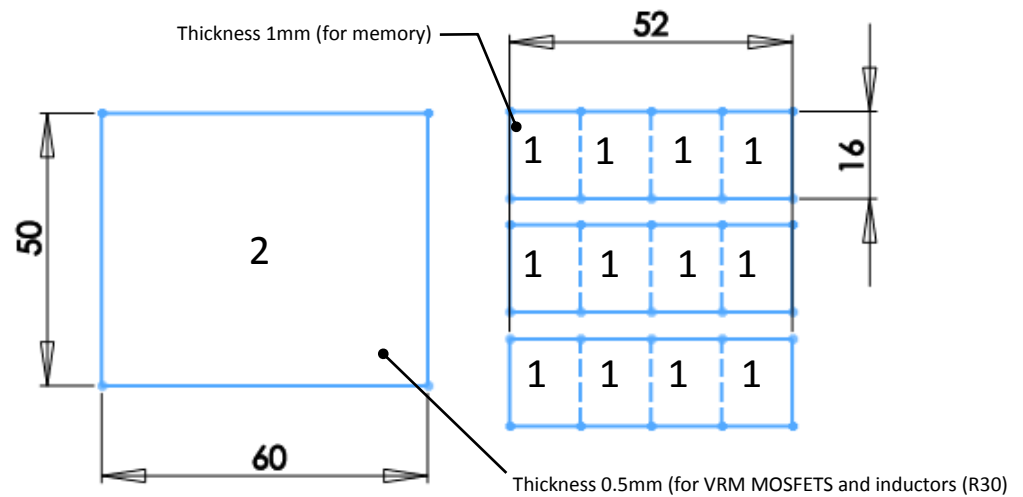

STEP 3: INSTALLING WATER BLOCK

1. PLACING THERMAL PADS ON PCB. Place thermal pads on chips so that numbers on chips match size of thermal pads. EKWB made sure users have more than enough pads to cover all surfaces that need to be covered to make block fully functional). EK recommends using small drops of electrically non-conductive (for example: Arctic Cooling MX-2™ or MX-4™) thermal grease on each phase regulator (that is being covered with thermal pad) in order to even further improve the thermal performance of the EK-FC570 GTX SE series water block.

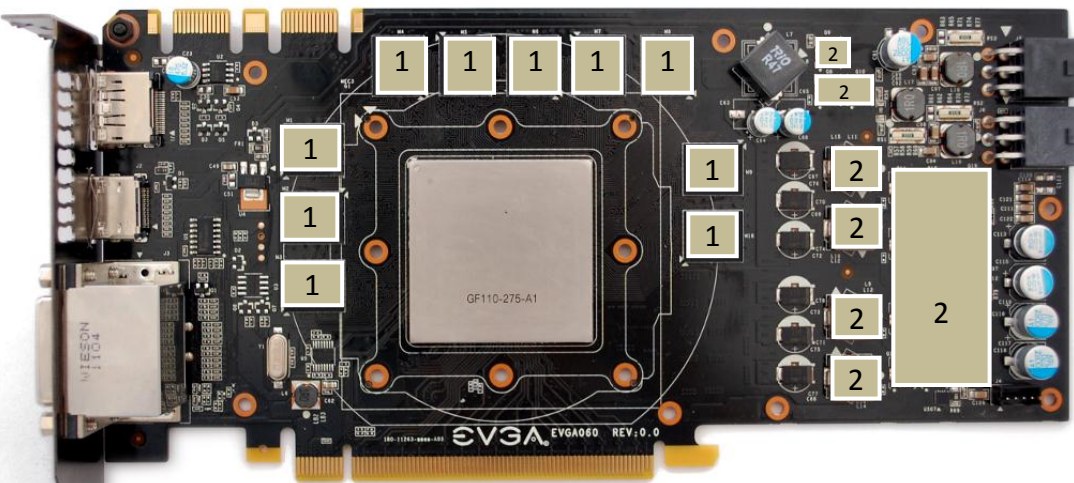

2. PLACING GPU REINFORCE PLATE ON PCB. Place metal reinforce and washer on PCB as shown on picture below and screw it in with enclosed M3x4 screws. Please use encased PVC washers under each screw. Make sure you use fasten screws equally and do not use too much force.

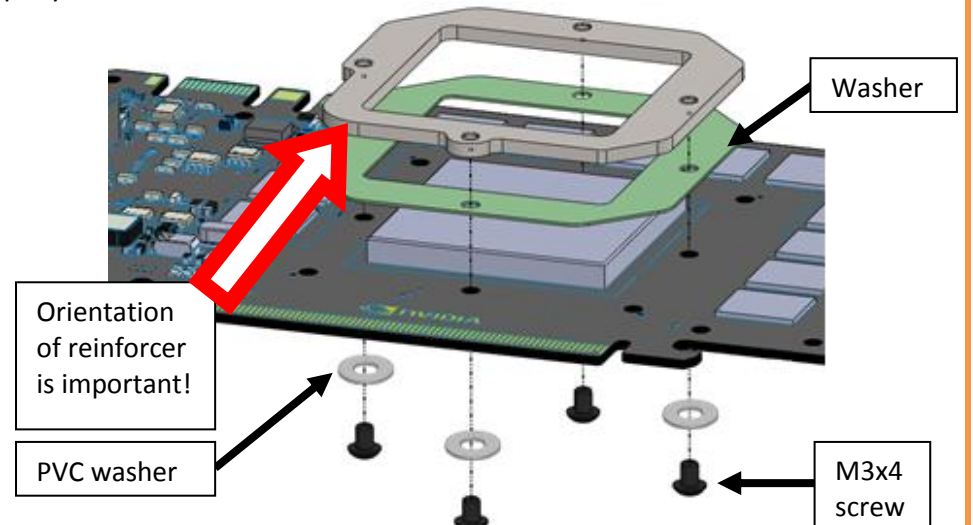

3. PLACING STANDOFFS ON BLOCK. Brass standoffs are obligatory in order to attach this water block to the printed circuit board of the graphics card. Please use the enclosed key to screw them to the copper base of the water block (pay attention not to scratch surface).

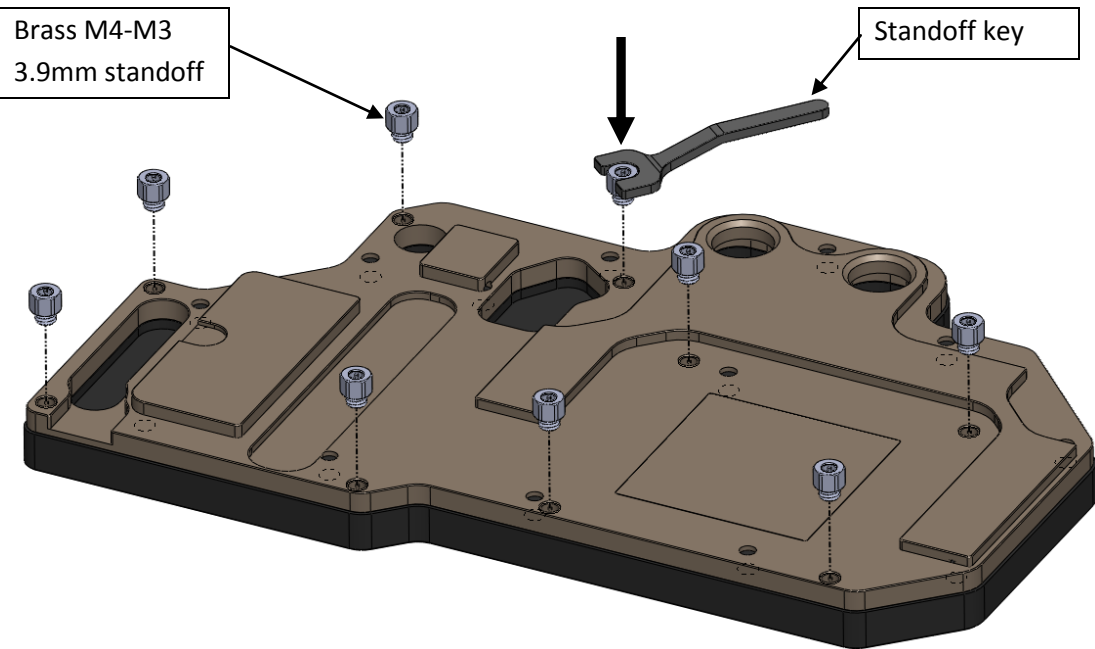

4. PLACING BLOCK TO GRAPHIC CARD. During this process please make sure you align holes on PCB with holes on block. Also pay attention not to use too much force by pressing block down to PCB. Chip dies are prone to cracking.

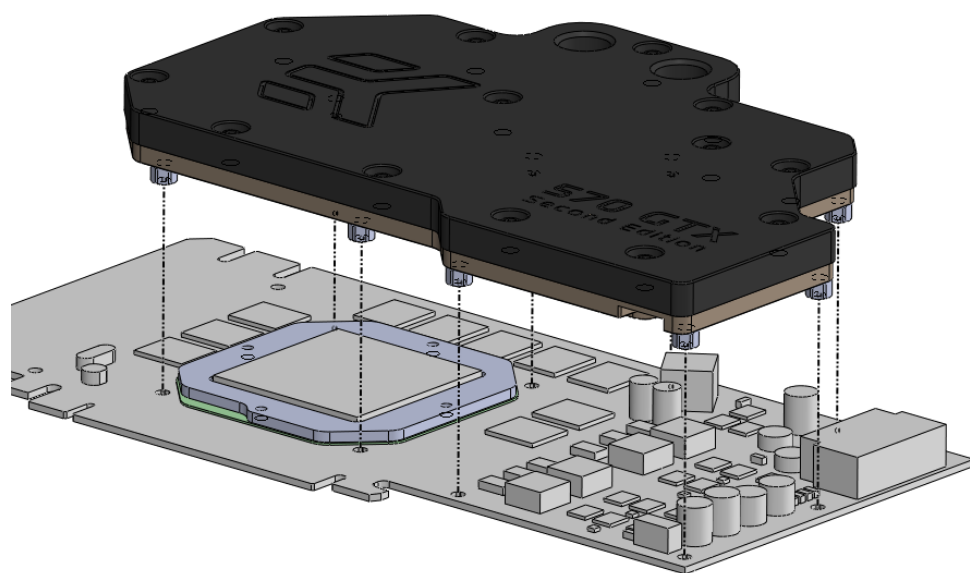

5. ATTACHING BLOCK TO GRAPHIC CARD. By using Philips screwdriver screw in enclosed M3x4 DIN7985 screws. EKWB recommends start screwing the screws around the GPU core and continue outwards.

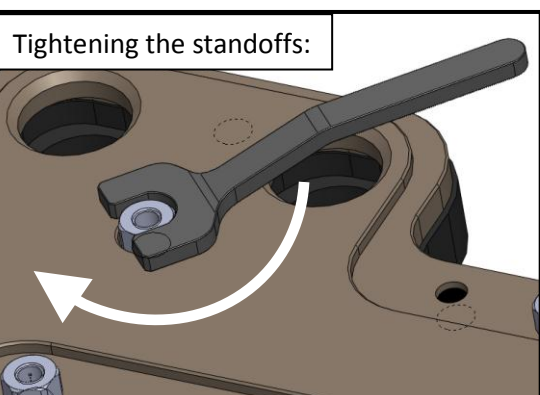
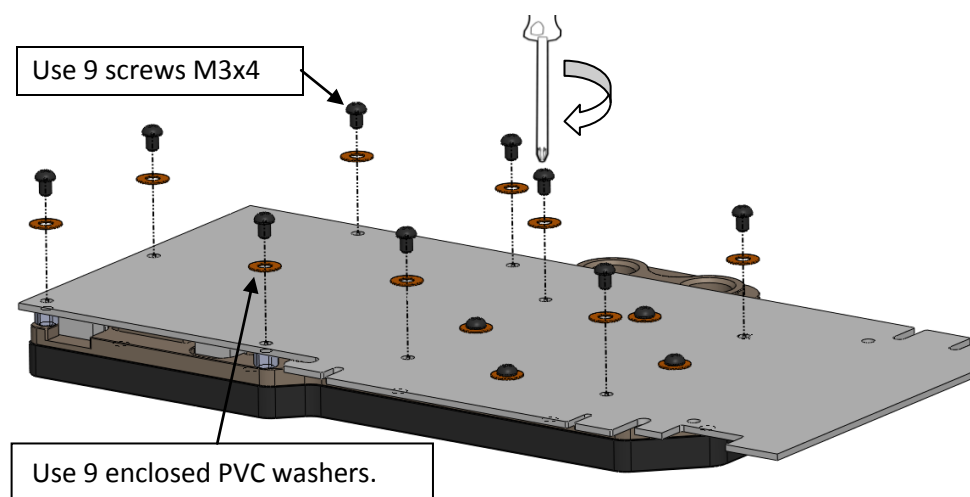

STEP 4: CHECKING FOR CONTACTS

Temporarily remove the water block to check for uniform surface contact between the block and the components. Note the pattern of contact on a piece of paper. Then repeat substeps in previous section to reattach the block. **In case you fail to obtain good contact, please check again your thermal pad thickness or contact our support service.**

STEP 5: SECURING I/O BRACKET

Use one M3x6 screw, one PVC washer and one M3 nut to secure the I/O (also known as PCI) bracket firmly to the circuit board. This will allow the computer chassis to carry the weight of the waterblock thus reducing the tension on the PCI-express slot. Tighten the screw with Philips screwdriver while holding the M3 nut with your thumbs firmly.

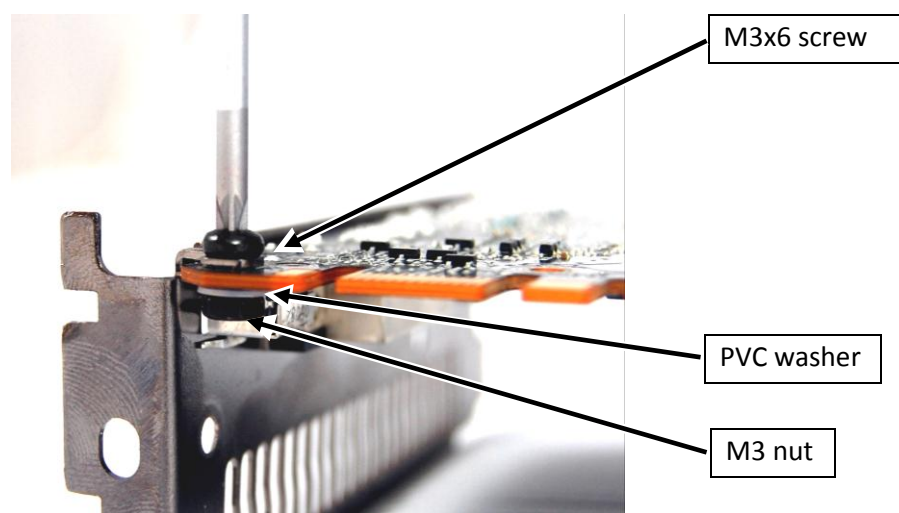

STEP 6: FITTING POSITIONING

Please use spacer only on copper base if you use fitting with G1/4 thread longer than 5mm (see sample picture). Screw in the fittings and plugs (use spacers on copper base in case you have fittings with G1/4 thread longer than 5mm). Use 6mm allen key to screw in and tighten new EK-Plug G1/4. Attach the liquid cooling tubes and connect the water-block(s) into the cooling circuit. EKWB recommends using EK-PSC fittings with the EK-FC570 GTX SE series water blocks. To ensure that the tubes are securely attached to the barb/fittings, please use hose clamps or an appropriate substitute. The use of an algacide is always recommended for any liquid cooling system. You can use any opening as an inlet/outlet port.

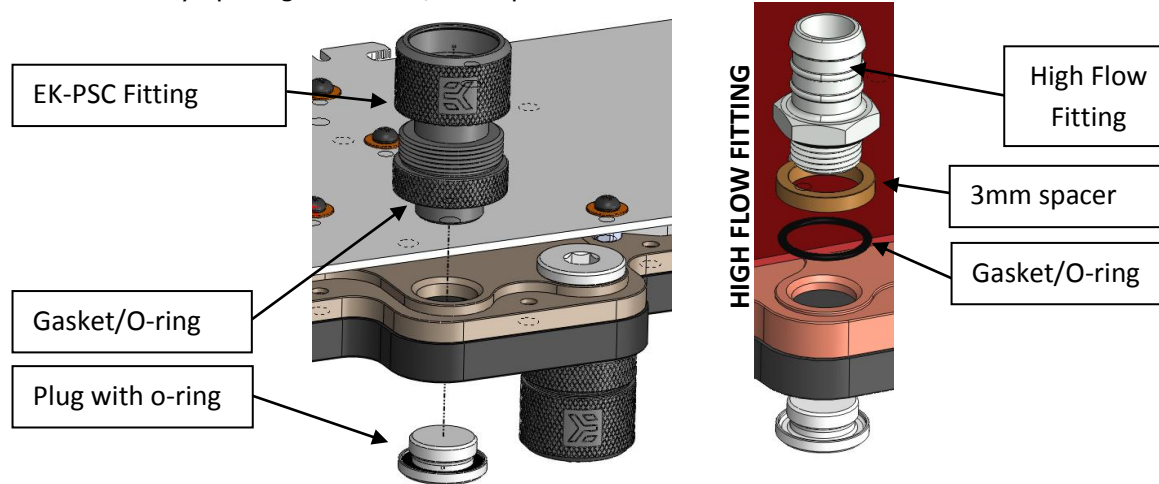

STEP 6: INSERTING CARD IN YOUR PC CASE

Carefully lift your card with installed block and insert it in your PC case. Please bear in mind that your card suddenly withstands extra weight thus again be very careful not to bend it or cause any other unneeded moves that might damage your card or block during installation.

REQUIRED TOOLS AND MOUNTING SCREWS:

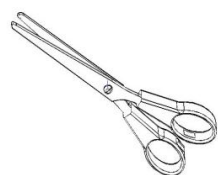

scissors



philips screwdriver



13 x screws M3x4 DIN7985



1 x M3x6 DIN7985



1 x M3 nut



14 x PVC washers

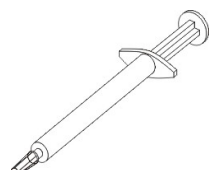

thermal grease