

EK-Quantum Vector² RE RTX 3080/90 ABP Set D-RGB

GPU WATER BLOCK WITH ACTIVE BACKPLATE

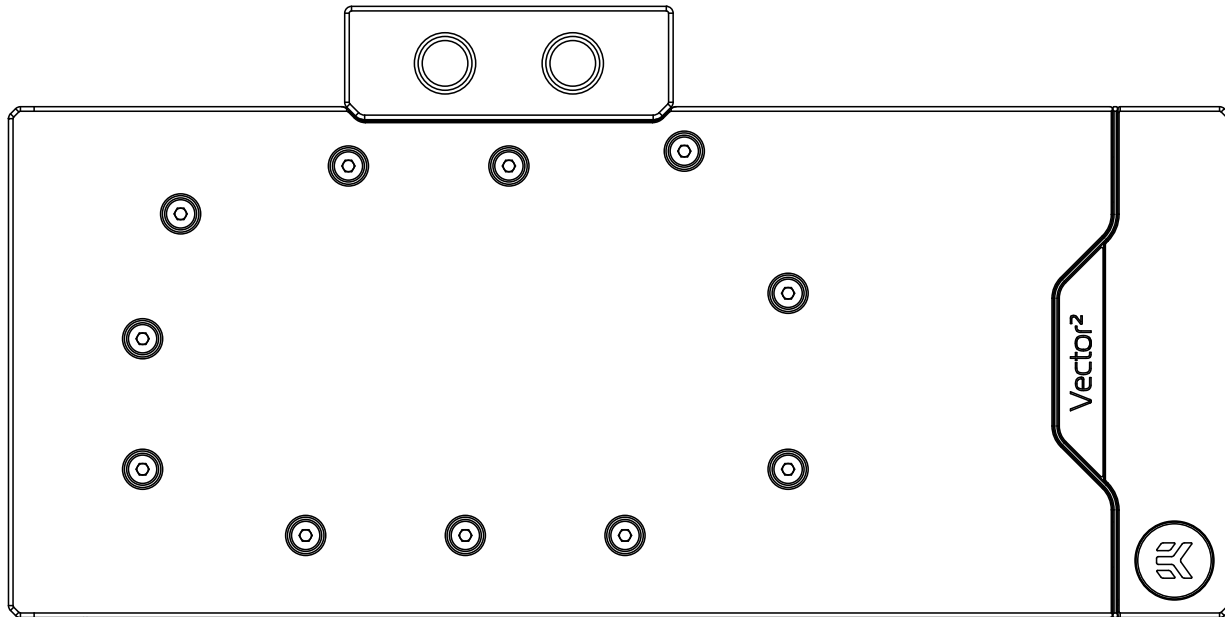

This product is intended for installation by expert users only. Please consult with a qualified technician. Improper installation may result in damage to your equipment. EK assumes no liability whatsoever, expressed or implied, for the use of this product or its installation. The following instructions are subject to change without notice. Please, read the manual carefully before starting the installation process. For updates, you can visit our official website www.ekwb.com.

Before you start using this product, please follow these basic guidelines:

Carefully read the manual before beginning with the installation process.

Remove your graphics card from the computer for the safest mounting process to prevent any possible damage to your GPU or its circuit board (PCB).

The EK Fittings require only a small amount of force to screw them firmly in place since the liquid seal is ensured by the rubber O-ring gaskets.

The use of corrosion inhibiting coolants is always recommended for liquid cooling systems and mandatory for nickel-plated water blocks!

Do not use pure distilled water! For best results, EK recommends the use of EK-CryoFuel coolants!

To reach optimal performance, make sure to thoroughly bleed the air out of your water block!

TABLE OF CONTENTS

BOX CONTENTS	4
WATER BLOCK DIMENSIONS	5
TECHNICAL SPECIFICATIONS AND WATER BLOCK PARTS (Nickel + Acetal)	6
TECHNICAL SPECIFICATIONS AND WATER BLOCK PARTS (Nickel + Plexi)	7
PREPARING THE GRAPHICS CARD	8
REMOVING THE STOCK COOLER	8
CLEANING THE PCB	8
PREPARING THE WATER BLOCK FOR INSTALATION	9
CUTTING AND PLACING THERMAL PADS	11
APPLYING THERMAL COMPOUND	12
ATTACHING THE GPU PCB ONTO THE WATER BLOCK	12
INSTALLING THE ACTIVE BACKPLATE	14
FITTINGS AND TUBING	17
INSERTING THE GRAPHICS CARD INTO THE CHASSIS	17
CONNECTING THE D-RGB LED STRIP	18
TESTING THE LOOP	18
WARRANTY	19
SUPPORT AND SERVICE	20
SOCIAL MEDIA	20

BOX CONTENTS

EAN: 104905

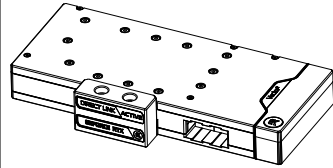

EK-Quantum Vector² RE RTX
3080/90 ABP Set D-RGB

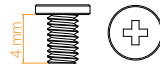

M2.5x4 AX1 Screw (8 pcs)

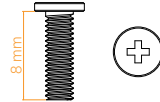

M2.5x8 AX1 Screw (1 pc)

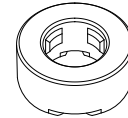

Standoff Ø4.5/2.5 (1 pc)

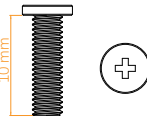

M3x10 AX1 Screw (1 pc)

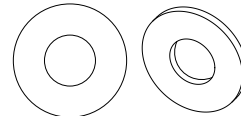

Polyamid Washer M2.5 0.5mm (8 pcs)

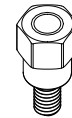

Standoff M2.5-M3 x 6.6mm (1 pc)

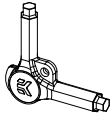

EK-Loop Multi Allen Key (1 pc)

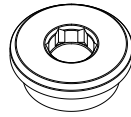

Quantum Plug (2 pcs)

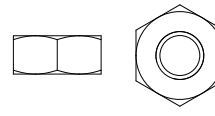

Nut M2.5 (2 pcs)

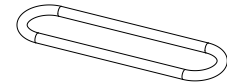

Terminal OR - Vector2 14x1 mm (2 pcs)

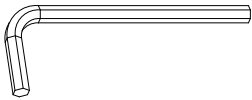

Allen Key 2.5 mm (1 pc)

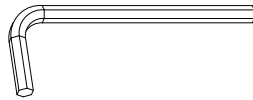

Allen Key 2 mm (1 pc)

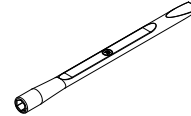

EK-Plug Out Spludger Tool (1 pc)

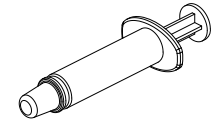

Thermal Grease (1 pc)

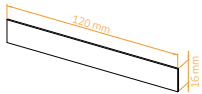

Thermal Pad F 1.0 mm (6 pcs)
(3830046996732)

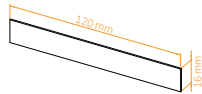

Thermal Pad F 1.5 mm (1 pc)
(3830046996749)

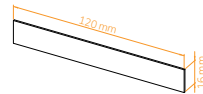

Thermal Pad F 2.0 mm (2 pcs)
(3830046996756)

EAN: 104549

WATER BLOCK DIMENSIONS

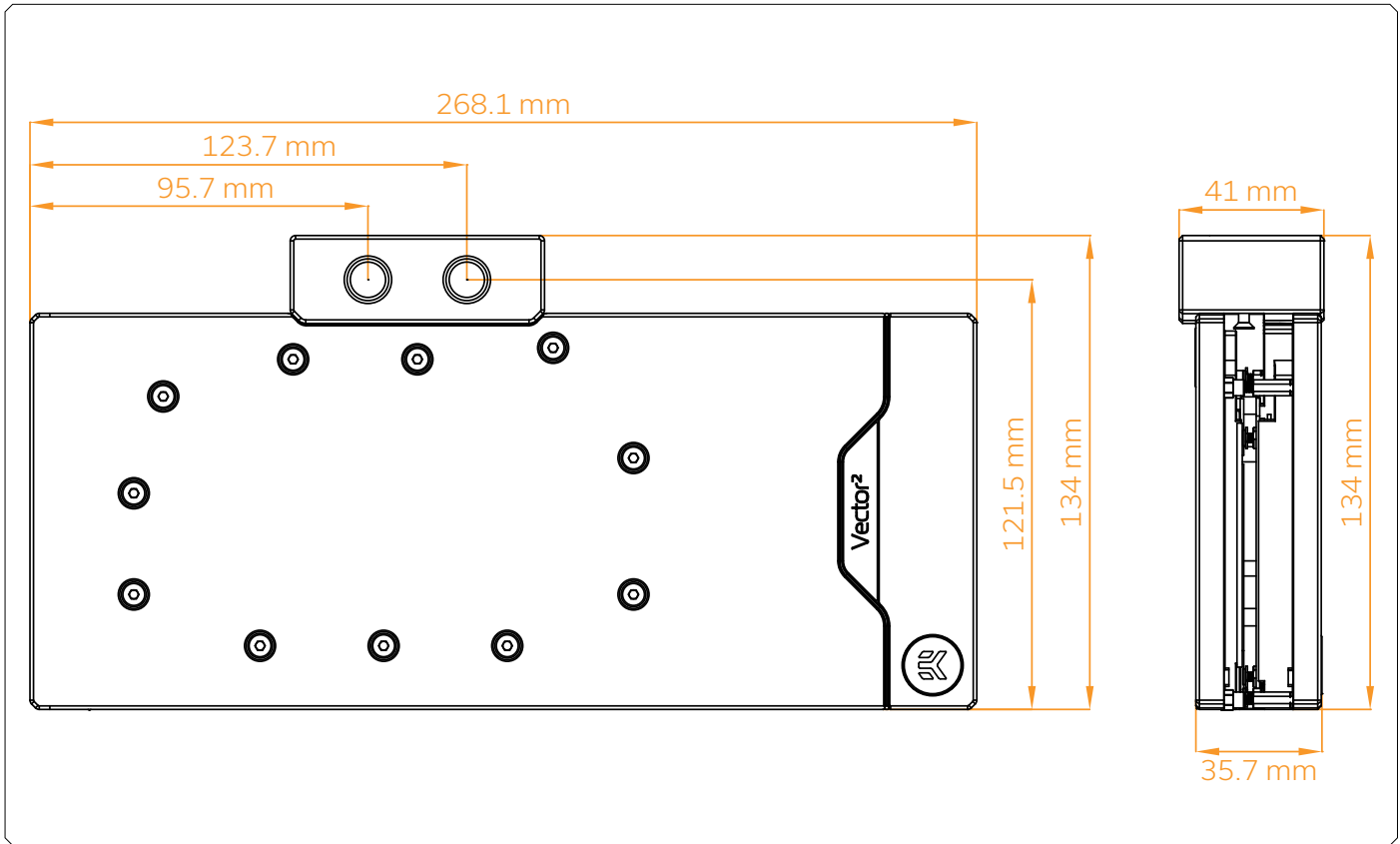

TECHNICAL SPECIFICATIONS AND WATER BLOCK PARTS (Nickel + Acetal)

EAN: 3831109854891

Technical Specification:

- Dimensions: (LxHxW) – 268.1x134x41 mm
- D-RGB (Addressable RGB) cable length: 500 mm
- D-RGB LED COUNT: 30
- D-RGB connector standard 3-pin (+5V, Data, Blocked, Ground)

Position	EAN	Description	Quantity
1	103944	Coldplate (Nickel)	1
2	103962	Plexi Insert	1
3	103946	TOP Acetal	1
4	103975	Bridge Plate	1
5	103987	Standoff M3.5-M2.5 x 3	5
6	103988	Standoff M4-M2.5 x 3	4
7	9024	Screw M4x10 DIN7984	10
8	9013	Screw M4x8 DIN7984	13
9	103986	Standoff M3.5-M2.5 x 11.3	3
10	104106	OR - 14x1	4
11	105163	Disc magnet 3x2	4
12	103942	Terminal Badge	1
13	8311	Screw M4x20 DIN7984	6
14	100663	EK Badge	2
15	104211	Mylar Sticker	2
16	8202	Screw M3x12 DIN7991	2
17	104104	TOP Acetal	1
18	104087	OR - AB	1
19	104085	Coldplate (Nickel)	1
20	104093	Standoff M2.5-M3 x 6.6	5
21	104105	Screw AX1 M3 x 10	5
22	104393	Terminal	1
23	104091	Front Plate	1
24	104395	Terminal Plate	1
25	104414	OR - Vector2	1
26	8201	Screw M3x10 DIN7991	2
27	104086	AB Terminal Badge	1
28	104100	Stand Out	1
29	104094	Light Guide	1
30	104295	LED Strip	1
31	103965	OR - Vector2	1
32	104899	PCB Cardboard	1

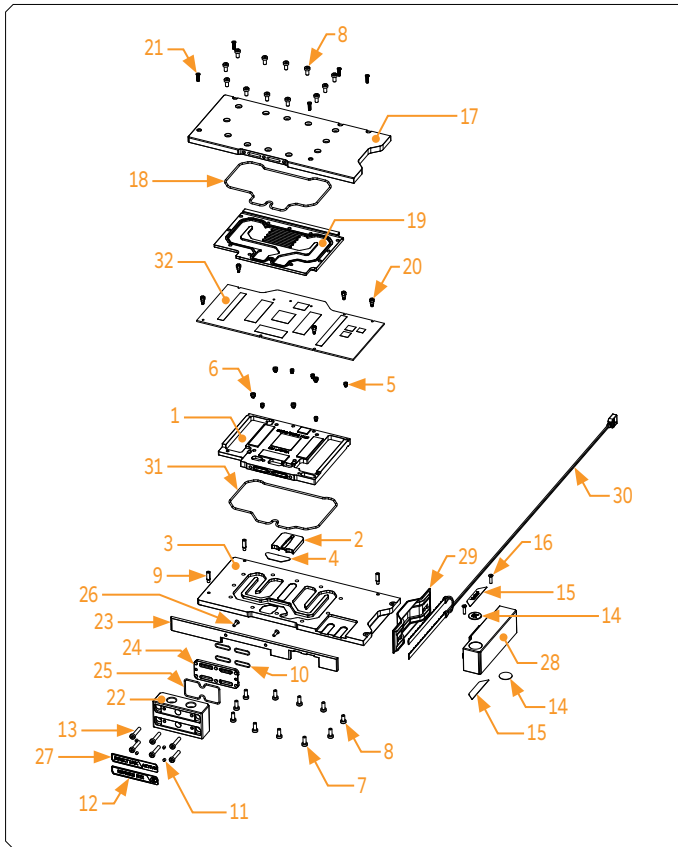

TECHNICAL SPECIFICATIONS AND WATER BLOCK PARTS (Nickel + Plexi)

EAN: 3831109854884

Technical Specification:

- Dimensions: (LxHxW) – 268.1x134x41 mm
- D-RGB (Addressable RGB) cable length: 500 mm
- D-RGB LED COUNT: 28
- D-RGB connector standard 3-pin (+5V, Data, Blocked, Ground)

Position	EAN	Description	Quantity
1	103944	Coldplate (Nickel)	1
2	103962	Plexi Insert	1
3	103945	TOP Plexi	1
4	103975	Bridge Plate	1
5	103987	Standoff M3.5-M2.5 x 3	5
6	103988	Standoff M4-M2.5 x 3	4
7	9024	Screw M4x10 DIN7984	10
8	9013	Screw M4x8 DIN7984	13
9	103986	Standoff M3.5-M2.5 x 11.3	3
10	104106	OR 14x1	4
11	105163	Disc magnet 3x2	4
12	103942	Terminal Badge	1
13	8311	Screw M4x20 DIN7984	6
14	8208	Screw M3x8 7991DIN	2
15	100663	EK Badge	2
16	103964	Mylar Sticker	2
17	103950	LED Extrusion	2
18	104103	TOP Plexi	1
19	104087	OR - Vector2	1
20	104085	AB Coldplate (Nickel)	1
21	104093	Standoff M2.5-M3 x 6.6	5
22	104105	Screw AX1 M3 x 10	5
23	104097	Stand Out	1
24	101556	LED Strip	2
25	104393	Terminal	1
26	104091	Front Plate	1
27	104395	Terminal Plate	1
28	104414	OR - AB Terminal	1
29	8201	Screw M3x10 DIN7991	2
30	104086	Terminal Badge	1
31	103965	OR - Vector2	1
32	104899	PCB Cardboard	1

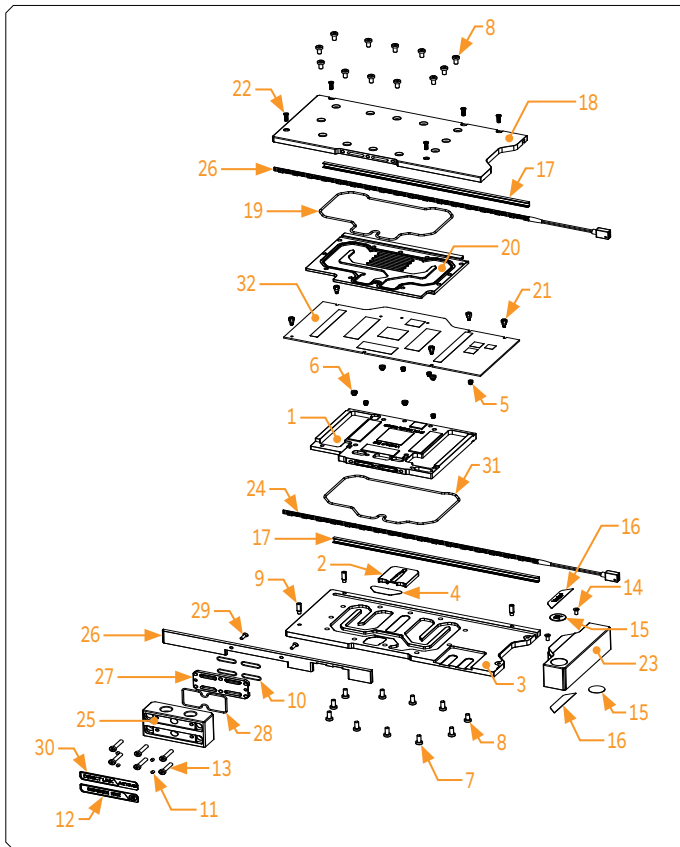

PREPARING THE GRAPHICS CARD

STEP 1 REMOVING THE STOCK COOLER

Place your graphics card on the flat surface and carefully remove the stock cooler. Do not forget to unplug all the LED and fan connectors. Pay attention to the following steps in order to install the EK-Quantum Vector² RE RTX 3080/90 ABP Set D-RGB water block onto the graphics card.



Always remove the stock cooler slowly - it might be firmly glued to the PCB via thermal pads.

STEP 2 CLEANING THE PCB

Wipe off the remains of the original thermal compound using a nonabrasive cloth or Q-tip, as shown in the sample image, until the components and the circuit board are completely clean. EK recommends the use of denatured alcohol for removing TIM leftovers. After that, remove all remaining stock thermal pads from the PCB.

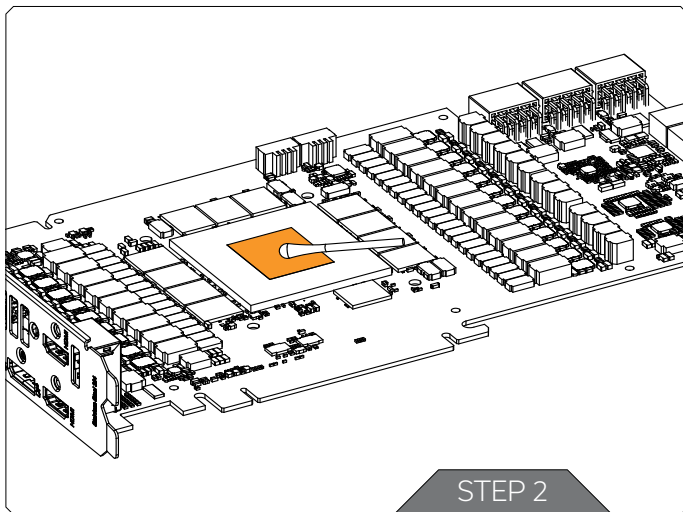

PREPARING THE WATER BLOCK FOR INSTALATION

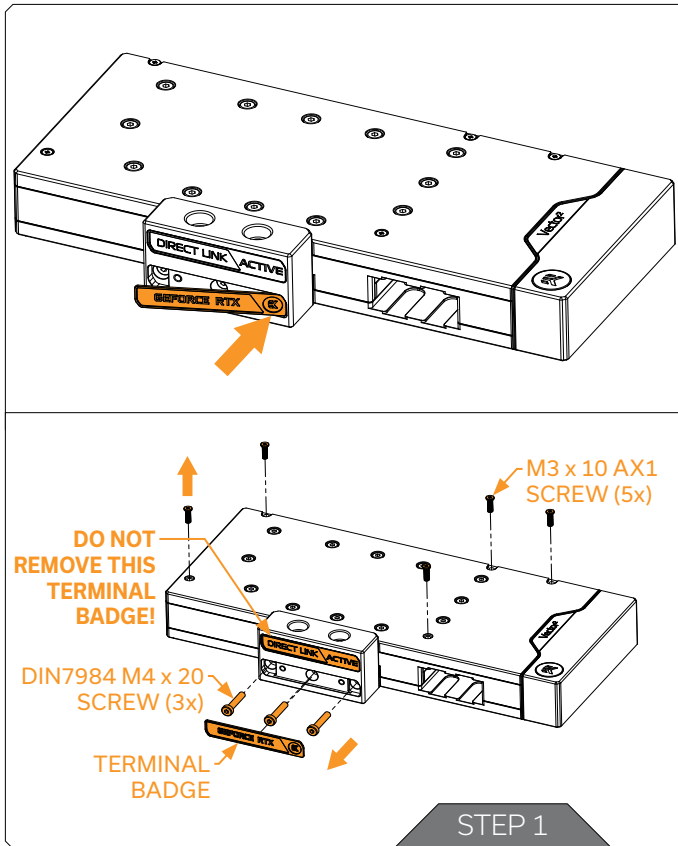

Your water block set includes the water block and the active backplate.

STEP 1

First, remove the terminal badge attached to the terminal via two magnets. There are three (3) DIN7984 M4x20 screws under the badge. Unscrew all three. Unscrew five (5) AX1 M3x10 screws as shown in the image.

DO NOT REMOVE THE UPPER TERMINAL BADGE!

For this step you will need:

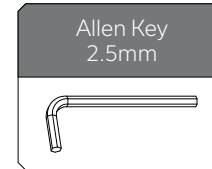
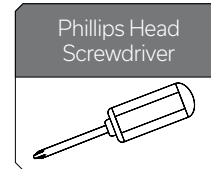

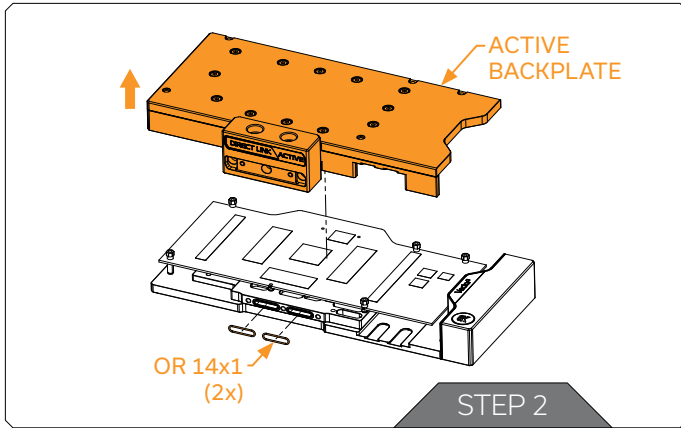

STEP 2

Carefully remove the complete active backplate with the terminal. Remove two (2) O-rings OR 14x1.

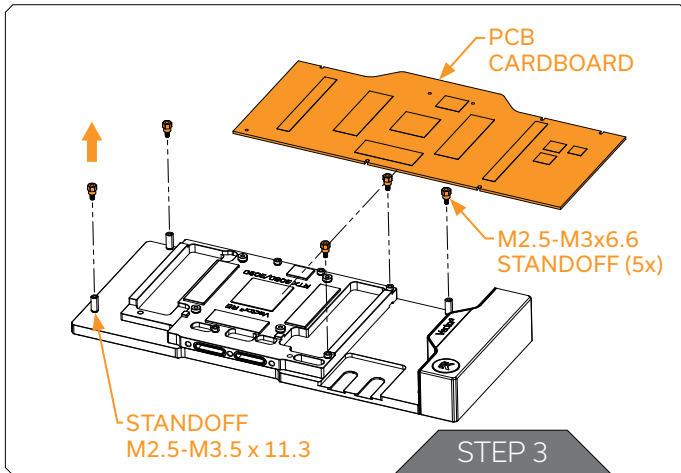

STEP 3

Unscrew 5 (five) M2.5-M3x6.6 standoffs using the included tool (EK-Plug out Spludger Tool). Remove the PCB cardboard (Printed Circuit Board cardboard). **Do not unscrew the M3.5-M2.5x11.3 standoffs!** If the M3.5-M2.5x11.3 standoff unscrews, carefully tighten it with a 4mm wrench. Do not use moment higher than 0.6 Nm.

For this step, you will need:

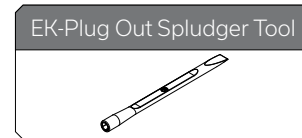

CUTTING AND PLACING THERMAL PADS

Thermal Pad F - 1.0 mm (120 x 16 mm)



STEP 1

STEP 1



CAUTION: You must remove the protective foil from both sides of the thermal pad before installation.

Replacement thermal pads:

Thermal Pad F 1.0mm - (120 x 16mm) EAN: 3830046996732

Your EK-Quantum Vector² RE RTX 3080/90 ABP Set D-RGB block comes with thermal pads that have to be cut into smaller pieces to cover all the VRM components. EK made sure to provide you with more than an adequate quantity of thermal pads to complete this step.

For this step, you will need:

Scissors

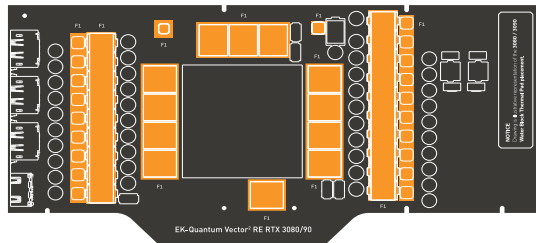
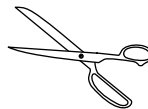

F1 Thermal Pad - 120 x 16 x 1.0 mm

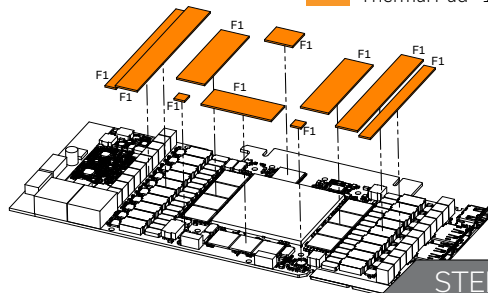

STEP 2

STEP 2

The cardboard is printed in scale 1:1. Cut the thermal pads according to the size specifications printed on the PCB cardboard. Once cut to size, thermal pads should be placed on the GPU PCB, as shown in the image. Be careful to choose the right thermal pad thickness. Thermal pads of three different thickness levels (1 mm, 1.5 mm, 2 mm) are included.

APPLYING THERMAL COMPOUND

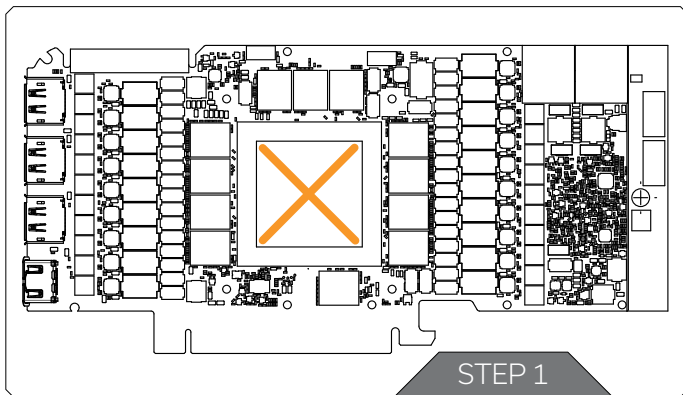

STEP 1

Apply the enclosed EK-TIM Ectotherm thermal grease (thermal compound) on the GPU heat spreader - IHS - as shown in the image. The layer of the thermal compound must be thin and evenly spread over the entire surface of the IHS.



The excessive or uneven application of thermal grease may lead to poor performance!

For this step, you will need:

Thermal Grease

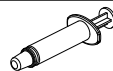

ATTACHING THE GPU PCB ONTO THE WATER BLOCK

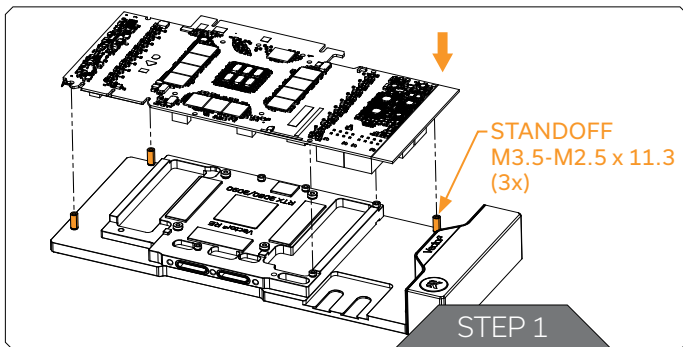

Before attaching the PCB on the Water Block, make sure all the Thermal Pads are placed correctly!

STEP 1

Place the shown part of the block on a flat surface. Place the PCB with thermal pads on the M3.5-M2.5 x 11.3 standoffs and make sure all holes are aligned.

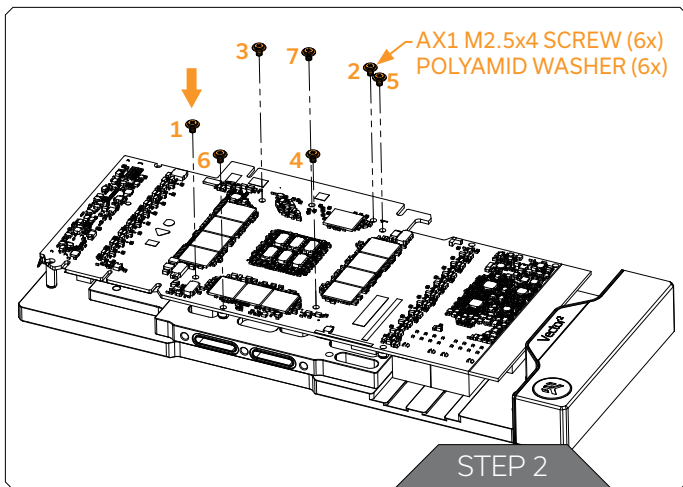

STEP 2

After placing a PCB on the water block, use AX1 M2.5x4 screws and polyamide washers to tighten the PCB on the water block.

Do not forget to put polyamide washers between the PCB and screws! Tighten the screws according to the number order shown in the image!

Do not use excessive force!

Do not use moment higher than 0.6 Nm!

For this step, you will need:

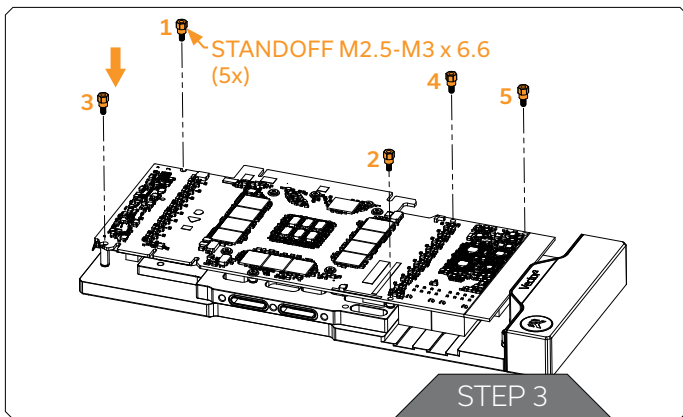
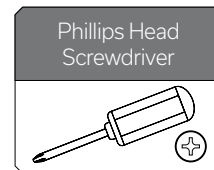
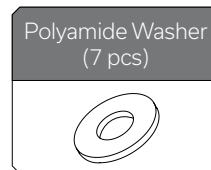
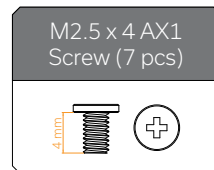

STEP 3

Position the M2.5-M3 x 6.6 standoffs with holes of M3.5-M2.5 x 11.3 and M3.5-M2.5 x 3 standoffs, as shown in the image. Tighten them evenly with the EK-Plug-Out Spludger Tool (EAN 104299).

Tighten the screws according to the number order shown in the image!

Do not use excessive force!

Do not use moment higher than 0.6 Nm!

For this step, you will need:

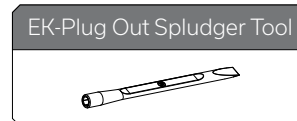

INSTALLING THE ACTIVE BACKPLATE

Thermal Pad F - 1.0 mm (120 x 16 mm)



Thermal Pad F - 1.5 mm (120 x 16 mm)

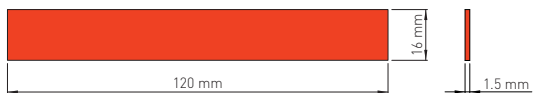

Thermal Pad F - 2.0 mm (120 x 16 mm)

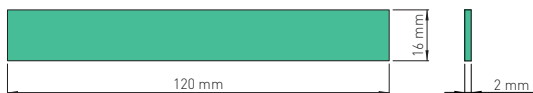

STEP 1

STEP 1



CAUTION: You must remove the protective foil from both sides of the thermal pad before installation.

Replacement thermal pads:

Thermal Pad F 1.0mm - (120 x 16mm) EAN: 3830046996732

Thermal Pad F 1.5mm - (120 x 16mm) EAN: 3830046996749

Thermal Pad F 2.0mm - (120 x 16mm) EAN: 3830046996756

After attaching the GPU PCB, few more thermal pads need to be placed on the back side of the GPU PCB. Once cut to size, thermal pads should be placed on the GPU PCB, as shown on image below (STEP 2). EK made sure to provide you with more than an adequate quantity of thermal pads to complete this Step.

For this step, you will need:

Scissors

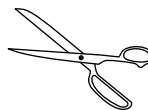

3080/3080Ti

- F1 Thermal Pad - 120 x 16 x 1.0 mm
- F1.5 Thermal Pad - 120 x 16 x 1.5 mm
- F2 Thermal Pad - 120 x 16 x 2.0 mm

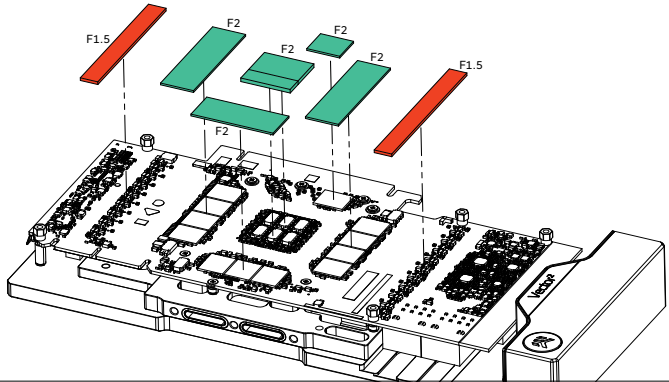

STEP 2



CAUTION: You must remove the protective foil from both sides of the thermal pad before installation.

3090

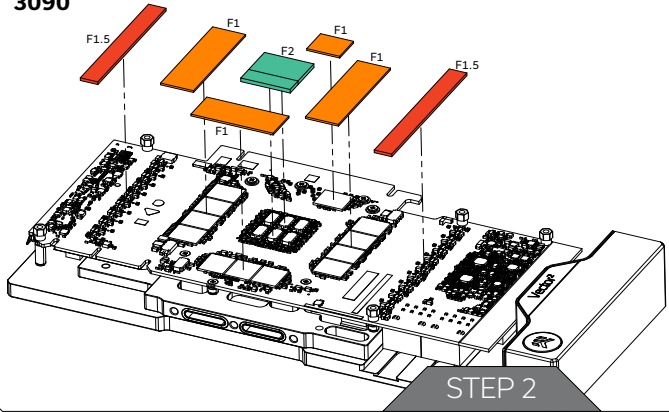

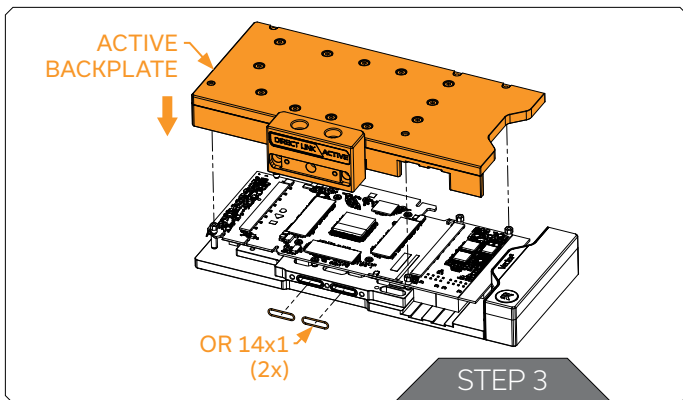

Before attaching the Active Backplate on the PCB, make sure all the Thermal Pads are placed correctly!

STEP 3

First, put two O-rings 14x1 into slots on the Coldplate. Then carefully place active backplate on standoffs as shown in the image. While putting the active backplate on the PCB, make sure the O-rings stay in the slots.

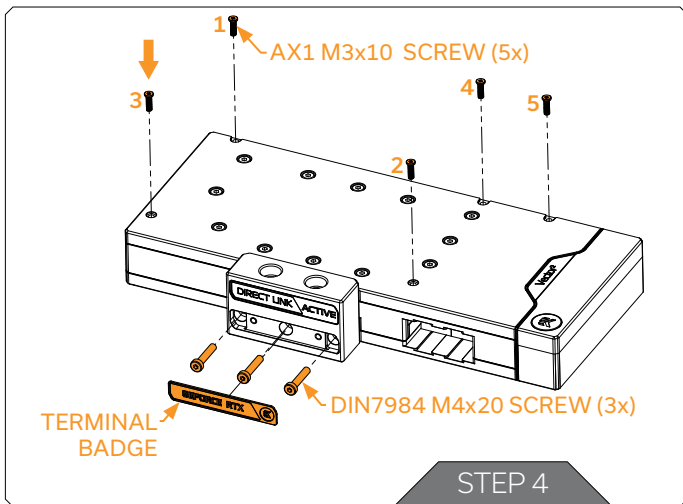

STEP 4

Place five (5) M3x10 AX1 screws into the water block standoffs and tighten them using Philips head screwdriver (as shown in the image).

After attaching the AX1 Screws, three (3) terminal screws M4x20DIN7984 must be placed in the Terminal and tightened using Allen Key 2.5mm.

Put the Terminal badge onto the terminal magnets.

Pay attention not to use too much force when tightening the active backplate down to the GPU PCB.

For this step, you will need:

Phillips Head Screwdriver

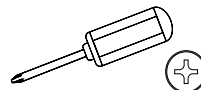

Allen Key 2.5mm



FITTINGS AND TUBING

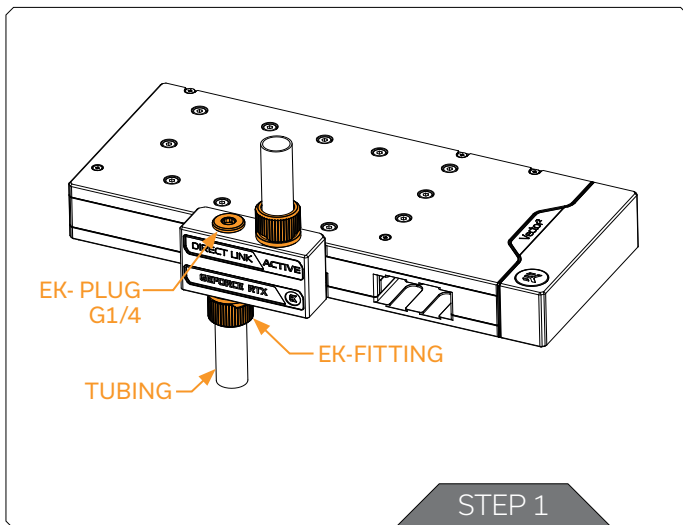

STEP 1

Screw-in two (2) G1/4 threaded male fittings. Attach the liquid cooling tubes and connect the water block to the cooling loop.



Do not forget to plug the remaining two openings using the enclosed EK-Plug G1/4 or its equivalent.

EK recommends using EK fittings with all EK water blocks.



CAUTION: When using connectors other than EK fittings, pay special attention to the length of the fittings' male G1/4" thread - 5mm is the maximum G1/4" thread length allowed!

For this step, you will need:

EK-Loop Multi Allen Key

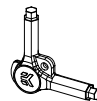

INSERTING THE GRAPHICS CARD INTO THE CHASSIS

Carefully lift your graphics card with the installed water block and insert it into your PC's motherboard PCI express expansion slot. Please keep in mind that your graphics card is heavier than before it was equipped with the water block.



You need to be very careful when handling the graphics card. Avoid all unnecessary manipulation of the water block assembly that might damage your card or water block.

CONNECTING THE D-RGB LED STRIP

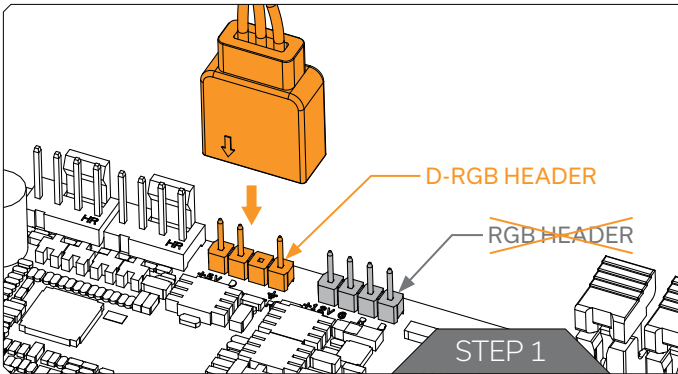

STEP 1

Plug the **3-pin connector** of the distribution plate D-RGB LED light to the **D-RGB HEADER** on the motherboard. The LED will work if the pin layout on the header is as follows: **+5V, Digital, Empty, Ground**.



Incorrect installation or installation to a wrong header can damage the LED strip or the header itself!

TESTING THE LOOP

To make sure the installation of EK components was successful, we recommend performing a 24-hour leak test. When your loop is complete and filled with coolant, connect the pump to a PSU outside your system. Make sure all the other components are not connected to a power source. Turn on the PSU and let the pump run continuously. It is normal for the coolant level to drop during this process as air accumulates in the distribution plate. Inspect all parts of the loop, and if there is any coolant leak, fix the issue and repeat the testing process until there are no coolant leaks. In order to prevent any damage, ensure that all hardware is dry before the system is powered back on.

WARRANTY

Our products are warranted against defects of materials and quality for a period of 24 months, starting with the date of delivery to the end-user. During this period, products will be repaired or have parts replaced at our discretion, provided that 1) the product is returned to the agent from whom it was purchased; 2) the product has been purchased by the end-user and has not been used for commercial purposes; 3) the product has not been misused, handled carelessly, or used in a manner other than the way described in the instruction manual. This warranty does not confer rights other than those expressly set out above and does not cover any claims for consequential loss or damage. This warranty is offered as an extra benefit and does not affect your statutory rights as a consumer. This warranty is voided if the product comes in contact with aggressive UV additives or other improper liquids. EK water blocks are sealed with a warranty-voiding circular label, proving the water block has withstood a pressure leak test. Removing the label will void the leak-free warranty, but not the warranty of the product itself. Any other RMA issues can be reported to EK Customer Support at www.ekwb.com/support for further analysis.

SUPPORT AND SERVICE

In case you need assistance or wish to order spare parts or a new mounting mechanism, please contact:

<https://www.ekwb.com/customer-support/>

For spare parts orders, refer to the page with "TECHNICAL SPECIFICATIONS AND WATER BLOCK PARTS" where you can find the EAN number of each part you might need.

Include the EAN number with quantity in your request. Mounting Mechanism EAN can be found under "BOX CONTENTS"

Thermal pads are readily available in the EK shop

SOCIAL MEDIA

 EKWaterBlocks

 @EKWaterBlocks

 ekwaterblocks

 EKWBofficial

 ekwaterblocks

