

# EK-Nucleus AIO CR360 Vision D-RGB / CR240 Vision D-RGB

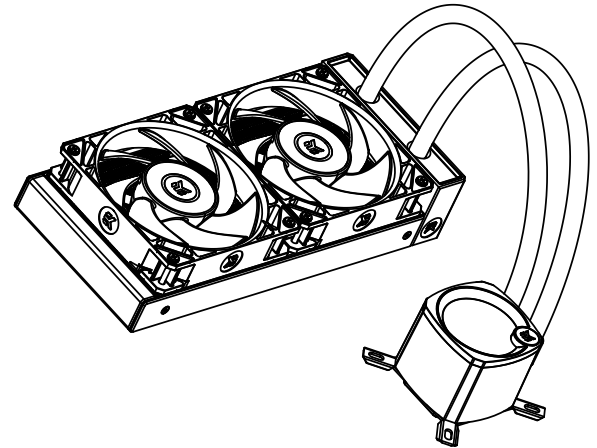

**To ensure safe and easy installation, please carefully read this manual before beginning the installation process!**

**Compatible with:**  
Intel Socket 115X/1200/1700/20xx CPUs  
AMD Socket AM4/AM5 CPU

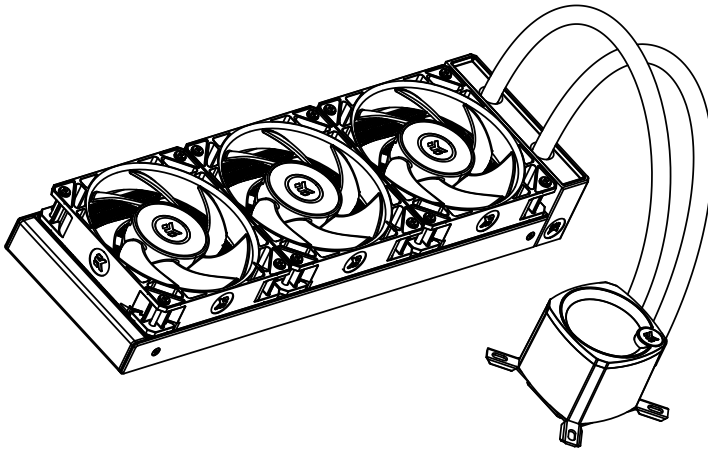

## TABLE OF CONTENTS

1. SAFETY PRECAUTIONS.....	4
2. SPECIFICATIONS.....	4
3. ENCLOSED IN THIS PACKAGE.....	5
ACCESSORY BOX.....	5
4. INSTALLATION – INTEL LGA 115X/1200/1700 SOCKET.....	6
STEP 1: REMOVING THE MOTHERBOARD.....	6
STEP 2: ATTACHING THE BACKPLATE TO THE MOTHERBOARD.....	6
STEP 3: ATTACHING MOUNTING SCREWS.....	6
STEP 4: INSTALLING THE FANS TO THE RADIATOR.....	6
STEP 5: REMOVING THE COLD-PLATE PROTECTIVE COVER.....	6
STEP 6: MOUNTING-BRACKETS INSTALLATION.....	6
STEP 7: PUMP UNIT INSTALLATION.....	6
STEP 8: INSTALLING THE ASSEMBLY OF FANS AND RADIATOR INTO A PC CASE.....	7
STEP 9: PUMP – CONNECTING CABLES.....	7
STEP 10: FANS – CONNECTING CABLES.....	8
STEP 11: PUMP TOP ORIENTATION.....	8
OPTIONAL STEP 1! APPLYING THE THERMAL COMPOUND.....	8
OPTIONAL STEP 2! CHANGING FAN CONTROL.....	8
5. INSTALLATION – INTEL LGA 20XX SOCKET.....	9
STEP 1: ATTACHING MOUNTING SCREWS (LGA 20XX).....	9
6. INSTALLATION – AMD AM4/AM5 SOCKET.....	9
STEP 1: REMOVING OF THE ORIGINAL PLASTIC HOLD-DOWN CLAMPS (AMD).....	9
STEP 2: ATTACHING MOUNTING SCREWS (AMD).....	9
STEP 3: INSTALLING THE FANS TO THE RADIATOR (AMD).....	9
STEP 4: REMOVING THE COLD-PLATE PROTECTIVE COVER (AMD).....	10
STEP 5: MOUNTING-BRACKETS INSTALLATION (AMD).....	10
STEP 6: PUMP UNIT INSTALLATION (AMD).....	10
STEP 7: INSTALLING THE ASSEMBLY OF FANS AND RADIATOR INTO A PC CASE (AMD).....	10
STEP 8: PUMP – CONNECTING CABLES (AMD).....	11
STEP 9: FANS – CONNECTING CABLES (AMD).....	11
STEP 10: PUMP TOP ORIENTATION (AMD).....	12
OPTIONAL STEP 1! APPLYING THE THERMAL COMPOUND.....	12
OPTIONAL STEP 2! CHANGING FAN CONTROL.....	12
7. DISPLAY SETUP & EK-CONNECT INSTRUCTIONS.....	12
GENERAL.....	12
THE EK-NUCLEUS AIO VISION DISPLAY SETUP.....	13
8. GENERAL SAFETY WARNINGS.....	13
9. SUPPORT AND SERVICE.....	13
10. SOCIAL MEDIA.....	13

Please follow the instructions in this manual for proper installation. Improper installation may result in damage to your equipment. EK Water Blocks assumes no liability whatsoever, expressed or implied, for the use of these products, nor their installation. The following instructions are subject to change without notice. Please visit our website at [www.ekwb.com](http://www.ekwb.com) for updates.

## 1. SAFETY PRECAUTIONS

1. Keep and store the product away from the reach of children.
2. Check the component list and condition of the product before installation. If there is any problem, contact the shop where you purchased the product to get a replacement or refund.
3. EKWB d.o.o. is not responsible for any damages due to external causes, including but not limited to, improper use, problems with electrical power, accident, neglect, alteration, repair, improper installation, and improper testing.
4. CPU and motherboard are subject to damage if the product is incorrectly installed.
5. Excessive force exerted on the fan may cause damage to the fan and/or system.
6. This product is a CPU liquid cooling solution kit, composed of individual, original EKWB parts. Combining this liquid cooling unit with parts, other than EK Water Blocks products, may lead to warranty loss.
7. Product design and specifications may be revised to improve quality and performance.
8. You must not run the pump below 20% RPM. The pump must stay within a 20-100% PWM duty cycle at all times. We recommend always running the pump at 100%. (For help on how to control the PWM, please refer to your motherboard instructions.)

## 2. SPECIFICATIONS

Model		<b>EK-Nucleus AIO CR240 Vision D-RGB</b>	<b>EK-Nucleus AIO CR360 Vision D-RGB</b>
Radiator	Dimensions	281x124x27 mm	400x124x27 mm
	Fin material	Al	Al
Fan	Dimensions	120x120x25 mm (2x)	120x120x25 mm (3x)
	Speed	550-2300 RPM ±10% (PWM: 20-100%)	550-2300 RPM ±10% (PWM: 20-100%)
	Air Flow	72 CFM	72 CFM
	Life Expectancy	70.000 hours	70.000 hours
	Noise Level	36 dB	36 dB
	Bearing Type	FDB bearing	FDB bearing
	Fan Connector	4Pin	4Pin
	Fan Rated Voltage	12V	12V
	D-RGB Connector	3Pin	3Pin
Pump	D-RGB Rated Voltage	5V	5V
	Dimensions (mm)	82.3x69.2x61.6 mm	82.3x69.2x61.6 mm
	RPM	3100 RPM ±10% (PWM: 20-100%)	3100 RPM ±10% (PWM: 20-100%)
	Life Expectancy	70.000 hours	70.000 hours
	Noise Level	18.5 dB	18.5 dB
Display	Input Current	0.37 ±10% A	0.37 ±10% A
	Diameter (mm)	53mm	53mm
	Display type	IPS	IPS
	Frame rate	30 FPS	30 FPS
	Resolution	480x480	480x480
Color depth	24-bit	24-bit	

### 3. ENCLOSED IN THIS PACKAGE

EK-Nucleus AIO CR240 Vision D-RGB /  
EK-Nucleus AIO CR360 Vision D-RGB  
(1x)



EK-FPT FAN 120 D-RGB Full Pressure Technology  
(2x / 3x - number of fans depends on the AIO version)



Extension cable 500mm



Accessory box  
(1x)

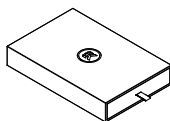

User Manual  
(1x)

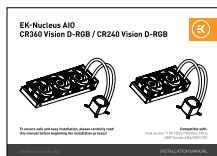

### ACCESSORY BOX

Phillips Head Screw UNC 6-32 x 30mm (4 mm thread length) 8x / 12x		Phillips Head Screw UNC 6-32 x 6mm 8x / 12x	
Phillips Head Screw UNC 6-32 x 34mm 8x / 12x		Mounting Plate Phillips Head M3x4mm (for the installation of mounting brackets) 4x	
Mounting thumb screw for Intel LGA 115x/LGA1200/ LGA1700/AMD AM4/AM5 socket 4x		Mounting thumb screw for Intel LGA 20XX socket 4x	
Thumb nut (Intel /AMD) 4x		Spring 4x	
Intel LGA 115x/1200 Backplate 1x		Intel LGA 1700 Backplate 1x	
Intel mounting bracket 1x		AMD mounting bracket 1x	
Tube of Thermal Paste 1x		Mounting Screw Tool 1x	

## 4. INSTALLATION – INTEL LGA 115X/1200/1700 SOCKET

### STEP 1: REMOVING THE MOTHERBOARD

If your PC case doesn't have a cutout from the bottom CPU side of the motherboard, you will first need to remove the motherboard from your computer.

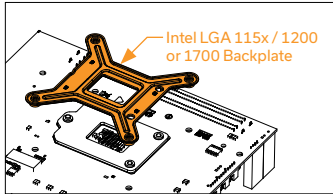

### STEP 2: ATTACHING THE BACKPLATE TO THE MOTHERBOARD

Install the Intel backplate for LGA 115x/1200/1700 socket to the back of your motherboard. Choose the right backplate depending on which chipset you are using. Align the holes on the motherboard with the holes on the backplate.

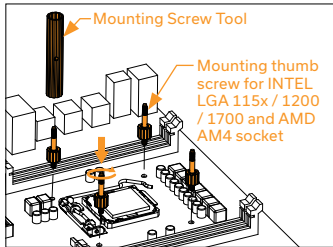

### STEP 3: ATTACHING MOUNTING SCREWS

Install 4x mounting thumb screws through your motherboard to the backplate. The screws can be installed by using Mounting Screw Tool. Do not use other tools, because you may damage the motherboard. (i.e. pliers).

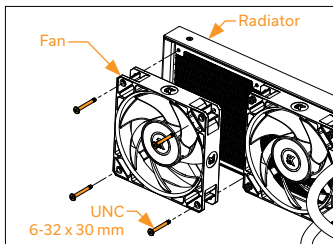

### STEP 4: INSTALLING THE FANS TO THE RADIATOR

Assemble the fans (2x - 3x - depending on the AIO version) to the radiator with the UNC 6-32 x 30mm screws.

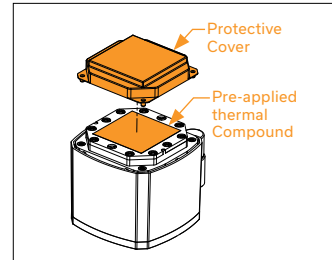

### STEP 5: REMOVING THE COLD-PLATE PROTECTIVE COVER

Remove the protective cover from the backside of the pump unit. It is there only to prevent damage to the cold-plate and the pre-applied thermal compound that is on the cold-plate.

When removing the protective cover and proceeding with installation, be careful not to touch or damage the pre-applied thermal compound.

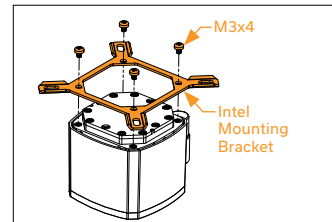

### STEP 6: MOUNTING-BRACKETS INSTALLATION

Use 4x M3x4 screws to install Intel bracket on the pump unit.

Be careful not to touch or damage the pre-applied thermal compound.

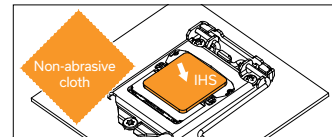

### STEP 7: PUMP UNIT INSTALLATION

Wipe the CPU's contact surface (using a non-abrasive cloth or a Q-tip as shown in the sample image).

Align the pump unit over the mounting screws and CPU as shown in the picture.

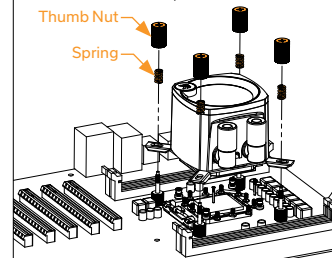

Place the enclosed compression springs and thumb nuts over the mounting screws (4x). Start fastening two thumb nuts at a time, preferably in a cross pattern, and do not tighten them fully until all of them are partially screwed in.

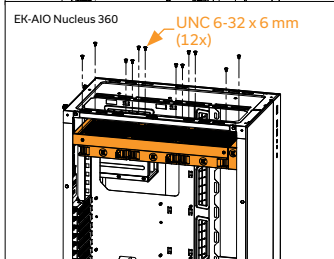
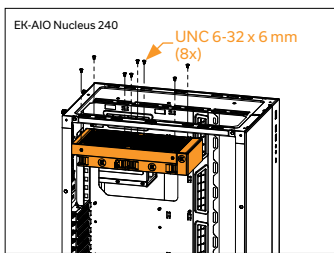

**STEP 8: INSTALLING THE ASSEMBLY OF FANS AND RADIATOR INTO A PC CASE**

Attach the assembly of radiator and the fan(s) to the PC case with the UNC 6-32 x 6 mm screws.

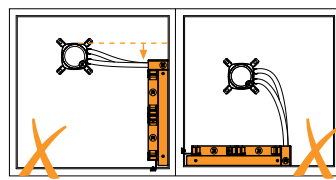

**Avoid vertical placement of the radiator with tubing on the top. (When the radiator reservoir is lower than the pump unit).**

**Avoid radiator at the bottom.**

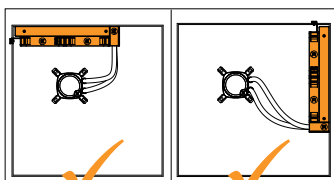

**Radiator on top (recommended).**

**Vertical placement of the radiator with tubing at the bottom (recommended).**

**Vertical placement of the radiator with tubing on the top. (The radiator reservoir must be placed higher than the pump unit.)**

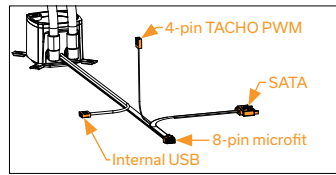
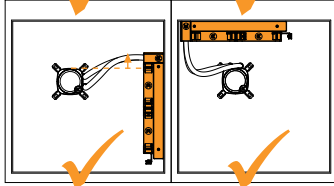

**STEP 9: PUMP – CONNECTING CABLES**

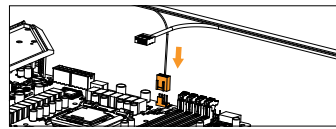

**STEP A:**  
Plug the 4-pin PWM connector from the pump to the motherboard.

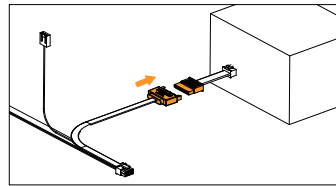

**STEP B:**  
Plug male SATA power connector to SATA female cable that was provided with your power supply unit.

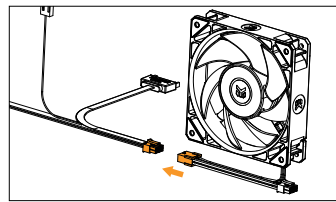

**STEP C:**  
Connect the female connector from the pump unit to the male connector from the first fan in line.

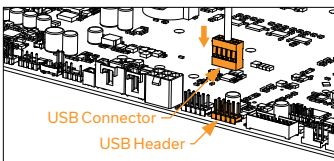

**STEP D:**

In the case of the EK-Nucleus Vision versions, plug the 4-pin USB connector from the pump to the USB HEADER on the motherboard.

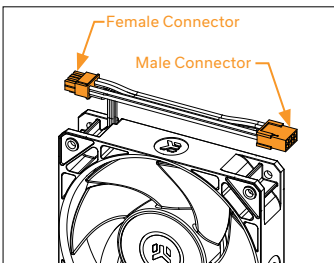

**STEP 10: FANS - CONNECTING CABLES**

If you followed previous steps you have already connected pump unit with the fans via 8-pin female to male connection.

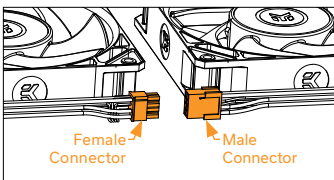

**STEP A:**

In the case of the EK-Nucleus AIO CR240 D-RGB or EK-Nucleus AIO CR360 D-RGB version, connect the second and third fan in series with the "daisy-chain".

Be careful to turn the connector correctly.

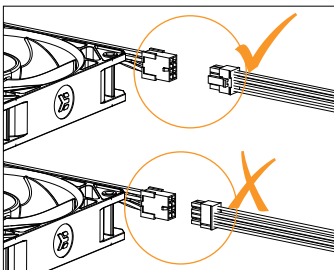

Be careful to turn the micro-fit connector correctly.

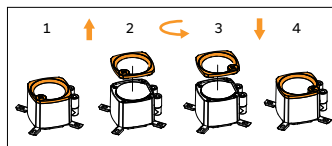

**STEP 11: PUMP TOP ORIENTATION**

Lift the top, rotate it until the EK logo is oriented correctly, and put it back down. The magnets will hold the top in place.

Congratulations! You have successfully installed your EK-Nucleus AIO.

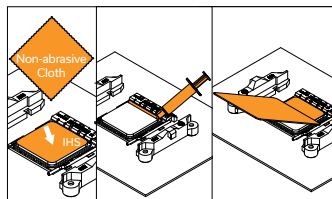

**OPTIONAL STEP 1! APPLYING THE THERMAL COMPOUND**

This step is relevant only in the case of a second installation of AIO or if you have damaged the pre-applied paste on the backside of the pump unit. For the first installation, you don't need to apply the additional thermal compound to the CPU's contact surface.

Wipe the CPU's contact surface (using a non-abrasive cloth or Q-tip, as shown in sample photo). On a clean IHS, apply a line of thermal compound and spread it over the whole CPU heat spreader (IHS) with a credit card or equivalent.

For help on how to control the D-RGB lights, please refer to your motherboard instructions.

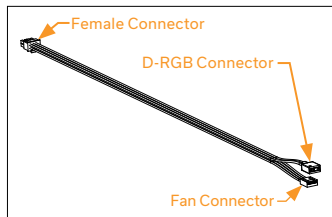

**OPTIONAL STEP 2! CHANGING FAN CONTROL**

If you don't want the pump unit to control your fans automatically, you can use the extension cable provided and connect the fans with motherboard as follows.

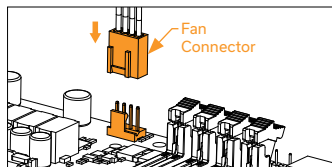

**STEP A:**

Connect the 4-pin fan connector from the extension cable directly to the CPU fan header on the motherboard. Always use CPU fan header when possible.



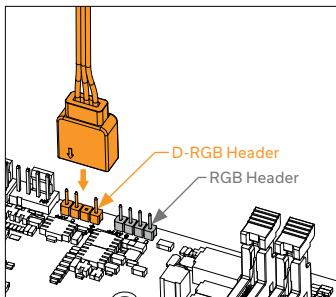

**STEP B:**

Plug the 3-pin D-RGB connector from the extension cable to the D-RGB header on the motherboard.



Please ensure that the arrow indicated on the connector is plugged into the +5V line as indicated on your motherboard. If you put LED Diode to the 12V RGB HEADER you can damage the LEDs.



Connector is the same on D-RGB and RGB versions, but D-RGB version has 3 cables from connector to PCB; RGB version has 4 cables. If you connect D-RGB led to ordinary RGB header you can damage your motherboard or LED strip.

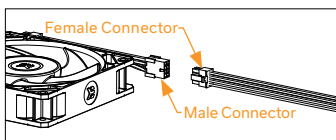

**STEP C:**

Connect the female connector from the extension cable to the male connector from the first fan in line.

If you have already connected 8-pin female connector from the pump unit (step 9 C) then disconnect it first.

**5. INSTALLATION – INTEL LGA 20XX SOCKET**

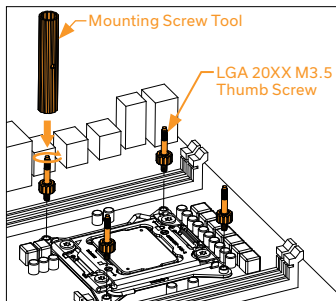

**STEP 1: ATTACHING MOUNTING SCREWS (LGA 20XX)**

**LGA 20xx (2066 / 2011 V3 / 2011) socket motherboards** do not require backplate installation. Install 4x LGA 20XX mounting thumb screws into M4 threaded stubs on the LGA 20XX socket integrated latch mechanism (ILM). The screws can be installed by using Mounting Screw Tool. Do not use other tools, because you may damage the motherboard. (i.e. pliers).



Continue installation by following the instructions from Step 4 on page 6

**6. INSTALLATION – AMD AM4/AM5 SOCKET**

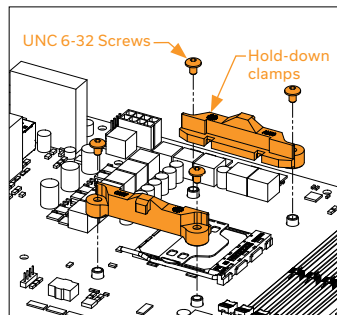

**STEP 1: REMOVING OF THE ORIGINAL PLASTIC HOLD-DOWN CLAMPS (AMD)**

Using a Philips head screwdriver, remove the four UNC 6-32 screws securing the original plastic hold-down clamps around the socket as shown on the sketch. **Keep the original AMD® backplate** and remove the hold-down clamps and store them away. See the image for further part identification.

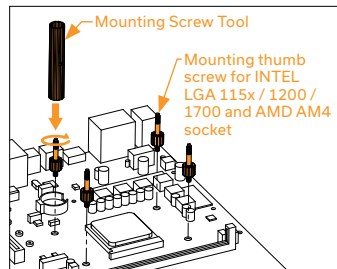

**STEP 2: ATTACHING MOUNTING SCREWS (AMD)**

Install 4x mounting thumb screw for AMD AM4 socket onto your motherboard. The screws can be installed by using Mounting Screw Tool. Do not use other tools, because you may damage the motherboard. (i.e. pliers).

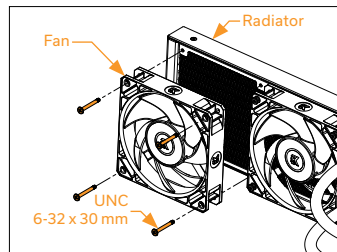

**STEP 3: INSTALLING THE FANS TO THE RADIATOR (AMD)**

Assemble the fans (2x - 3x - depending on the AIO version) to the radiator with the UNC 6-32 x 30mm screws.

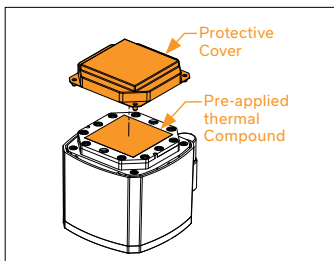

#### STEP 4: REMOVING THE COLD-PLATE PROTECTIVE COVER (AMD)

Remove the protective cover from the backside of the pump unit. It is there only to prevent damage to the cold-plate and the pre-applied thermal compound that is on the cold-plate.

When removing the protective cover and proceeding with installation be careful not to touch or damage the pre-applied thermal compound.

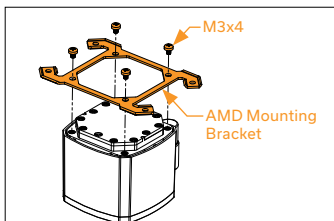

#### STEP 5: MOUNTING-BRACKETS INSTALLATION (AMD)

Use 4x M3x4 screws to install AMD bracket on the pump unit.

Be careful not to touch or damage the pre-applied thermal compound.



#### STEP 6: PUMP UNIT INSTALLATION (AMD)

Wipe the CPU's contact surface (using a non-abrasive cloth or a Q-tip as shown in the sample image).

Align the pump unit over the mounting screws and CPU as shown in the picture.

Place the enclosed compression springs and thumb nuts over the mounting screws (4x). Start fastening two thumb nuts at a time, preferably in a cross pattern, and do not tighten them fully until all of them are partially screwed in.

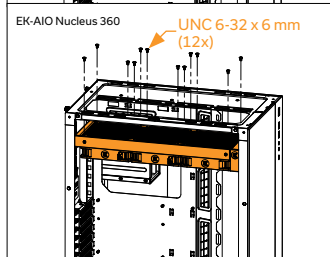
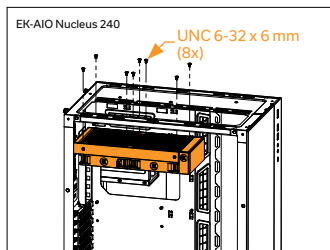
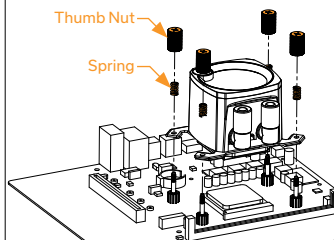

#### STEP 7: INSTALLING THE ASSEMBLY OF FANS AND RADIATOR INTO A PC CASE (AMD)

Attach the assembly of radiator and the fan(s) to the PC case with the UNC 6-32 x 6mm screws.

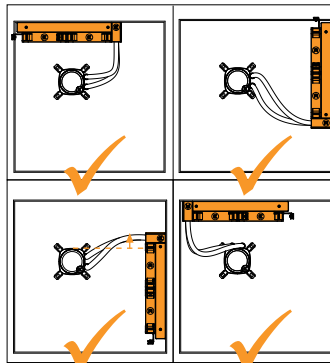

*Radiator on top (recommended).*

*Vertical placement of the radiator with tubing at the bottom (recommended).*

*Vertical placement of the radiator with tubing on the top. (The radiator reservoir must be placed higher than the pump unit.)*

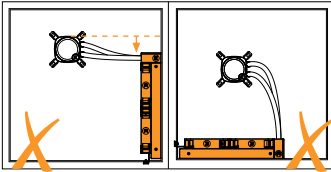

**Avoid vertical placement of the radiator with tubing on the top. (When the radiator reservoir is lower than the pump unit).**

**Avoid radiator at the bottom.**

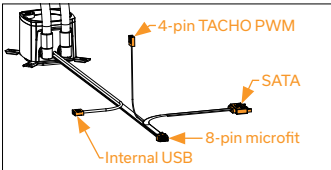

### STEP 8: PUMP – CONNECTING CABLES (AMD)

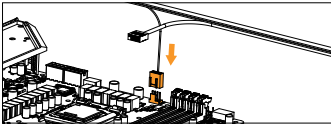

#### STEP A:

Plug the 4-pin PWM connector from the pump to the motherboard.

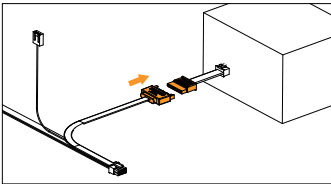

#### STEP B:

Plug male SATA power connector to SATA female cable that was provided with your power supply unit.

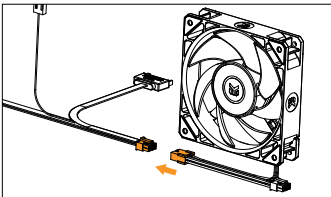

#### STEP C:

Connect the female connector from the pump unit to the male connector from the first fan in line.

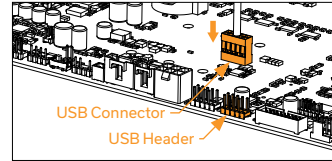

#### STEP D:

In the case of the EK-Nucleus Vision versions, plug the 4-pin USB connector from the pump to the USB HEADER on the motherboard.

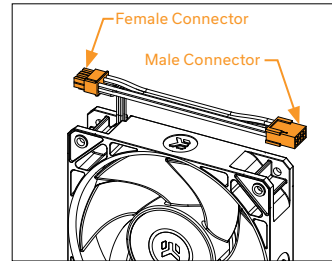

### STEP 9: FANS – CONNECTING CABLES (AMD)

If you followed previous steps you have already connected pump unit with the fans via 8-pin female to male connection.

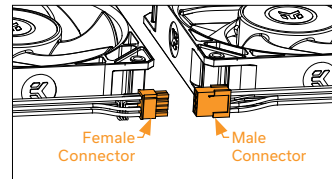

#### STEP A:

In the case of the EK-Nucleus AIO CR240 D-RGB or EK-Nucleus AIO CR360 D-RGB version, connect the second and third fan in series with the "daisy-chain".

Be careful to turn the connector correctly.

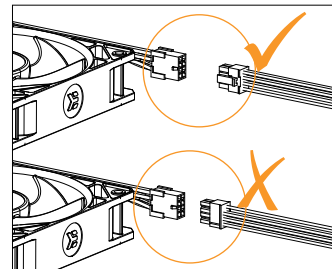

Be careful to turn the micro-fit connector correctly.

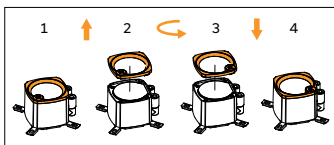

**STEP 10: PUMP TOP ORIENTATION (AMD)**  
Lift the top, rotate it until the EK logo is oriented correctly, and put it back down. The magnets will hold the top in place.

Congratulations! You have successfully installed your EK-Nucleus AIO.

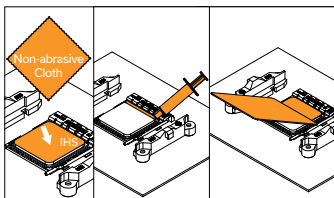

**OPTIONAL STEP 1! APPLYING THE THERMAL COMPOUND**

This step is relevant only in the case of a second installation of AIO or if you have damaged the pre-applied paste on the backside of the pump unit. For the first installation, you don't need to apply the additional thermal compound to the CPU's contact surface.

Wipe the CPU's contact surface (using a non-abrasive cloth or Q-tip, as shown in sample photo). On a clean IHS, apply a line of thermal compound and spread it over the whole CPU heat spreader (IHS) with a credit card or equivalent.

For help on how to control the D-RGB lights, please refer to your motherboard instructions.

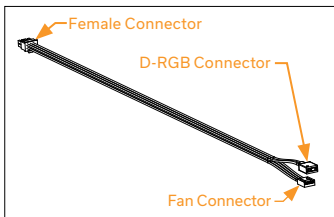

**OPTIONAL STEP 2! CHANGING FAN CONTROL**

If you don't want the pump unit to control your fans automatically, you can use the extension cable provided and connect the fans with motherboard as follows.

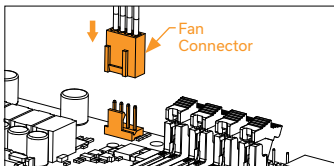

**STEP A:**  
Connect the 4-pin fan connector from the extension cable directly to the CPU fan header on the motherboard. Always use CPU fan header when possible.

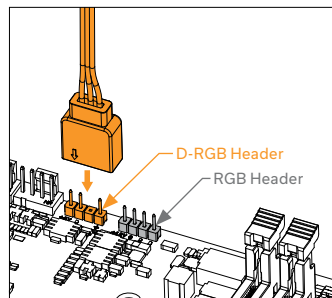

**STEP B:**  
Plug the 3-pin D-RGB connector from the extension cable to the D-RGB header on the motherboard.

**⚠** Please ensure that the arrow indicated on the connector is plugged into the +5V line as indicated on your motherboard. If you put LED Diode to the 12V RGB HEADER you can damage the LEDs.

**⚠** Connector is the same on D-RGB and RGB versions, but D-RGB version has 3 cables from connector to PCB; RGB version has 4 cables. If you connect D-RGB led to ordinary RGB header you can damage your motherboard or LED strip.

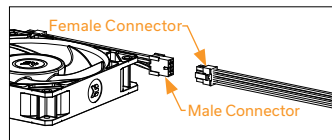

**STEP C:**  
Connect the female connector from the extension cable to the male connector from the first fan in line.

If you have already connected 8-pin female connector from the pump unit (step 9 C) then disconnect it first.

**7. DISPLAY SETUP & EK-CONNECT INSTRUCTIONS**

**GENERAL**

The EK-Nucleus AIO Vision offers extra features that can be configured through the EK-Connect application.

When the user runs the EK-Connect application, the software will check which EK devices are connected to the computer and adjust the user interface (UI) accordingly.

1. If the user has just the EK-Loop Connect controller connected, the interface will only show the menu items and screens pertaining to the EK-Loop Connect.
2. If the user has just the EK-Nucleus AIO Vision connected, the interface will only show the menu items and screens pertaining to the AIO device, in addition to a few screens with general computer stats.
3. If the user has both the EK-Nucleus AIO Vision and EK-Loop Connect controller connected, the interface will show all the available menu items and screens.

## THE EK-NUCLEUS AIO VISION DISPLAY SETUP

There are three setup screens in the EK-Connect application that let the user control the display.

### CPU

The user chooses their preferred temperature units, screen color mode, screen cycling, screen rotation, CPU temperature at which an alert is triggered, and performance indicators.

To the right of these settings, a color palette and picker are displayed, which let the user choose the design elements' color.

### GPU

The user chooses their preferred temperature units, screen color mode, screen cycling, screen rotation, GPU temperature at which an alert is triggered, and performance indicators.

To the right of these settings, a color palette and picker are displayed, which let the user choose the design elements' color.

### CPU + GPU

This screen combines the CPU and GPU setup screens and lets the user set parameters for both components.

## 8. GENERAL SAFETY WARNINGS

### First aid measures in case of:

**Skin exposure to coolant:** Remove contaminated clothing and rinse thoroughly with plenty of running water or normal saline rinse. If symptoms develop and persist, seek professional medical attention.

**Eye exposure to coolant:** Immediately open upper and lower eyelids, flush out with running water or normal saline rinse. If irritation persists, seek professional medical attention.

**Inhalation of coolant:** Remove yourself from site to fresh air. If symptoms develop and persist, seek professional medical attention.

**Ingestion of coolant:** Drink plenty of warm water and do not induce vomiting. In case of doubt or if feeling unwell, seek professional medical attention.

**Skin exposure to thermal paste:** Wash thoroughly with soap and water for a minimum of 15 minutes. Contaminated clothing should be removed immediately. If irritation persists, obtain medical attention.

**Eye exposure to thermal paste:** Flush out thoroughly with running water for a minimum of 15 minutes. If irritation persists, seek professional medical attention.

**Inhalation of thermal paste:** If adverse effects occur, proceed to an uncontaminated area. If breathing has been arrested, provide artificial respiration immediately. Seek immediate medical attention.

**Ingestion of thermal paste:** Drink 2 large glasses of water. Do not induce vomiting. If a large amount has been ingested, or if discomfort persists, obtain professional medical attention.

## 9. SUPPORT AND SERVICE

For assistance please contact: <http://support.ekwb.com/>

EKWB d.o.o.  
Pod lipami 18  
1218 Komenda  
Slovenia – EU

## 10. SOCIAL MEDIA

