

EK-Loop Leak Tester Flex

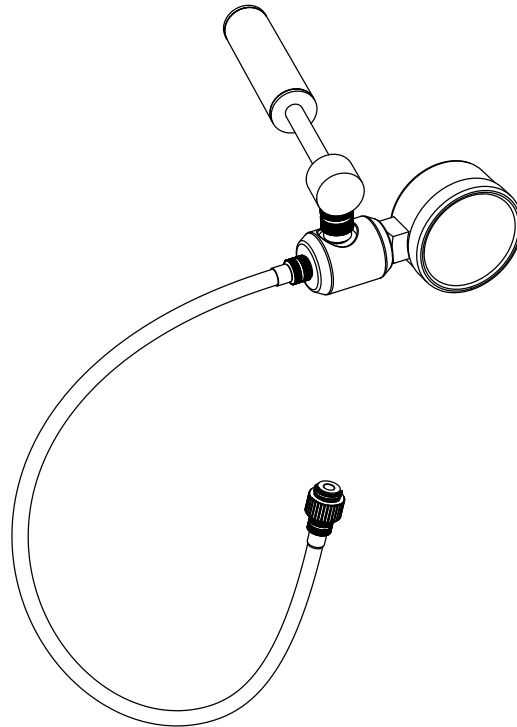

This product is intended for installation only by expert users. Please consult with a qualified technician for installation. Improper installation may result in damage to your equipment. EK Water Blocks assumes no liability whatsoever, expressed or implied, for the use of these products, nor their installation. The following instructions are subject to change without notice. Please visit our website at www.ekwb.com for updates.

Before you start using this product, please follow these basic guidelines:

The Leak Tester's Tube Fitting requires only a small amount of force to screw it firmly in the G1/4 threaded port of the tested component, since the air seal is ensured by the rubber O-ring gasket.

Use a Leak Tester only when all the components are tightly sealed together and before filling the loop with the coolant.

TABLE OF CONTENTS

GENERAL INFORMATION	4
HOW TO USE THE LEAK TESTER	5
WHAT TO DO IN CASE YOU NOTICE A PRESSURE DROP	7
SUPPORT AND SERVICE	8
SOCIAL MEDIA	8

GENERAL INFORMATION

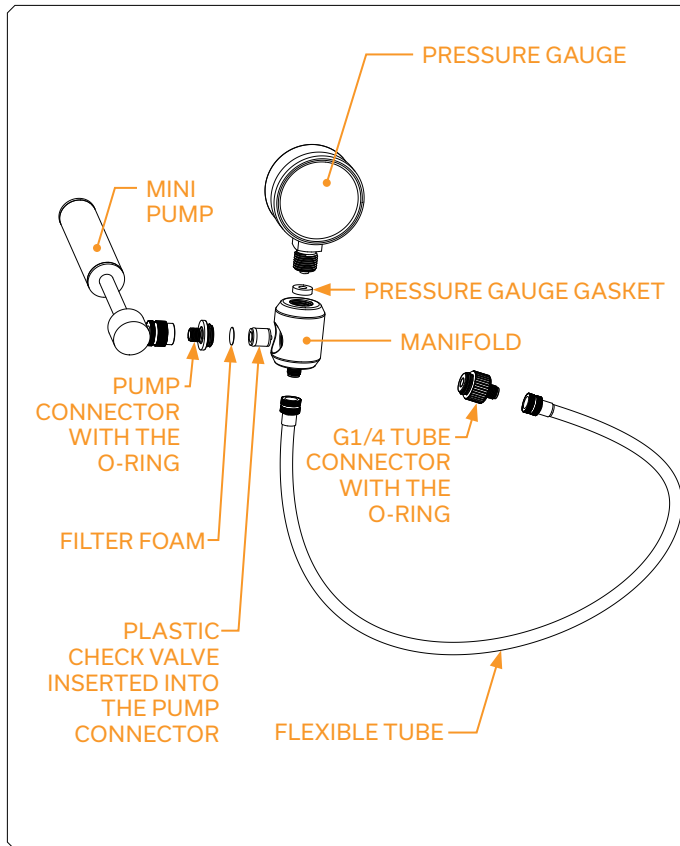

The EK-Loop Leak Tester Flex is a fast and safe way of testing for possible leaks in your liquid cooling loop. One end is fitted with a revolvable male G1/4" connection port so it can be directly screwed into any standard port in your liquid cooling loop. The other end is hooked up with a non-return valve which will make sure that no air is escaping through the tester unit itself. A small pump for pressurizing the loop is also included. Please keep the pressure only in the pre-defined zone marked on the gauge to prevent damage to your liquid cooling hardware OR see the table below for use in specific cases.

The leak tester is designed to assure users that the newly made loop is watertight and ready for filling and use. With the Leak Tester, it is not necessary to complete a 24h test, which should otherwise be performed. This tool also can 're-certify' blocks that have been opened for cleaning and reassembled.

HOW TO USE THE LEAK TESTER

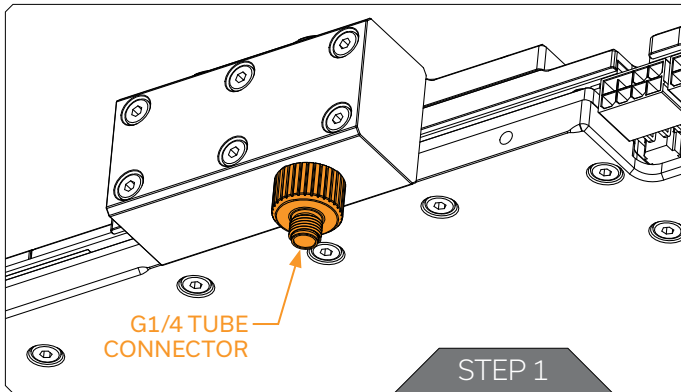

STEP 1

Check that the tested system (Loop / Water Block / Distribution Plate / Reservoir / ...) is sealed everywhere except for one free G1/4 port. Screw the Tube Connector to this G1/4 port.

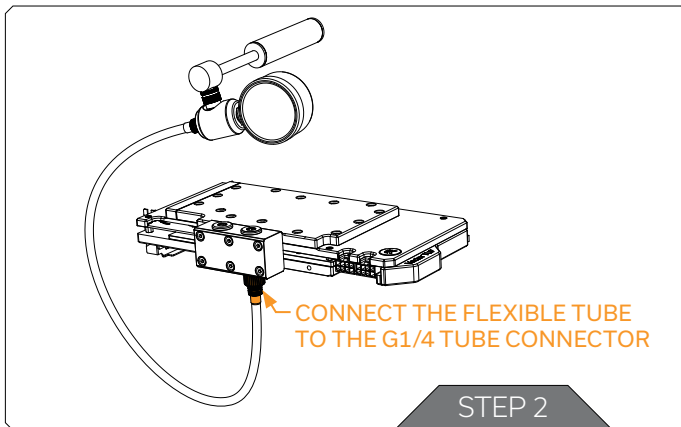

STEP 2

Assemble the rest of the Leak Tester from the box and attach the Leak Tester's Flexible Tube to the G1/4 Tube Connector.

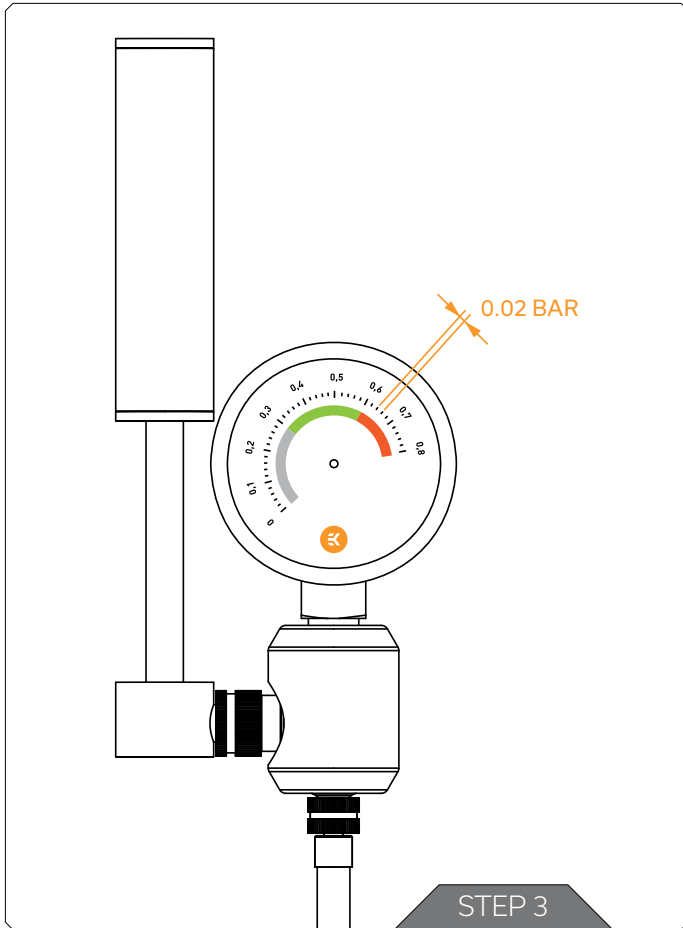

STEP 3

Pump the air via a Mini Pump to set the pressure using the Pressure Gauge on the unit. See the table below for the exact charging pressures.

PRODUCT	CHARGING PRESSURE (BAR)
Loop	0.45 +/- 0.15
Waterblock	0.6 +/- 0.05
Reservoir	0.6 +/- 0.05
Radiator	0.6 +/- 0.05
Distribution plate / Manifold	0.45 +/- 0.15
EK-Classic DP Front PC-O11D - Distribution plate	0.3 +/- 0.05

When you pressurize the loop with air, wait a few moments for the pressure to stabilize. Read and memorize the pressure mark on the Pressure Gauge and wait for five (5) to a maximum of fifteen (15) minutes to check for a drop in the Pressure Gauge's needle. If there is no pressure drop (leak), your liquid cooling loop is watertight. Also, keep in mind that air leaks more easily than coolant.



When testing systems with a smaller volume, the pressure on the manometer can fluctuate by + -0.02 bar (for example, if the temperature changes), which does not mean that the system is leaking.

WHAT TO DO IN CASE YOU NOTICE A PRESSURE DROP

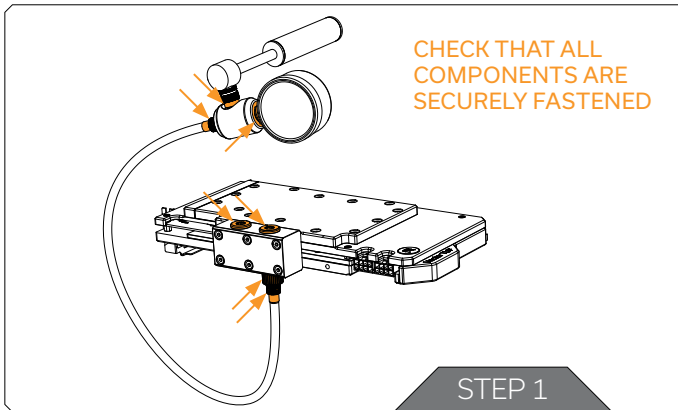

STEP 1

If the leak tester shows that the tested system or component is leaking, first check that all fittings in the loop are firmly attached. Verify that the components on the Leak Tester itself are not loosened. Check that Flexible Tube's Fittings on both sides, Pressure Gauge, G1/4 Tube Connector with the O-ring and Pump Connector are tightly attached.

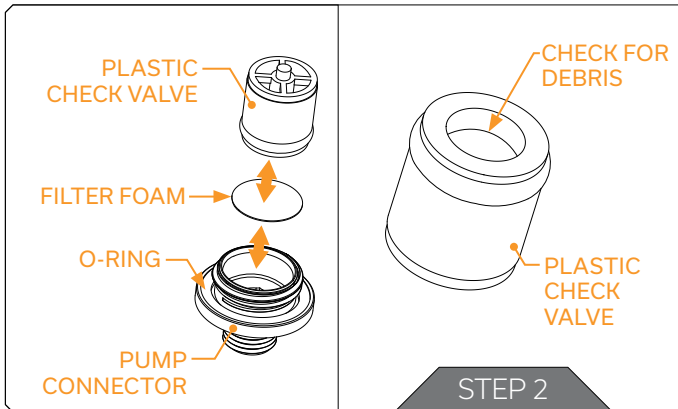

STEP 2

In rare cases, debris can accumulate in the »Plastic Check Valve« which causes it to lose pressure. You can check this by unscrewing the "Pump connector" with an Allen key (size 4 mm) and removing the Check Valve together with the Filter Foam. Gently push both of them out of the Pump Connector using the same Allen key.

If you notice any debris in the Check Valve, remove or blow them away and reassemble the Leak Tester. Remember to install the Filter Foam back into the Pump Connector as well.

SUPPORT AND SERVICE

In case you need assistance or wish to order spare parts or a new mounting mechanism, please contact:

<https://www.ekwb.com/customer-support/>

EKWB d.o.o.
Pod lipami 18
1218 Komenda
Slovenia – EU

SOCIAL MEDIA

 EKWaterBlocks

 @EKWaterBlocks

 ekwaterblocks

 EKWBofficial

 ekwaterblocks

