

This product is intended for installation only by expert users. Please consult with a qualified technician for installation. Improper installation may result in damage to your equipment. EK Water Blocks assumes no liability whatsoever, expressed or implied, for the use of these products, nor their installation. The following instructions are subject to change without notice. Please visit our web site at [www.ekwb.com](http://www.ekwb.com) for updates. Before installation of this product please read important notice, disclosure and warranty conditions printed on the back of the box.

Before you start using this product please follow these basic guidelines:

1. Please carefully read the manual before through before beginning with the installation process!
2. The EK High Flow and EK-PSC type fittings require only a small amount of force to screw them firmly in place since the liquid seal is ensured by the rubber o-ring gaskets.
3. The use of corrosion inhibiting coolants is always recommended for any liquid cooling system.

## STEP 1: PREPARING THE PUMP

Unscrew the four screws that attaches the Laing pump's original factory top and the main pump core housing with motor. Store these four screws as well as factory pump top in a safe place.

**Remember to keep the original o-ring gasket!**

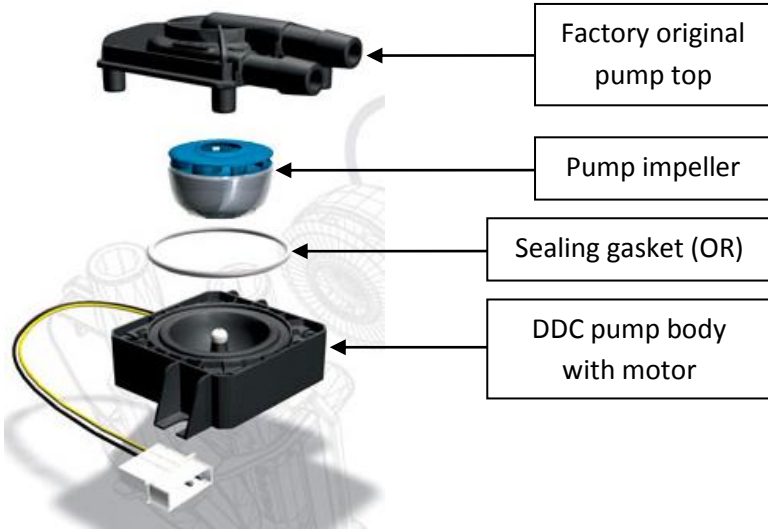

## STEP 2: INSTALLING THE XRES

1. Install the EK-XRES DDC on to the pump main motor housing. **Make sure you re-use the original o-ring gasket!** Reseat the gasket if needed. You can rotate the XRES DDC in and use it in any direction (90° step turns).
2. Secure the XRES DDC using enclosed M4x25 ISO7985 screws using enclosed 2.5mm Allen key. Do not over tighten the screws as excessive force may strip the threading.

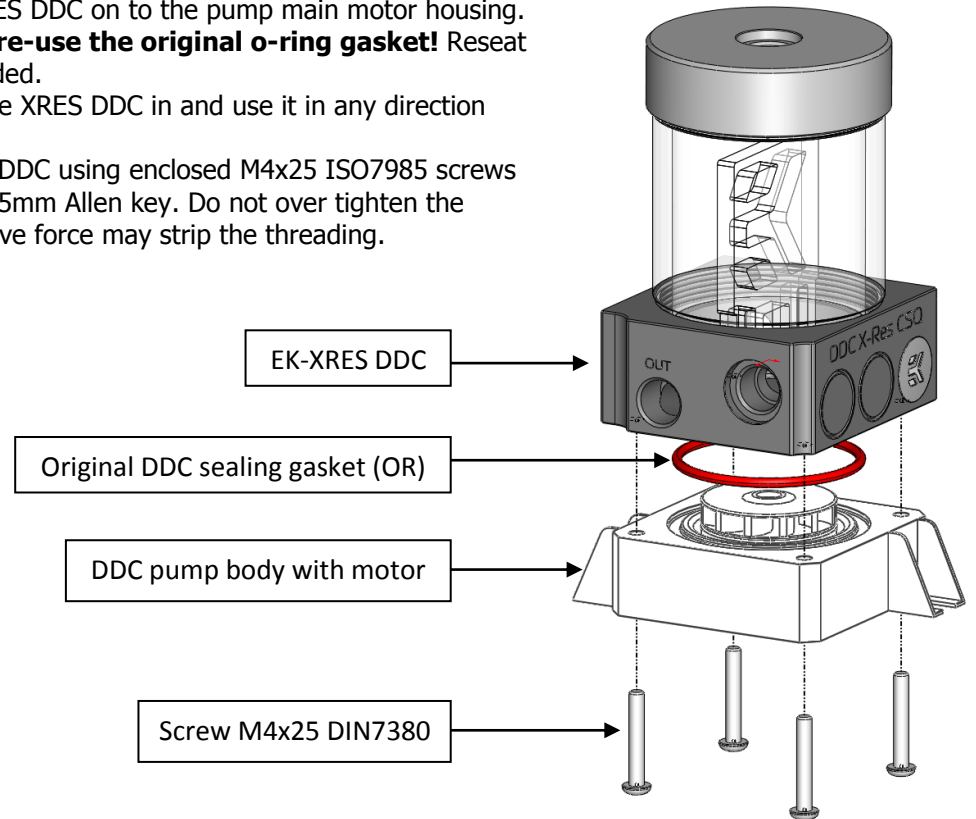

## STEP 3 (optional): USING POLYETHER ANTI-VORTEX FOAM:

EK-XRES DDC series pump top / reservoir comes preinstalled with Anticyclone by default. In case your system suffers from excessive vortex issues, air bleeding problems or if the pump is sucking in air you may replace the anticyclone with the enclosed polyether foam. There are two ways to use the polyether anti-vortex foam:

### Default configuration



This is the default configuration of EK-XRES DDC series reservoir.

### PE foam – use whole



Use the foam as a whole to replace the Anticyclone.

### PE foam – trim to fit recess

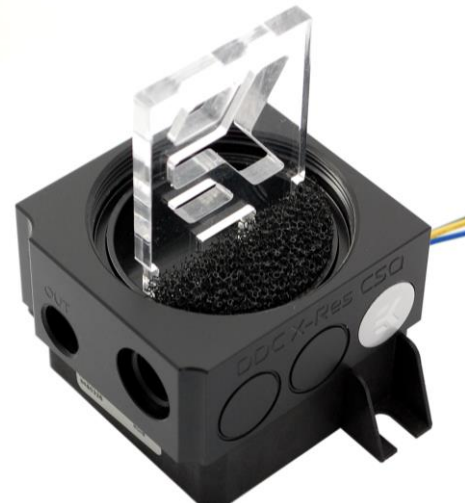

Trim the foam to size to fit into the desired inlet recess on the XRES main body.

## STEP 4: ATTACHING FITTINGS

EK-XRES DDC series reservoir pump combo featured 3 (three) G1/4 threaded opening on the main body of which 2 (two) are inlets and one is outlet (clearly marked with 'OUT'). EKWB recommends using EK-PSC fittings with the EK-XRES DDC series reservoir pump combo units. To ensure that the tubes are securely attached to the barb/fittings, please use hose clamps or an appropriate substitute.

**It is mandatory to use the correct INLET and OUTLET ports:**

1. The OUTLET port (pressure port) is clearly marked with label 'OUT' engraved on the pump top housing.
2. The INLET port(s) (suction port) are the two recessed ports with G1/4 threading on the EK-XRES DDC front face plane. You may use any of these two ports as an INLET port. It is necessary to use the enclosed EK-Extender G1/4 underneath the INLET fitting! Please refer to the picture on the right! **Do not forget to close off the unused INLET port** using EK-Plug G1/4!
3. Make sure not to use fittings or barbs with G1/4 thread longer than 5mm! All EK-PSC and High Flow fittings are compatible!

This water pump & EK-XRES DDC combo can be used in vertical mounting configuration (position) only! Mounting the pump upside down may result in pump running dry and eventually lead to premature failure of the pump!

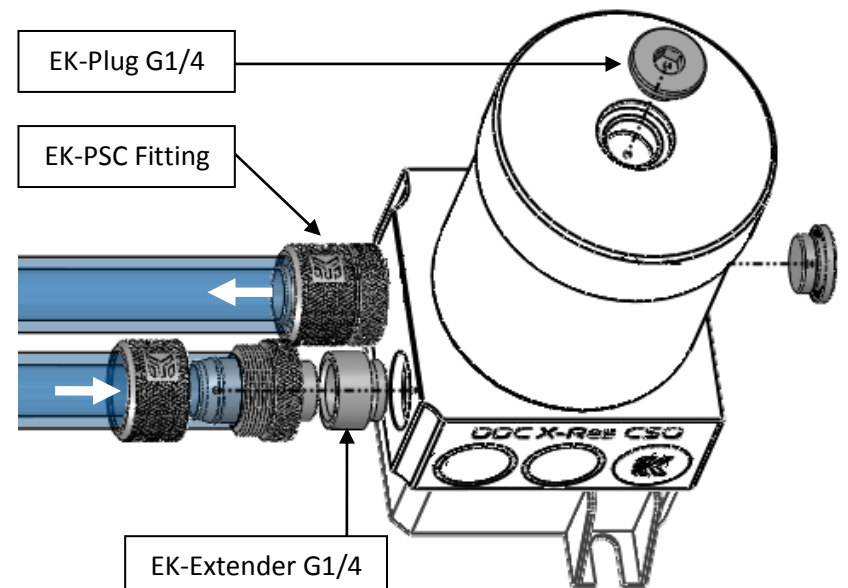
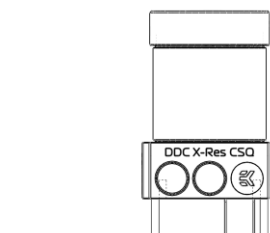

REQUIRED TOOLS: -