

EK-Quantum Vector FTW3 RTX 3070 Backplate

BACKPLATE

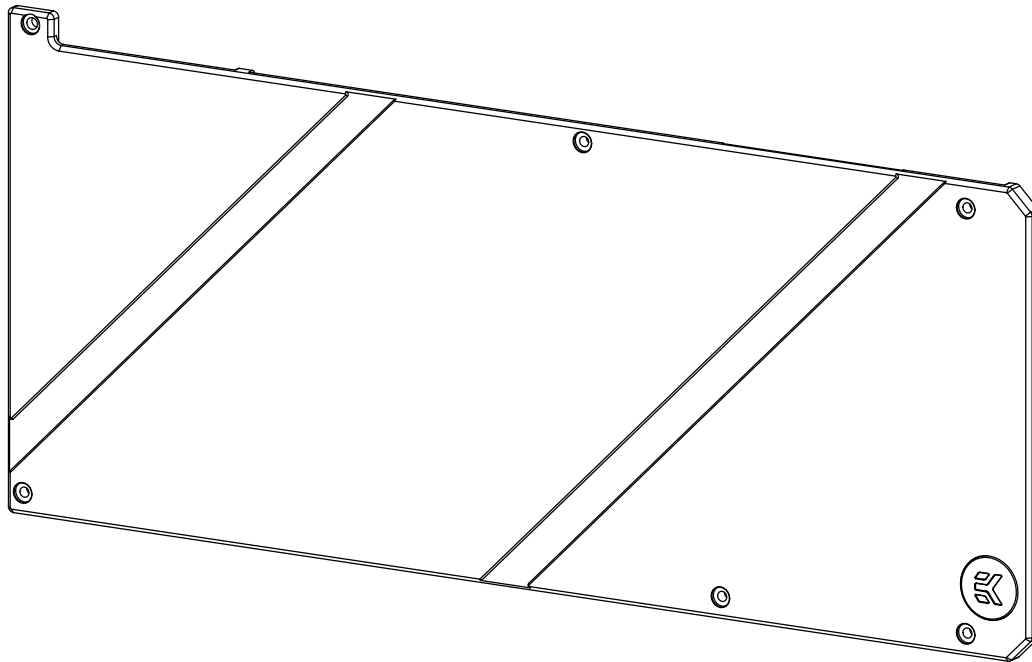

This product is intended for installation only by expert users. Please consult with a qualified technician for installation. Improper installation may result in damage to your equipment. EK Water Blocks assumes no liability whatsoever, expressed or implied, for the use of these products, nor their installation. The following instructions are subject to change without notice. Please visit our web site at www.ekwb.com for updates.

Before you start using this product, please follow these basic guidelines:

Please carefully read the manual thoroughly before beginning with the installation process!

Please remove your graphics card from the computer to assure safest mounting process in order to prevent any possible damages to your GPU and/or graphics card circuit board (PCB).

TABLE OF CONTENTS

BOX CONTENTS	4
BACKPLATE DIMENSIONS	5
REQUIRED TOOLS	5
INSTALLING THE BACKPLATE	6
PREPARING THE GRAPHICS CARD	6
CUTTING AND PLACING THERMAL PADS	6
ATTACHING THE BACKPLATE	7
TESTING THE LOOP	8
WARRANTY	8
SUPPORT AND SERVICE	9
SOCIAL MEDIA	9

BOX CONTENTS

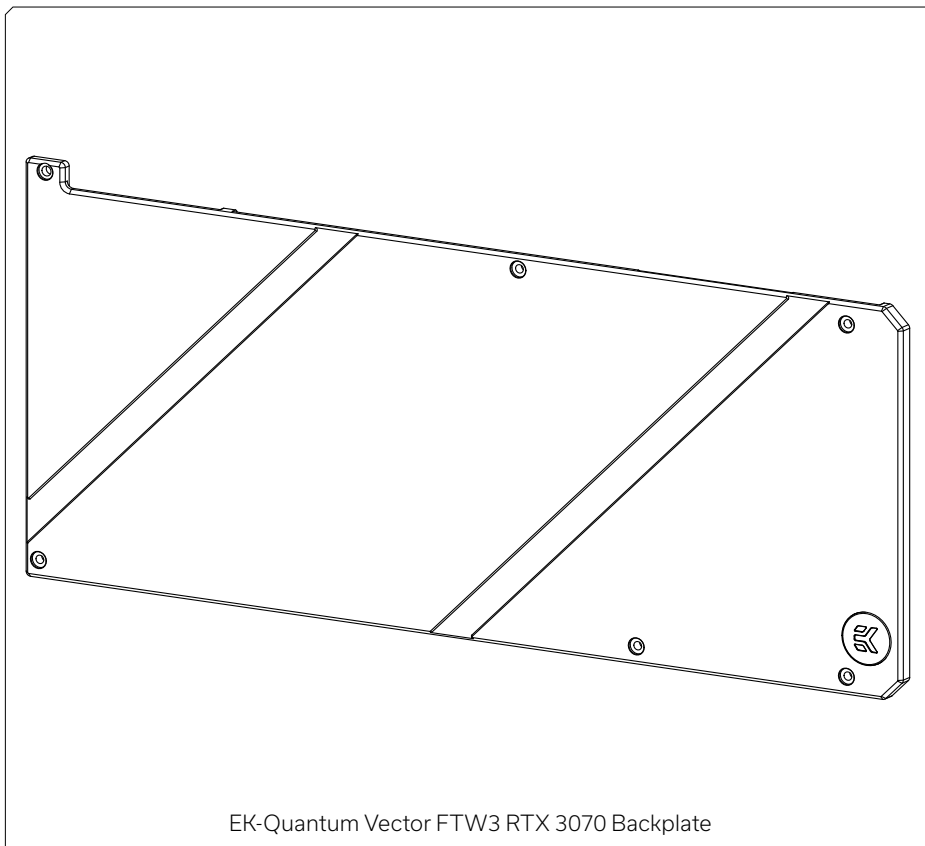

Mounting mechanism - You may not need all the screws, mounting mechanism is universal!

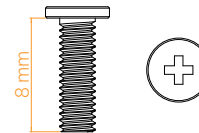

M2.5x8 AX1 Screw (8 pcs) Black

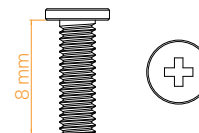

M2.5x8 AX1 Screw (8 pcs) Nickel

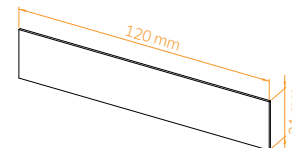

Thermal PAD G 1.5 mm - (120x24mm) (2 pcs)

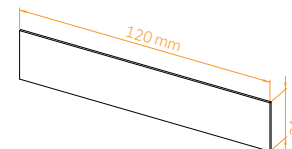

Thermal PAD G 2.0 mm - (120x24mm) (1 pcs)

BACKPLATE DIMENSIONS

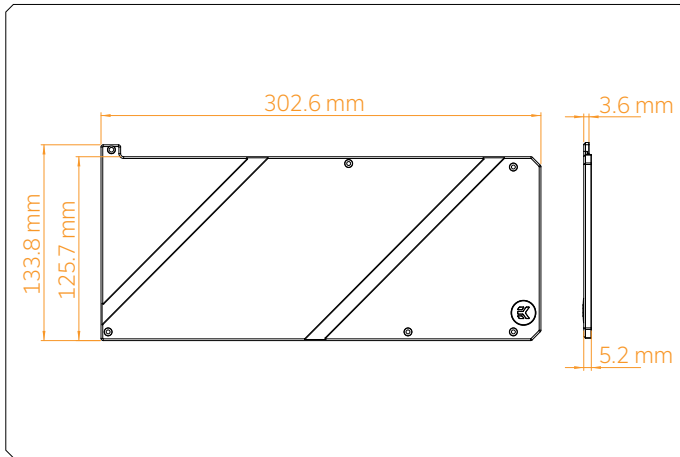

REQUIRED TOOLS

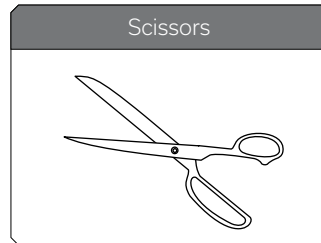
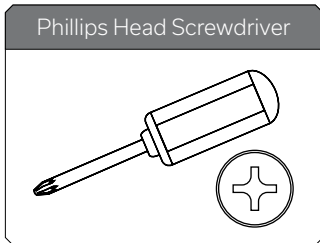

INSTALLING THE BACKPLATE

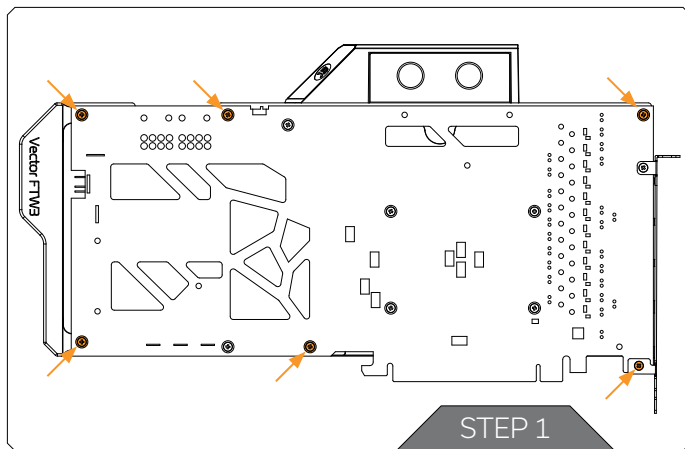

STEP 1

PREPARING THE GRAPHICS CARD

First complete the installation of your **EK-Quantum Vector FTW3 RTX 3070** water block according to its installation manual.

If water block is already installed, remove the six (6) AX1 screws and their PVC washers (marked on the picture).



STEP 2

CUTTING AND PLACING THERMAL PADS

Your backplate is supplied with thermal pads that needs to be cut into smaller pieces in order to cover all VRM components. EK made sure to provide customers with more than adequate quantity of thermal pads to complete this step.



PLEASE REMOVE THE PROTECTIVE FOIL FROM BOTH SIDES OF THE THERMAL PADS PRIOR TO INSTALLATION!

Replacement thermal pads:

2x Thermal PAD G 1.5 mm - (120 x 24 mm) - EAN: 3830046996787

1x Thermal PAD G 2.0 mm - (120 x 24 mm) - EAN: 3830046996794

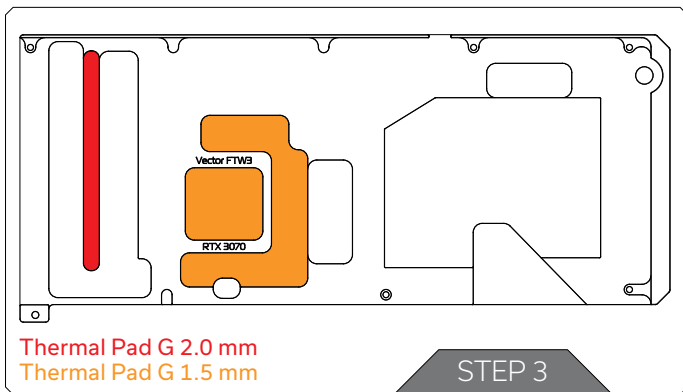

STEP 3

Once cut to size thermal pads should be applied to the backplate as shown in the image.

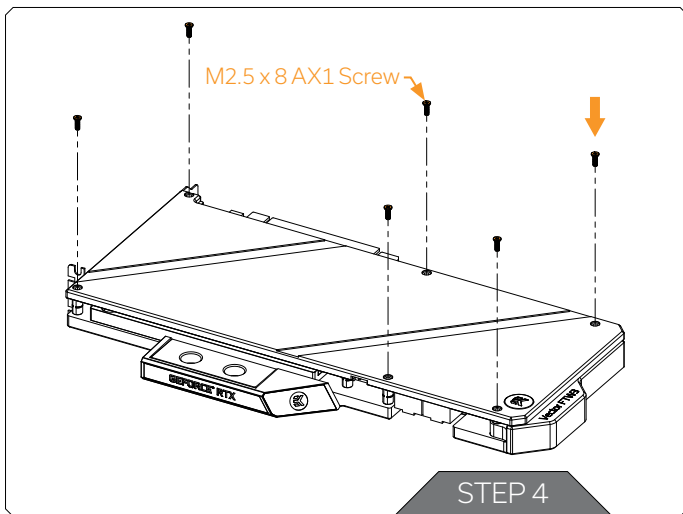

STEP 4

ATTACHING THE BACKPLATE

Place the backplate on to the PCB aligning all of the holes. Position an M2.5 x 8 AX1 screw in each of the six (6) mounting holes marked below and then tighten them evenly using a Phillips head screwdriver.

Do not use excessive force!

For this Step, you will need:

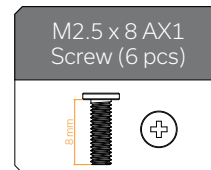
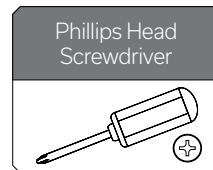

TESTING THE LOOP

To ensure the installation of EK components was successful, we recommend you perform a 24-hour leak test.

When your loop is complete and filled with coolant, connect the pump to a PSU outside your system. Do not connect power to any of the other components. Turn on the PSU and let the pump run continuously. Inspect all parts of the loop, and in case the coolant leaks, fix the issue and repeat the testing process.

To prevent possible damage, please ensure that all hardware is dry before the system is powered on.

WARRANTY

Our products are warranted against defects of materials and quality for a period of 24 months, starting with the date of delivery to the end-user. During this period, products will be repaired or have parts replaced at our discretion, provided that 1) the product is returned to the agent from whom it was purchased; 2) the product has been purchased by the end-user and has not been used for commercial purposes; 3) the product has not been misused, handled carelessly, or used in a manner other than the way described in the instructions manual. This warranty does not confer rights other than those expressly set out above and does not cover any claims for consequential loss or damage. This warranty is offered as an extra benefit and does not affect your statutory rights as a consumer. This warranty is voided if the product comes in contact with aggressive UV additives or other improper liquids. EK water blocks are sealed with a warranty-voiding circular label, proving the water block has withstood a pressure leak test. Removing the label will void the leak-free guarantee, but not the guarantee on the product itself. Any other RMA issues can be reported to EK Customer Support at www.ekwb.com/support for further analysis.

SUPPORT AND SERVICE

In case you need assistance, please contact:
<https://www.ekwb.com/customer-support/>

EKWB d.o.o.
Pod lipami 18
1218 Komenda
Slovenia - EU

SOCIAL MEDIA

 EKWaterBlocks

 @EKWaterBlocks

 ekwaterblocks

 EKWBofficial

 ekwaterblocks

