

This product is intended for installation only by expert users. Please consult with a qualified technician for installation. Improper installation may result in damage to your equipment. EK Water Blocks assumes no liability whatsoever, expressed or implied, for the use of these products, nor their installation. The following instructions are subject to change without notice. Please visit our web site at [www.ekwaterblocks.com](http://www.ekwaterblocks.com) for updates. Before installation of this product please read important notice, disclosure and warranty conditions printed on the back of the box.

**The barb hose fittings require only a small amount of force to screw them in; otherwise the high flow fittings might break. These fittings do not need to be tightened with much force because the liquid seal is made using o-rings.**

## STEP 1: GENERAL INFORMATION. Sample picture of NVidia GeForce 460 GTX PCB design



## STEP 2: PREPARING YOUR GRAPHIC CARD

**1. REMOVING STOCK COOLER.** Remove all encircled screws. All heat sink assembly screws and retention plate should be removed. There are 4 screws on the back of the graphic card.

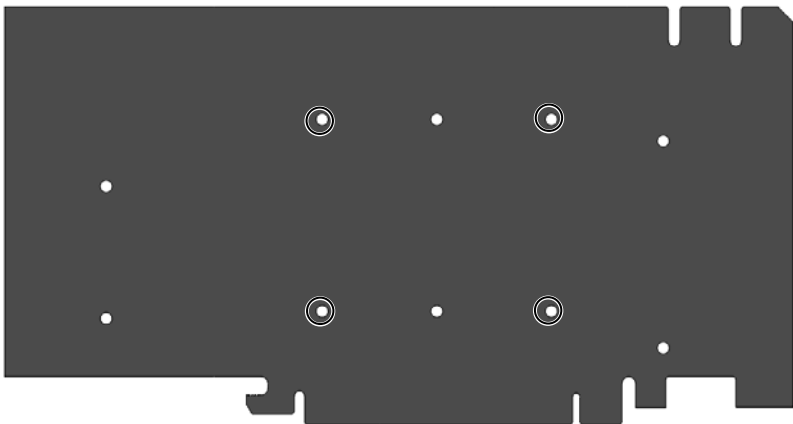

**2. CLEANING THE PCB.** Carefully detach the original heat sink after removing all fasteners securing it to the board and bracket. Wipe off the remains (by using non-abrasive cloth or Q-tip, as shown on sample photo) of the original thermal compound until the components and circuit board are completely clean. EKWB does not recommend using any liquids for removing paste.



### 3. APPLYING THERMAL COMPOUND

Apply thermal compound: lightly coat the GPU with for example Arctic Cooling MX2™ or MX3™ thermal compound. Follow this link: [http://www.arctic-cooling.com/catalog/images/install\\_mx2\\_retail.pdf](http://www.arctic-cooling.com/catalog/images/install_mx2_retail.pdf) for detailed instructions. EKWB recommends to apply thermal grease in cross form for best performance (see sample picture).

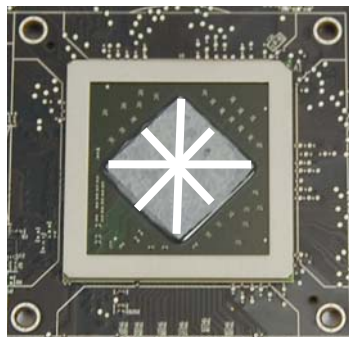

**4. CUTTING THERMAL PADS.** Your block comes with thermal pads, which have to be placed on chips (PLEASE REMOVE FOIL ON BOTH SIDES OF THERMAL PADS PRIOR TO INSTALLATION. WARNING: DIMENSION BELLOW ARE SCALED.) All thermal pads are **1mm** thick.

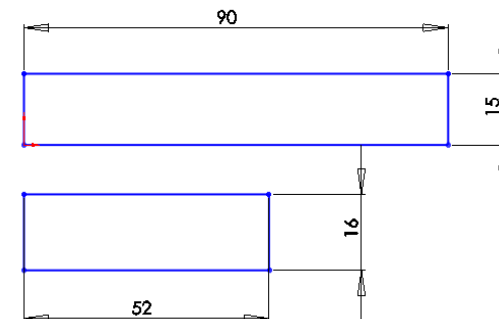

## STEP 3: INSTALLING WATER BLOCK

**1. PLACING THERMAL PADS ON PCB.** Place thermal pads on chips so that numbers on chips match size of thermal pads. Thermal pads have to be cut by user to match all small chips (EKWB made sure users have more than enough pads to cover all surfaces that need to be covered to make block fully function). You can also use small drop of thermal grease on chips to make thermal pads more adhesive.

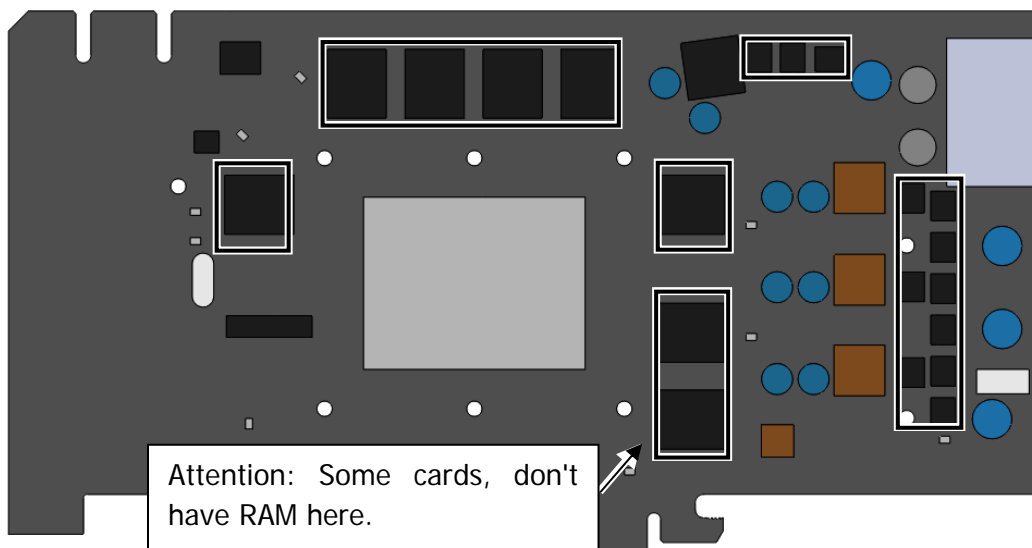

**2. PLACING STANDOFFS ON BLOCK.** Please use small amount of thermal grease on standoffs and glue them so they are concentric with mounting holes. Once they are stuck to block be careful not to move them.

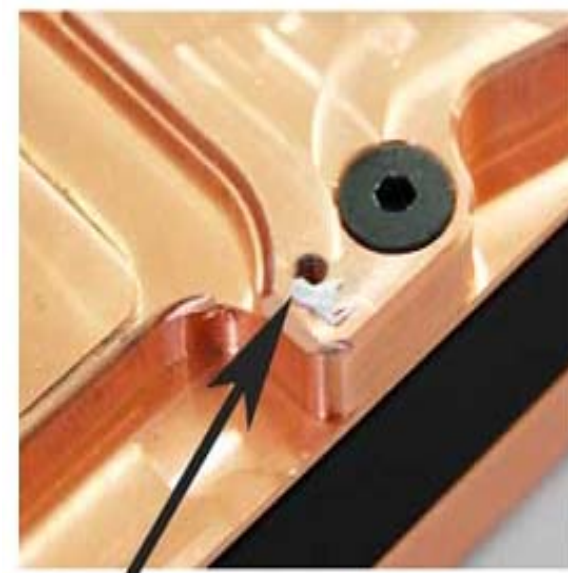

2.cont.. PLACING STANDOFFS ON BLOCK. Standoffs (thickness 3,9mm) are obligatory to make this block fully functional and safe mounting.

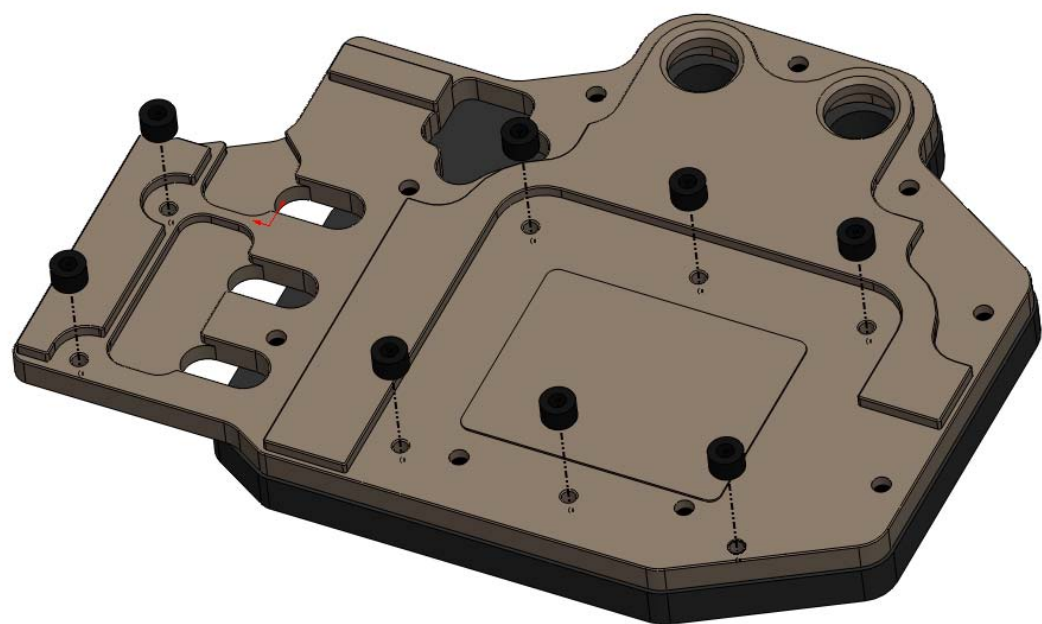

3. ATTACHING BLOCK TO GRAPHIC CARD. By using Philips screwdriver, screw in enclosed M3x8 screws. EKWB recommends start screwing the screws around the GPU core and continue outwards. (HINT: leave screws half screwed in until all are in their place, then fasten them. However, do not overdo it, as you may strip threads.)

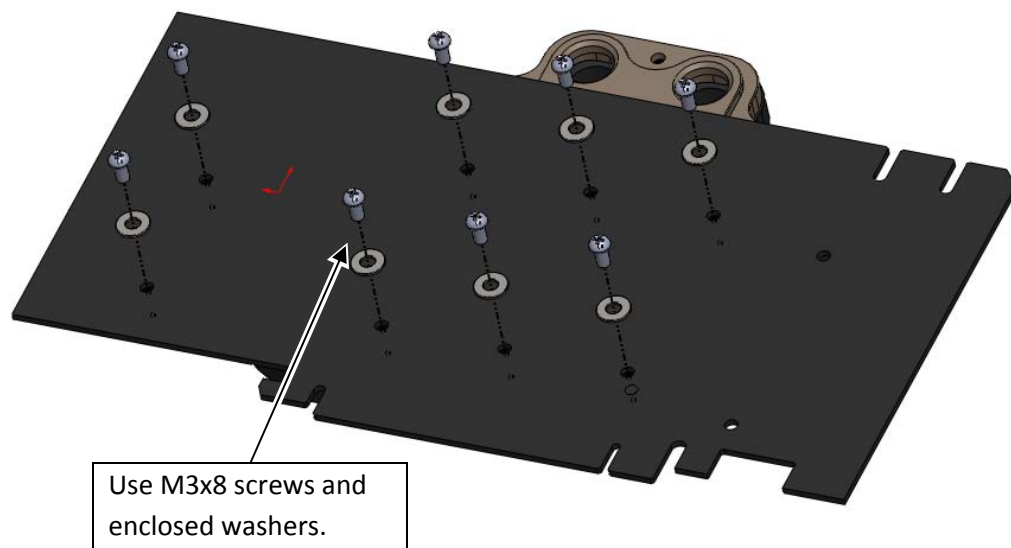

#### STEP 4: CHECKING FOR CONTACTS

Temporarily remove the water block to check for uniform surface contact between the block and the components. Note the pattern of contact on a piece of paper. Then repeat substeps in previous section to reattach the block. In case you can't get good contact, please check again your thermal pad thickness or contact our support service.

#### STEP 5: POSITIONING FITTINGS

Please use spacer only on copper base if you use fitting with G1/4 thread longer than 5mm (see sample picture). Screw in the fittings and plugs (please use spacers only on copper base for fittings). Use 6mm Allen key to screw in and tighten new EK-Plug G1/4. Attach the liquid cooling tubes and connect the water-block(s) into the cooling circuit. EKWB recommends using high flow fittings with the EK-FC 4X0 GTX series water blocks. To ensure that the tubes are securely attached to the barb/fittings, please use hose clamps or an appropriate substitute. The use of an algaecide is always recommended for any liquid cooling system. You can use any hole as an inlet/outlet hole.

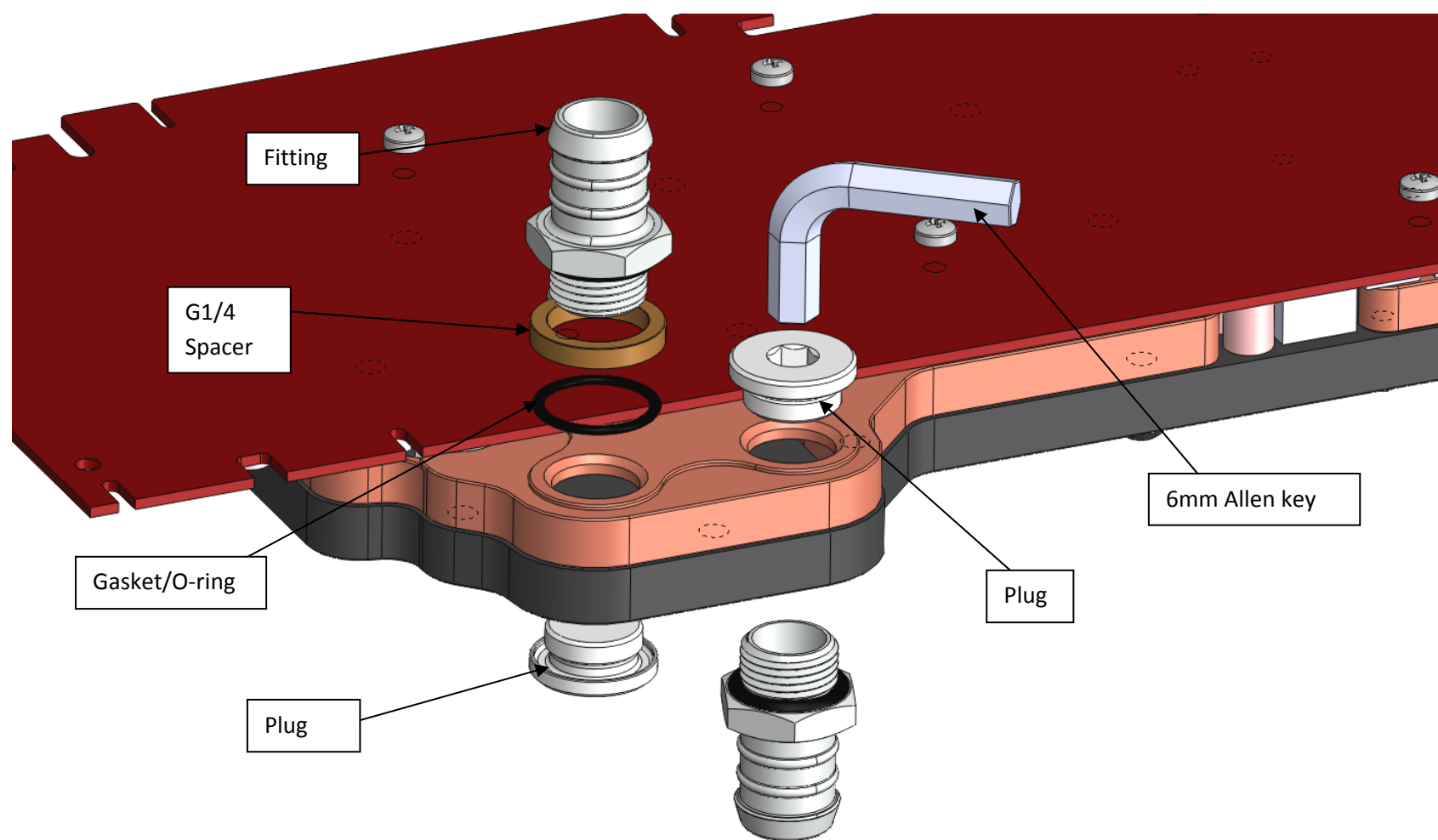

#### STEP 6: INSERTING CARD IN YOUR PC CASE

Carefully lift your card with installed block and insert it in your PC case. Please bear in mind that your card suddenly withstands extra weight thus again be very careful not to bend it or cause any other unneeded moves that might damage your card or block during installation.

#### REQUIRED TOOLS AND MOUNTING SCREWS:



scissors



philips screwdriver



8 x screws M3x8 DIN7985