

EK-Quantum Velocity RGB/D-RGB Mounting Plate



This product is intended for installation by expert users only. Please consult with a qualified technician. Improper installation may result in damage to your equipment. EK Water Blocks assumes no liability whatsoever, expressed or implied, for the use of these products or their installation. The following instructions are subject to change without notice. Please, read the manual carefully before beginning with the installation process.

TABLE OF CONTENT

| | |
|--|---|
| REPLACING THE MOUNTING PLATE AND RGB/D-RGB LED | 4 |
| CONNECTING THE RGB LED STRIP | 6 |
| CONNECTING THE D-RGB LED STRIP | 7 |
| SUPPORT AND SERVICE | 8 |
| SOCIAL MEDIA | 8 |

REPLACING THE MOUNTING PLATE AND RGB/D-RGB LED

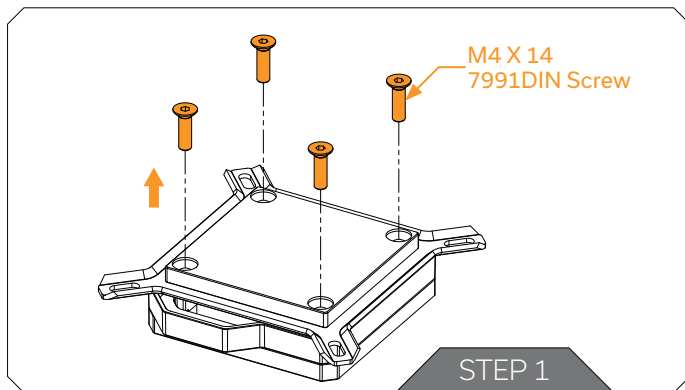

STEP 1

Unscrew the four (4) screws from the backside of the CPU water block using the Phillips head screwdriver. Store the screws for later use.

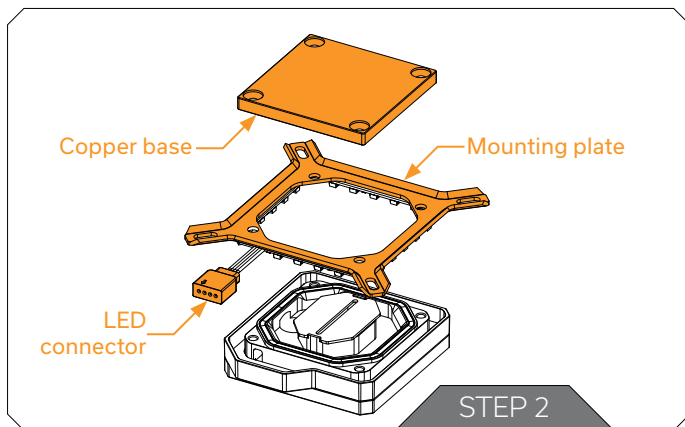

STEP 2

After the removal of screws, take off the Copper base and the Mounting plate with preinstalled LED from the CPU water block. Please store the Copper base for later use.

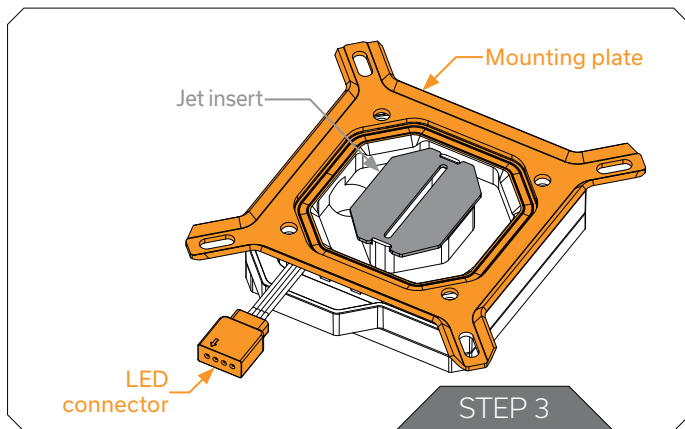

STEP 3

Take the Mounting plate and preinstalled LED from the box and carefully attach them to the CPU water block. Make sure that screws-holes are aligned.

Pay special attention to the insert orientation relative to the copper base and water block top!

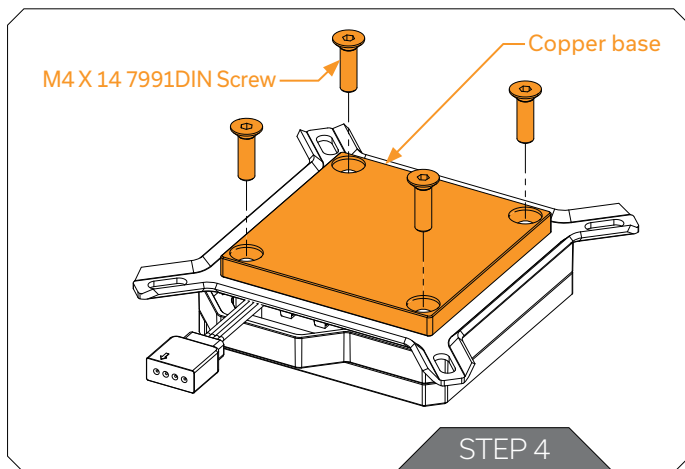

STEP 4

Before reassembly of the water block, it is crucial that the preformed gasket (o-ring) is placed into the gap between the mounting plate and the water block top.

Screw the four (4) screws back in but don't overdo it with the force.

CONNECTING THE RGB LED STRIP

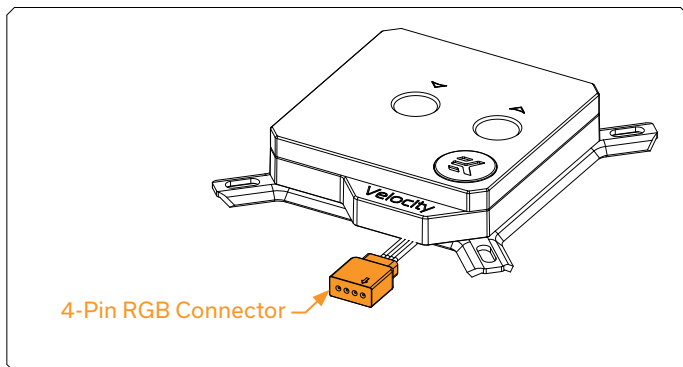

STEP 1

Plug the 4-pin connector from water block's and fan's RGB LED light to the RGB HEADER on the motherboard. The LED will work if the pin layout on the header is as follows: **+12V G R B**.



Please ensure that the arrow indicated on the connector is plugged into the +12V line as indicated on your motherboard.

Failure to do so, will damage your motherboard or LED strip.

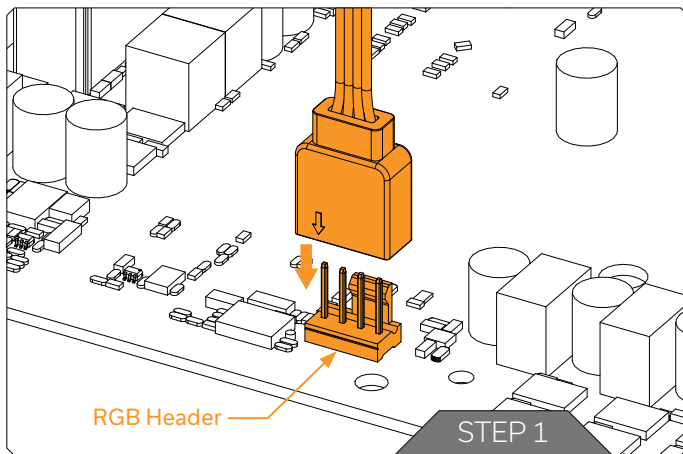

CONNECTING THE D-RGB LED STRIP

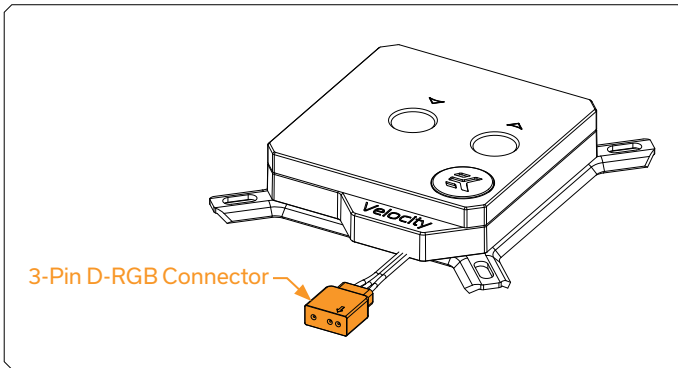

Plug the 3-pin connector from the water block's D-RGB LED light in the D-RGB HEADER on the motherboard. The LED will work if the pin layout on the header is as follows: +5V, Digital.



Please ensure that the arrow indicated on the connector is plugged into the +5V line as indicated on your motherboard. **If you put LED Diode to the 12V RGB HEADER you can damage the LEDs.**

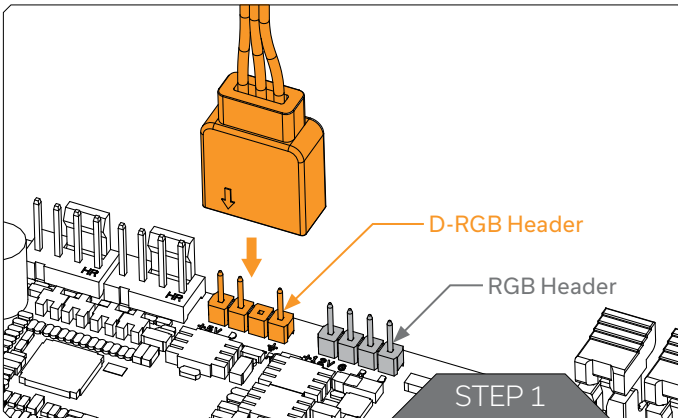

SUPPORT AND SERVICE

For assistance please contact:

<http://support.ekwb.com/>

EKWB d.o.o.
Pod lipami 18
1218 Komenda
Slovenia - EU

SOCIAL MEDIA

 EKWaterBlocks

 @EKWaterBlocks

 ekwaterblocks

 EKWBofficial

 ekwaterblocks

