



Installation and mounting manual for EK-FB ASUS M6I water block:

This product is intended for installation only by expert users. Please consult with a qualified technician for installation. Improper installation may result in damage to your equipment. EK Water Blocks assumes no liability whatsoever, expressed or implied, for the use of these products, nor their installation. The following instructions are subject to change without notice. Please visit our web site at www.ekwb.com for updates. Before installation of this product please read important notice, disclosure and warranty conditions printed on the back of the box.

Before you start using this product please follow these basic guidelines:

1. Please carefully read the manual before through before beginning with the installation process!
2. Please remove your motherboard from the computer to assure safest mounting process in order to prevent any possible damages to your CPU and/or motherboard's circuit board (PCB).
3. The EK High Flow and EK-CSQ type fittings require only a small amount of force to screw them firmly in place since the liquid seal is ensured by the rubber o-ring gaskets.
4. The use of quality, market proved corrosion inhibiting coolants is always strongly recommended for any liquid cooling system.

STEP 1: GENERAL INFORMATION Sample photo of ASUS Maximus VI IMPACT motherboard

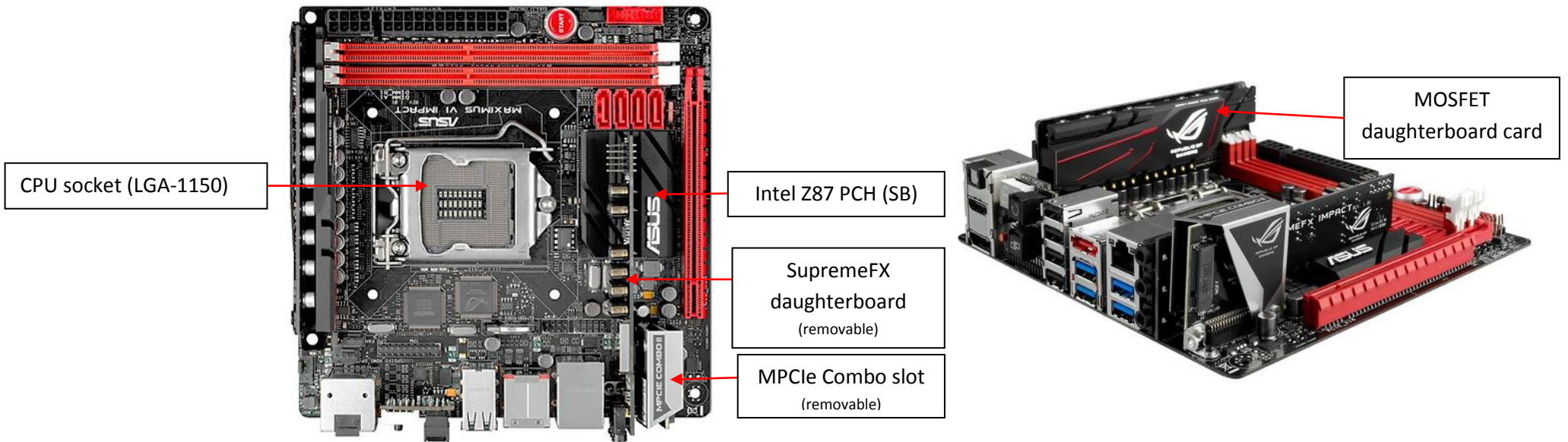

STEP 2: REMOVING THE ORIGINAL LATCH MECHANISM BACKPLATE

Please remove your motherboard from the computer to assure safest mounting process possible in order to prevent any possible damages to your PCB. With the enclosed Torx T20 key please remove the three screws securing the socket latch mechanism (ILM) and original backplate (BP) to the motherboard. **Make sure you have install the plastic cover over the socket pins during this procedure!**

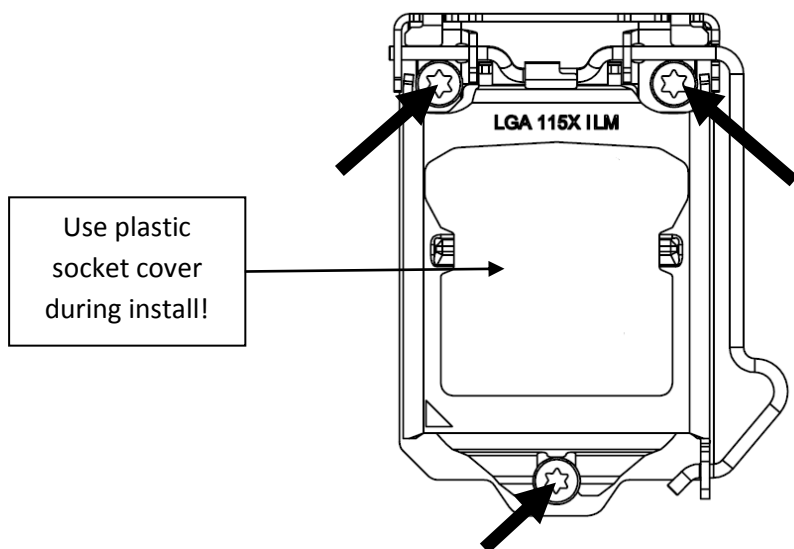

STEP 3: INSTALLING THE EK-LGA115x TRUE BACKPLATE

Align the EK-LGA115x TRUE backplate and it's washer to the backside of the motherboard. Apply corrections to the EK-LGA115x Backplate until all seven openings line up perfectly.

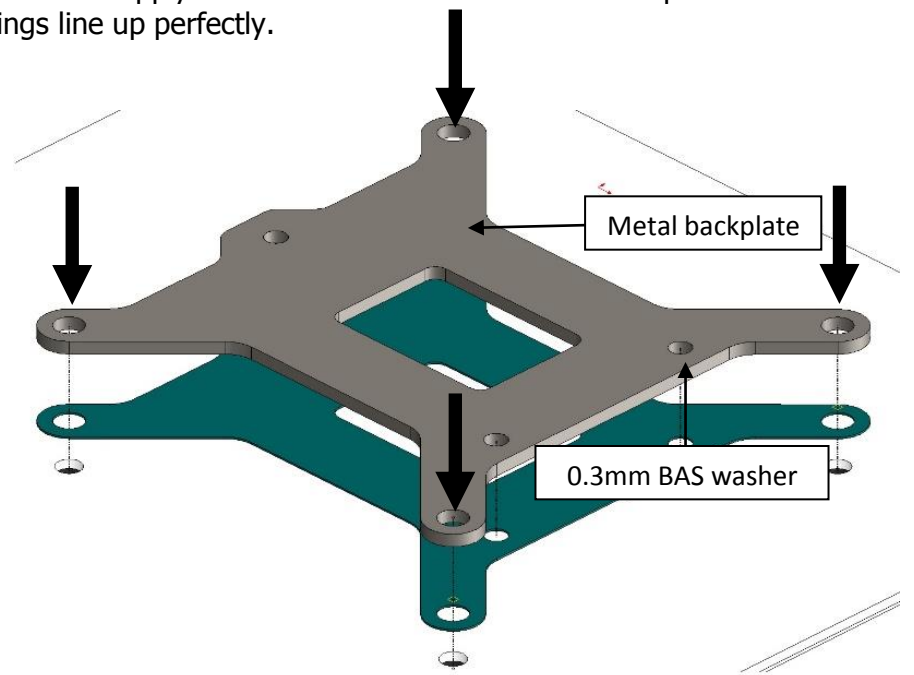

STEP 3 cont: INSTALLING THE EK-LGA115x TRUE BACKPLATE

After the EK-LGA115x TRUE backplate is aligned to the motherboard please re-attach the LGA-115x socket latch mechanism (ILM) to the motherboard using the enclosed Torx T20 key (while tightening the latch screws make sure it stays in the aligned position)! After you have completed all of the above steps you are ready to install your CPU.

Install three original screws using enclosed Torx T20 key!

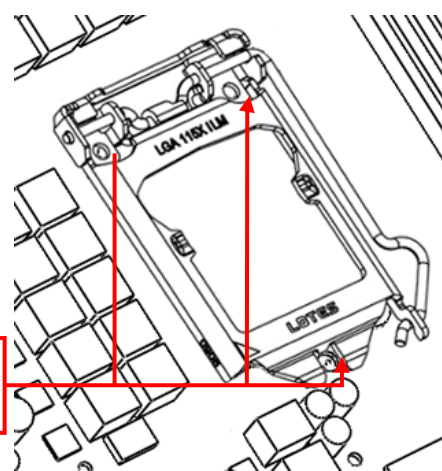

STEP 4: PREPARING YOUR MOTHERBOARD

1. REMOVING STOCK COOLER. Remove all encircled screws. There are 2 screws on the back of the motherboard that needs to be removed in order to remove the factory installed SB heat sink.

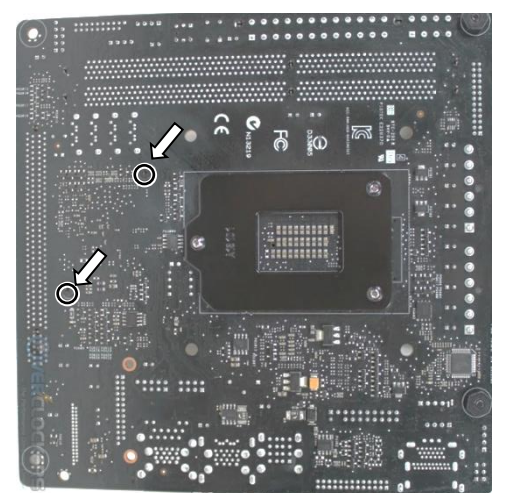

STEP 4 cont: PREPARING YOUR MOTHERBOARD

1. REMOVING STOCK COOLER. Remove all encircled screws. There are 2 screws on the side of the motherboard that needs to be removed in order to remove the factory installed MOSFET heat sink. **DO NOT REMOVE THE FACTORY BACKPLATE.**

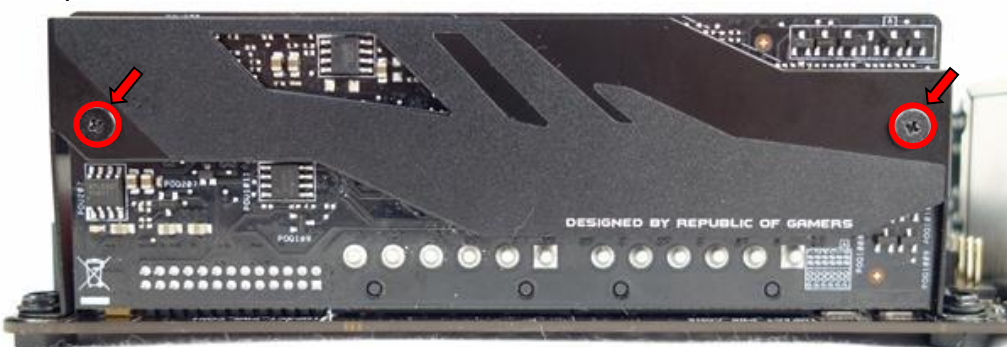

2. CLEANING THE PCB. Carefully detach the original stock cooler after removing all screws securing it to the board. Wipe off the remains (by using non-abrasive cloth or q-tip, as shown on sample photo) of the original thermal compound until the components and circuit board are completely clean. EKWB recommends the use of denatured alcohol for removing TIM leftovers.



3. **APPLYING THERMAL COMPOUND.** Apply thermal compound: lightly coat the Intel Z87 (PCH) – see sample photo on the left and CPU heat spreader (IHS) - see sample photo on right with enclosed EK-TIM Ectotherm thermal grease. The quantity of about two rice grains is just about right. There is no need to cover the whole IHS. Applying too much thermal grease will have negative impact on the cooling performance!

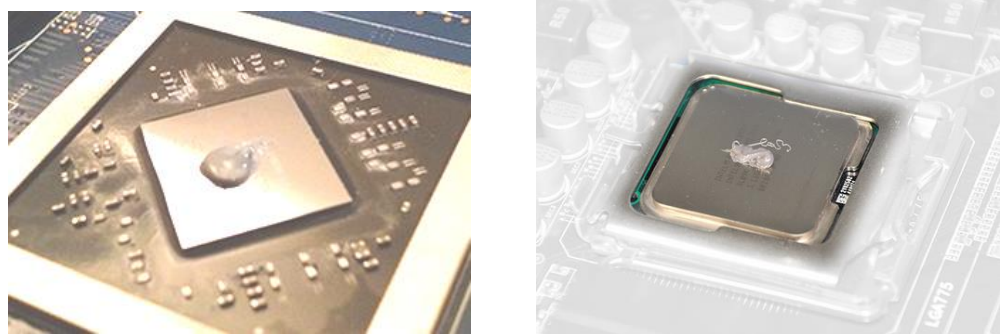

5. **PLACING THERMAL PADS ON MOTHERBOARD.** Place thermal pads you cut on PCB as shown on picture below (PLEASE REMOVE THE PROTECTIVE FOIL FROM BOTH SIDES OF THE THERMAL PADS PRIOR TO INSTALLATION). EK recommends using small drops of electrically non-conductive (for example: EK-TIM Ectotherm, Arctic Cooling MX-2™, MX-4™ or GELID GC-Extreme™) thermal grease on each phase regulator (that is being covered with thermal pad; see picture below) in order to even further improve the thermal performance of the EK-FB ASUS M6I series water block.

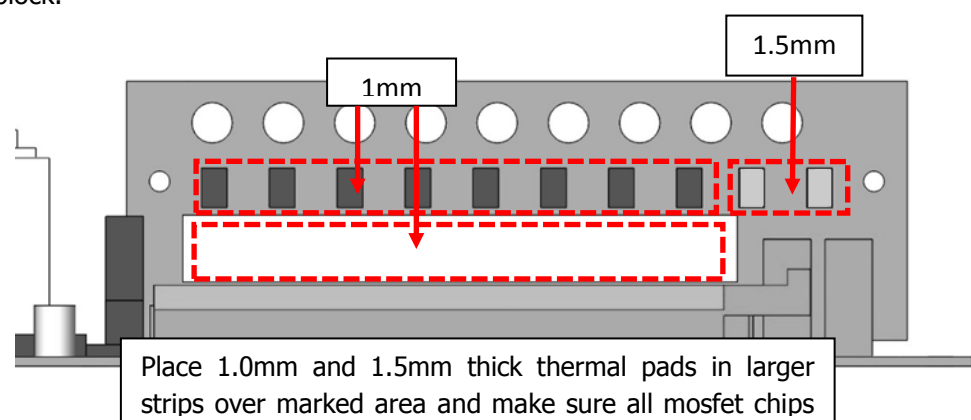

STEP 6: ATTACHING BLOCK TO MOTHERBOARD

Prior to fastening the screws please make sure the mounting holes on the motherboard's circuit board are aligned with the water block.

Use two (2) M2.5x4 DIN7985, two (2) M3x6 DIN7985 and four (4) M4x10 DIN7985 screws as shown in picture below. Use washers underneath each M2.5x4 screw. Do not use excessive force when tightening the screws!

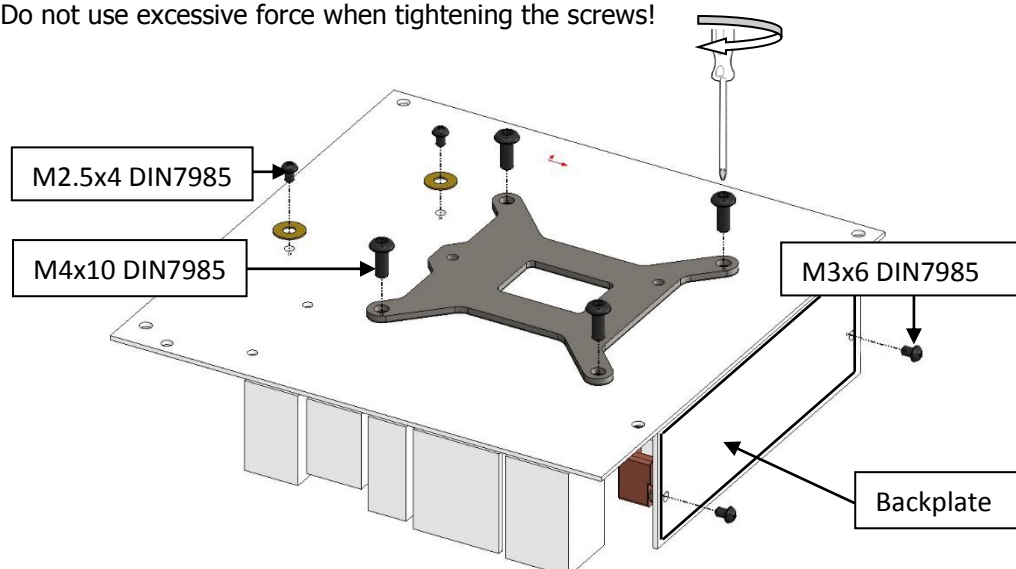

4. **CUTTING THERMAL PADS.** Your block comes with one thermal pads which needs to be trimmed in order to fit the voltage regulation area (VRM/MOSFET) on the motherboard's circuit board. **WARNING: DIMENSIONS ON PICTURES BELOW ARE SCALED**

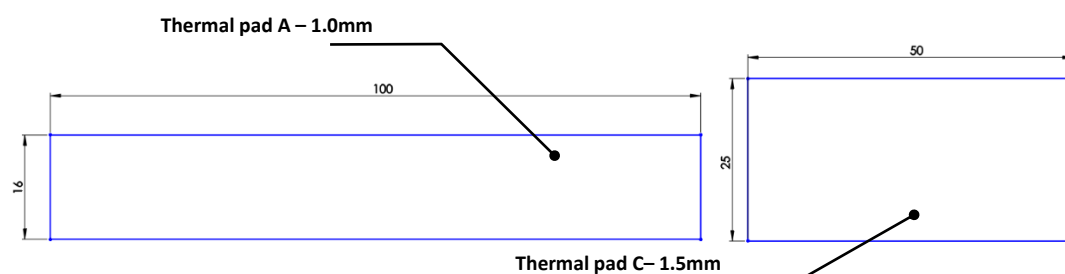

Replacement thermal pads @ EKWB web shop:

Thermal PAD A 1mm - (100x16mm) [EAN: 3830046996626]

STEP 5: PREPARING YOUR WATER BLOCK

1. **PLACING THE BLOCK ON THE MOTHERBOARD.** Place the EK-FB ASUS M6I series water block gently to the motherboard or vice versa (as shown on photo below). Make sure that mounting holes are aligned.

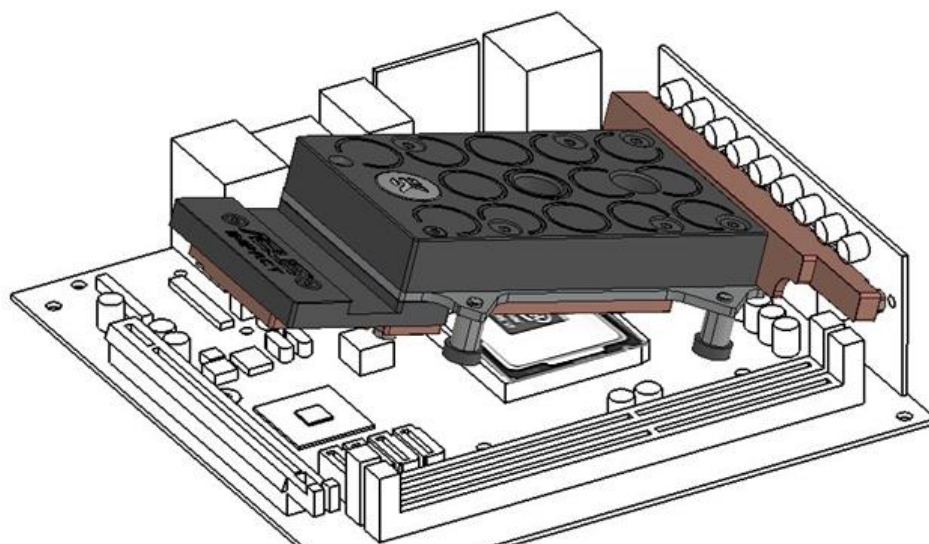

STEP 7: CHECKING FOR CONTACTS

Temporarily remove the water block to check for uniform surface contact between the block and the components. Then repeat steps 5 and 6 to reattach the block applying more or less pressure to the areas where you have found it necessary.

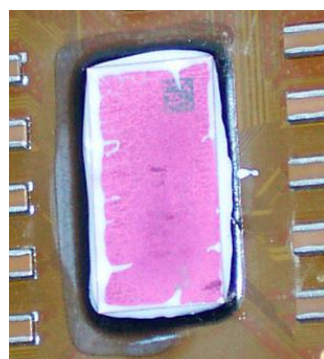

Chip die thermal grea

8. POSITIONING FITTINGS AND CONNECTING TO WATER CIRCUIT

For the EK-FB ASUS M6I series water block to operate properly the G1/4 port nearest to the center of the water block **MUST BE USED AS THE INLET PORT**. EK recommends the use of EK-CSQ fittings. When using fittings other than EK-CSQ series please use hose clamps or appropriate substitute to secure the tubing to the barb. The use of biocide containing and corrosion inhibiting coolant is always recommended for any liquid cooling system.

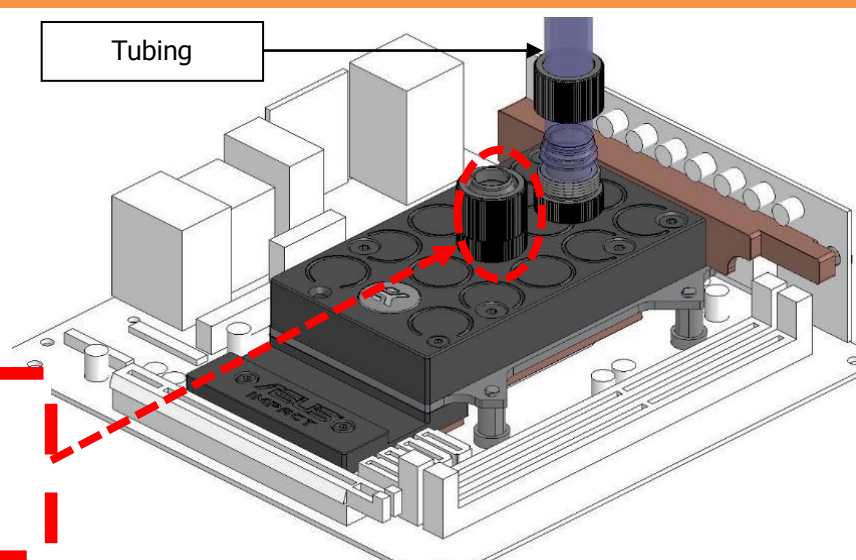

REQUIRED TOOLS AND MOUNTING SCREWS:



scissors



philips screwdriver