



Installation and mounting manual for **EK-FB ASUS Max4 Extreme** water block:

This product is intended for installation only by expert users. Please consult with a qualified technician for installation. Improper installation may result in damage to your equipment. EK Water Blocks assumes no liability whatsoever, expressed or implied, for the use of these products, nor their installation. The following instructions are subject to change without notice. Please visit our web site at www.ekwaterblocks.com for updates. Before installation of this product please read important notice, disclosure and warranty conditions printed on the back of the box or our home page.

The barb hose fittings require only a small amount of force to screw them in; otherwise the high flow fittings might break. These fittings do not need to be tightened with much force because the liquid seal is made using o-rings. The use of an algacide and corrosion inhibitors is always recommended for any liquid cooling system.

STEP 1: GENERAL INFORMATION Sample photo of ASUS Maximus IV Extreme PCB design



STEP 2: PREPARING YOUR MOTHERBOARD

1. REMOVING STOCK COOLER. Remove all 8 screws holding the original heat-pipe cooler / backplate assembly to the motherboard's circuit board.

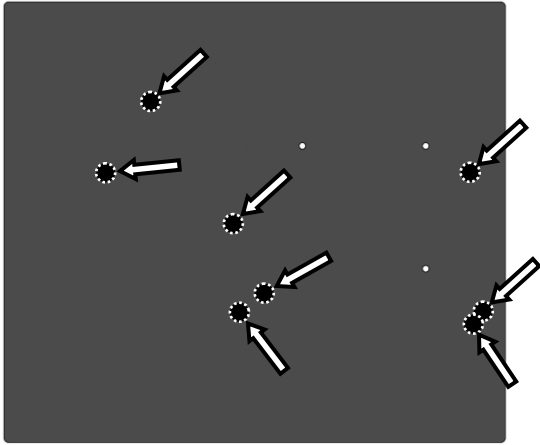

2. CLEANING THE PCB. Carefully detach the original stock cooler after removing **all** screws securing it to the board. Wipe off the remains (by using non-abrasive cloth or qtip, as shown on sample photo) of the original thermal compound until the components and circuit board are completely clean. EKWB does not recommend using any liquids for removing paste.



3. APPLYING THERMAL COMPOUND

Apply thermal compound: lightly coat the NF200 (NB) and P67 PCH (SB chips with for example Arctic Cooling MX-2™ or MX-4™ thermal grease. EKWB recommends to apply thermal grease in cross form for best performance (see sample picture).

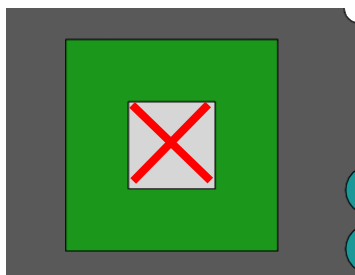

4. CUTTING THERMAL PADS. Two (2) 90x15x1mm thermal pads are enclosed with your EK-FB Max4 Extreme water block. You will have to cut the thermal pad in order to cover all marked surfaces surface. (WARNING: DIMENSIONS ON PICTURES BELLOW ARE SCALED!)

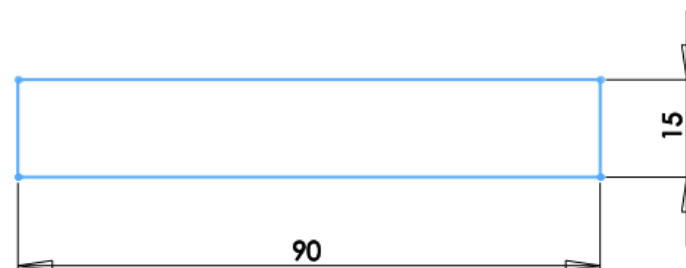

5. PLACING THERMAL PADS ON MOTHERBOARD. Place thermal pads you cut on PCB as shown on picture bellow. (PLEASE REMOVE FOIL OF THERMAL PADS ON BOTH SIDES PRIOR TO INSTALLATION.)

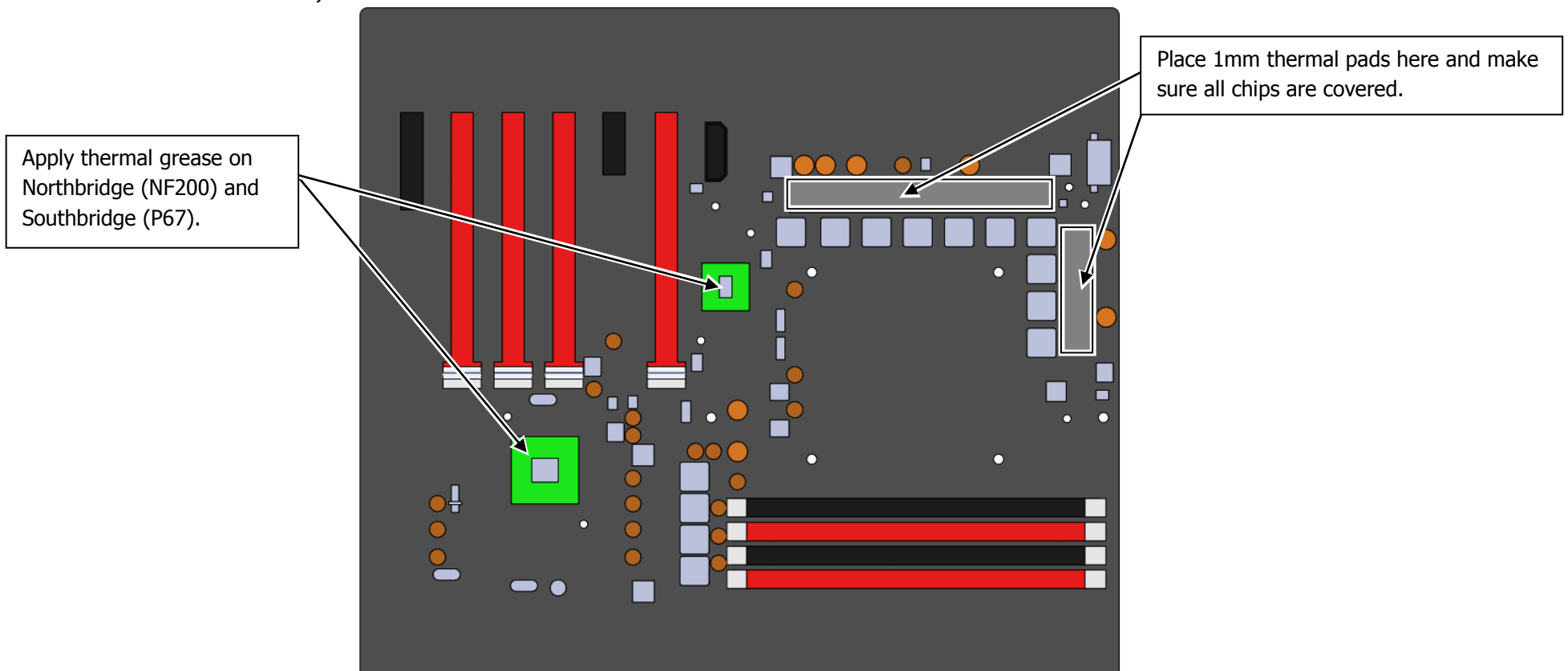

STEP 3: PREPARING YOUR WATER BLOCK

1. ATTACHING STANDOFFS. Apply small amount of thermal grease around mounting holes and place acetal standoffs on NB & MOSFET part of the waterblock (thickness 2,1 mm) so the holes are concentric. Use two 3,3mm acetal standoffs on the SB part of the waterblock to make one 6,6mm standoff. Thermal paste provides enough adhesive force for standoffs to stay in a place for easier installation. This is a crucial step!

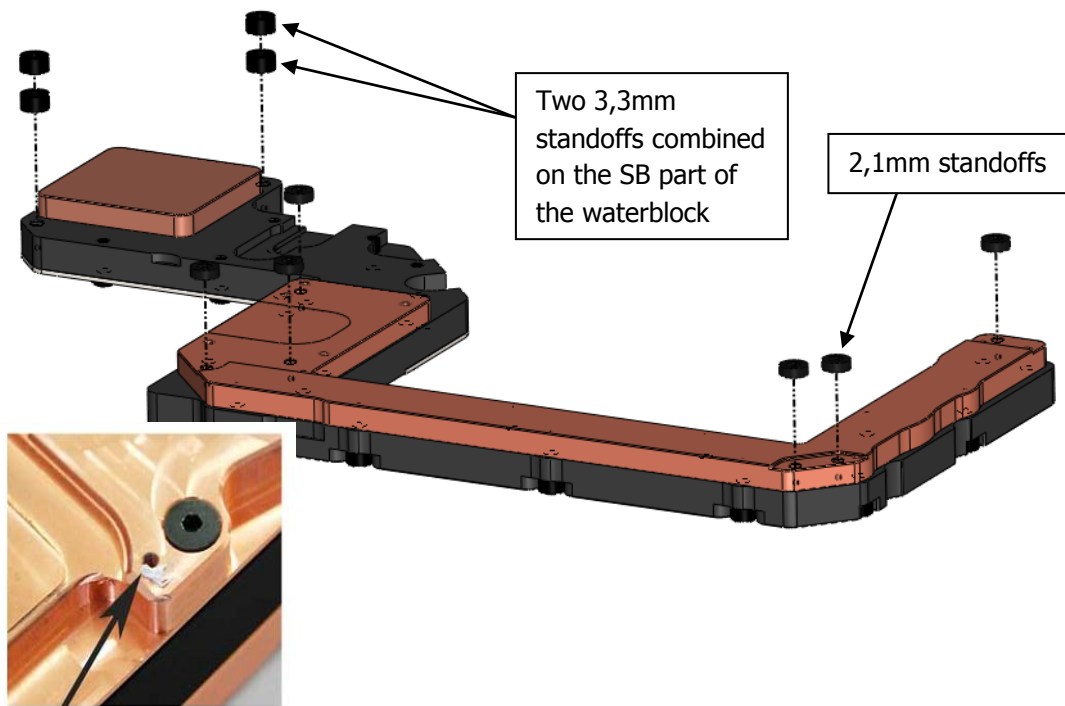

2. PLACING BLOCK OVER MB. Place the motherboard on the inverted water blocks or vice versa and attach them with enclosed screws as shown. Make sure that mounting holes are aligned.

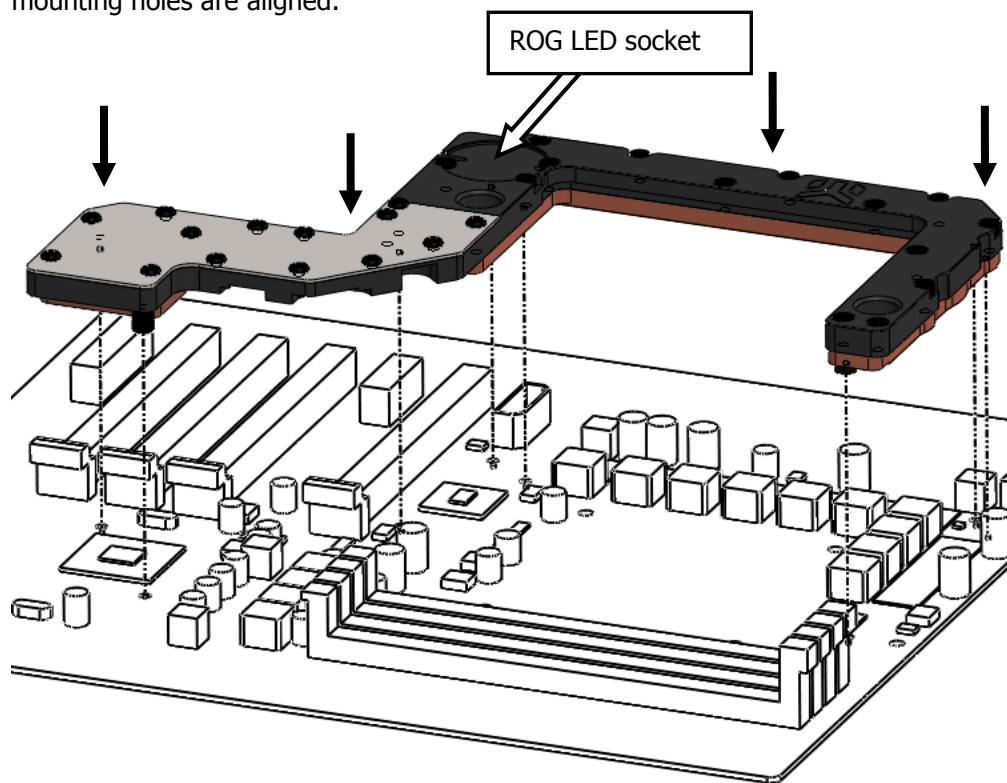

STEP 4: ATTACHING BLOCK TO MOTHERBOARD

MOUNTING THE BLOCK. For perfect thermal contact, the block does not use a spring mounting system; therefore when attaching be very careful to tighten all screws equally. **Tightening the screws beginning in the center of the block near the northbridge, and continue evenly outwards. Do not use too much pressure on screws, because motherboard might bend and either cause bad contact with water block, or break a connection on the circuit board.**

Use the enclosed screws and washers as shown in diagram below:

Use two (2) enclosed M3x12 DIN7985 screws on the southbridge part of the waterblock!

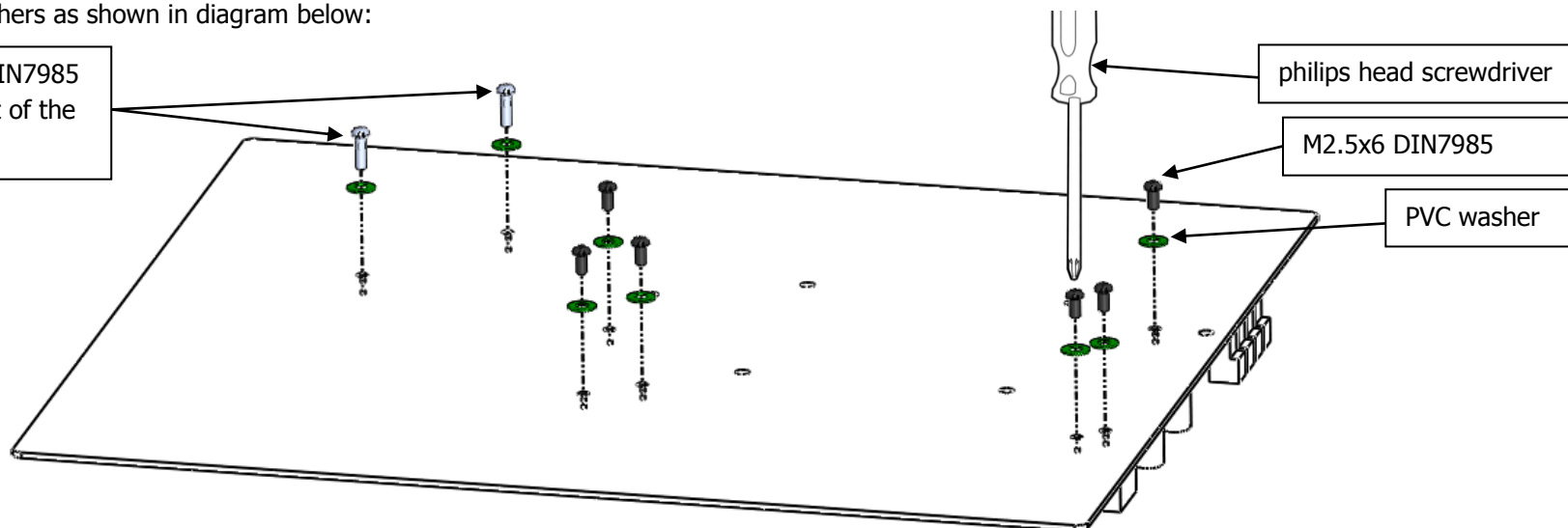

STEP 5: CHECKING FOR CONTACTS

Temporarily remove the water block to check for uniform surface contact between the block and the components. Note the pattern of contact on a piece of paper. Then repeat steps 3 and 4 to reattach the block. Block was tested on physical hardware. Due to height variations of chipset some differences may occur. In case you have problem with block contacts please write to our support mail.

STEP 6: POSITIONING FITTINGS AND CONNECTING TO WATER CIRCUIT

Screw in fittings as shown in picture, attach the liquid cooling tubes and connect the water-block(s) into the cooling circuit. Please use spacer if you use fitting with G1/4 thread longer than 5mm. Attach the liquid cooling tubes and connect the water-block(s) into the cooling circuit. EKWB recommends using EK-PSC compression fittings with the EK-FB Max4 Extreme series water blocks. The use of an market proved algacide is always recommended for any liquid cooling system. You can use any opening as an inlet/outlet port.

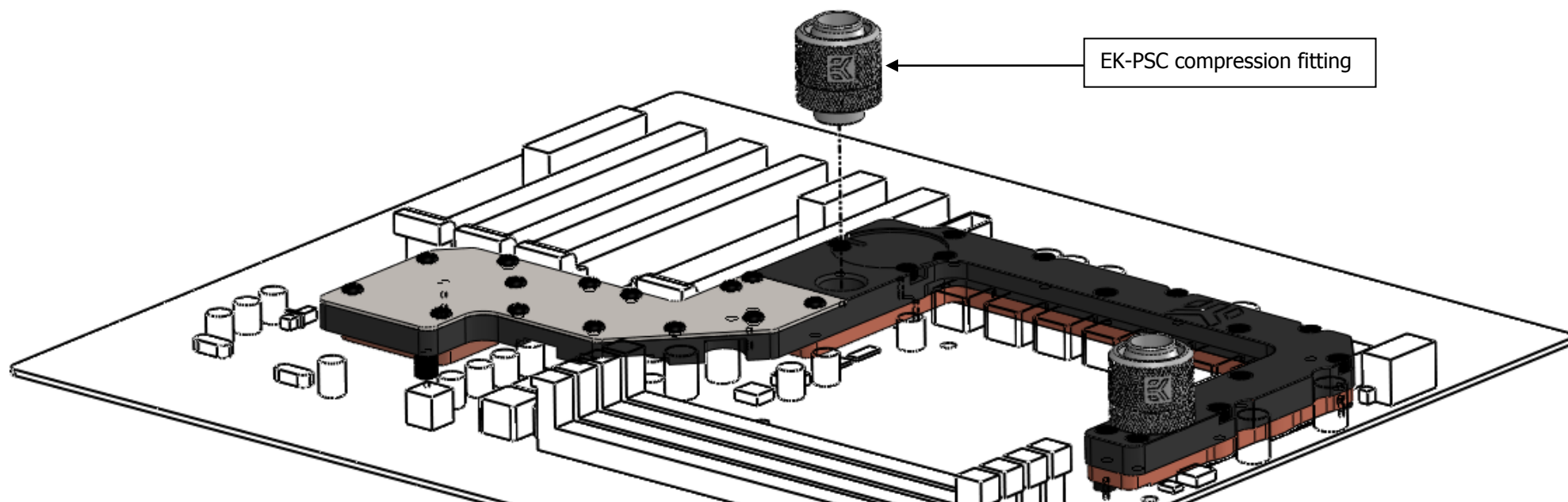

REQUIRED TOOLS AND MOUNTING SCREWS:

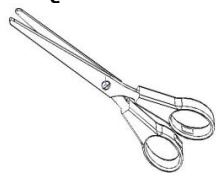

scissors



philips screwdriver



6 screws M2.5x6 DIN7985

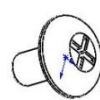

2 screws M3x12 DIN7985



8 PVC washers