

This product is intended for installation only by expert users. Please consult with a qualified technician for installation. Improper installation may result in damage to your equipment. EK Water Blocks assumes no liability whatsoever, expressed or implied, for the use of these products, nor their installation. The following instructions are subject to change without notice. Please visit our web site at www.ekwaterblocks.com for updates. Before installation of this product please read any important notice, disclosure and warranty conditions printed on the back of the box and on EKWB home page.

EKWB recommends using EK-PSC fittings which require a small amount of force to screw them in; otherwise fittings might break or damage your block. These fittings do not need to be tightened with much force because the liquid seal is made using rubber gaskets. EKWB does not recommend use of distilled water only in mixed metals loops, thus use of corrosive inhibitors is highly recommended.

STEP 1: GENERAL INFORMATION. Sample picture of ASUS X99 motherboard.



STEP 2: PREPARING YOUR MOTHERBOARD

1. REMOVING STOCK COOLER. Remove all eight (8) screws pins holding the MOSFET heat-sink assembly. MOSFET heat sink as well as stock backplate should be removed.

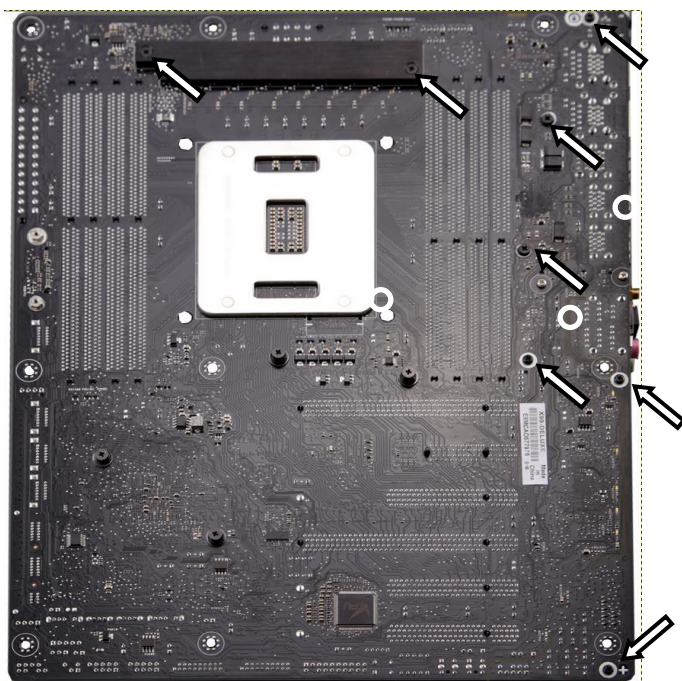

2. CUTTING THERMAL PADS. Your block comes with two pre-cut thermal pads type A: 0.5mm (100x16mm) and 1mm (100x16mm), which have to be trimmed and placed on MOSFET chips. EK recommends using small drops of electrically non-conductive (for example: Arctic Cooling MX-2™ or MX-4™) thermal grease on each phase regulator (that is being covered with thermal pad; see picture below) in order to even further improve the thermal performance of the water block.

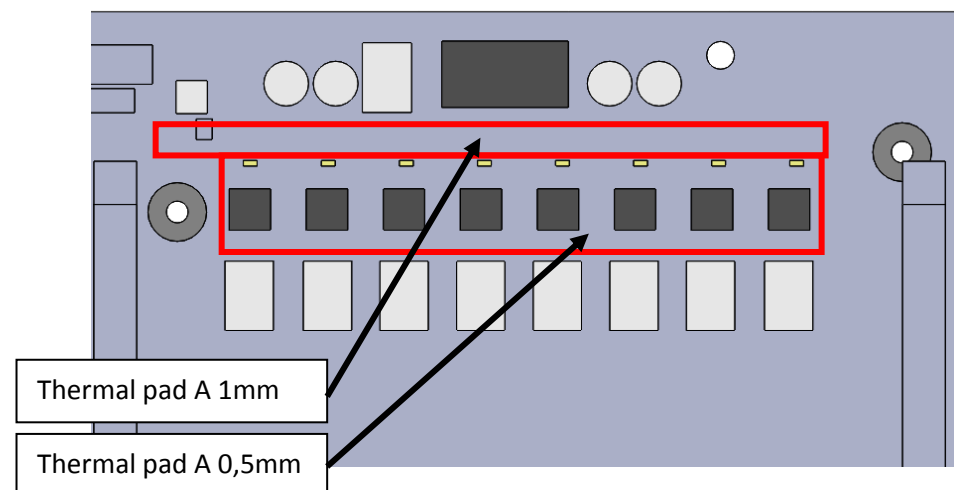

STEP 3: PREPARING YOUR WATERBLOCK

PLACING WATERBLOCK ON MOTHERBOARD. Place waterblock on VRM section of the motherboard's circuit board as shown on picture below:

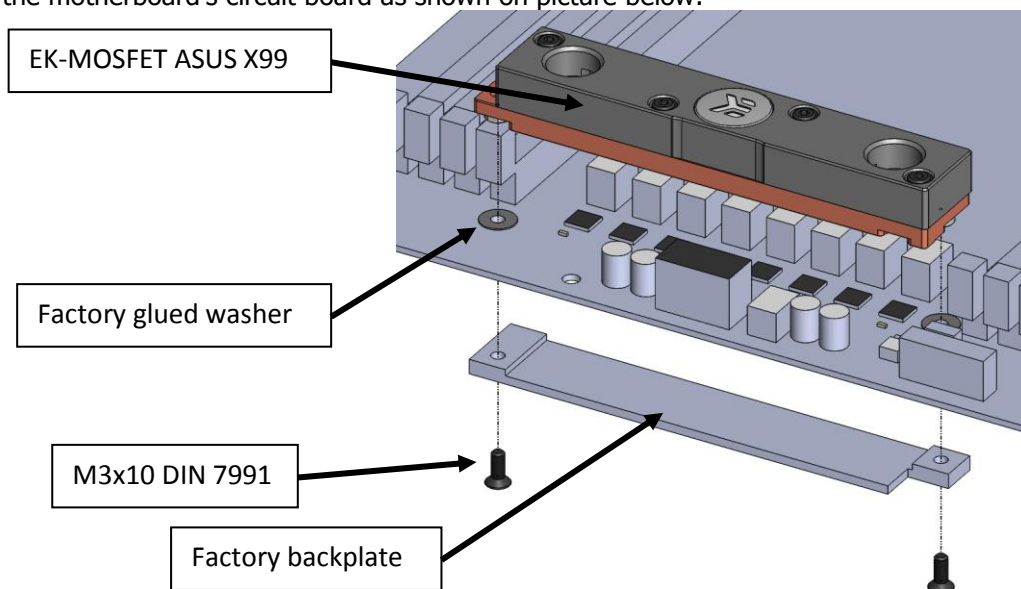

ATTACHING WATERBLOCK/BACKPLATE ON MOTHERBOARD. When waterblock is safely placed on motherboard, please align the openings and fasten the waterblock to factory backplate using the enclosed M3x10 DIN7991 screws to the motherboard's circuit board. It is recommended that you check for unwanted contacts before powering up the system.

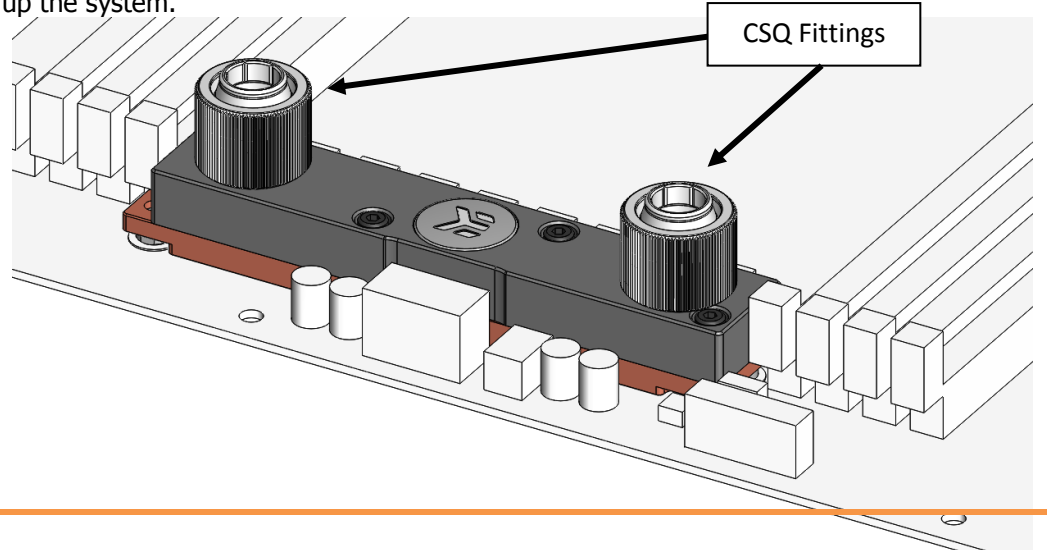

REQUIRED TOOLS AND MOUNTING SCREWS:

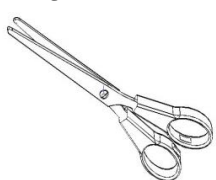

scissors



philips screwdriver

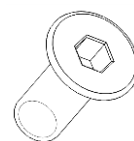

2x screws M3x10 DIN7991