

This product is intended for installation only by expert users. Please consult with a qualified technician for installation. Improper installation may result in damage to your equipment. EK Water Blocks assumes no liability whatsoever, expressed or implied, for the use of these products, nor their installation. The following instructions are subject to change without notice. Please visit our web site at [www.ekwb.com](http://www.ekwb.com) for updates. Before installation of this product please read important notice, disclosure and warranty conditions printed on the back of the box.

Before you start using this product please follow these basic guidelines:

1. Please carefully read the manual before through before beginning with the installation process!
2. The EK High Flow and EK-PSC type fittings require only a small amount of force to screw them firmly in place since the liquid seal is ensured by the rubber o-ring gaskets.
3. The use of corrosion inhibiting coolants is highly recommended for any liquid cooling system to prevent corrosion.

## Presenting UNI Pump Holder which can be mounted on 120mm fan

The holder supports following pumps without additional accessories:

- EK-XTOP Rev0 D5 series pump tops
- EK-XRES Rev0 D5 series pump tops

Following pumps are supported with additional accessories:

- EK-DDC X-Top series pump tops
- EK-DDC X-Res series pump tops
- EK-DDC Anti-Vibration Mounting (EAN: 3831109871560)
- EK-DDC Heatsink Housing (EAN: 3831109862674 & 3831109862667)
- EK-UNI Holder DDC V2 (EAN: 3830046997951)

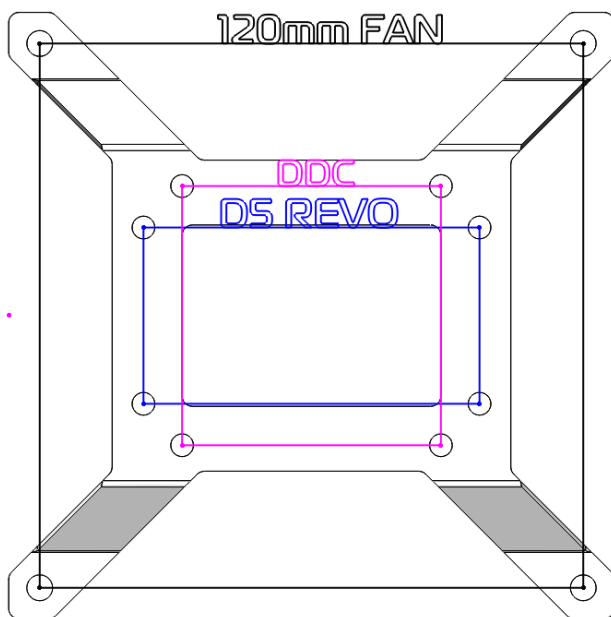

## STEP 1: INSTALLING UNI Pump Holder - EK-XRES 100 Rev0 D5

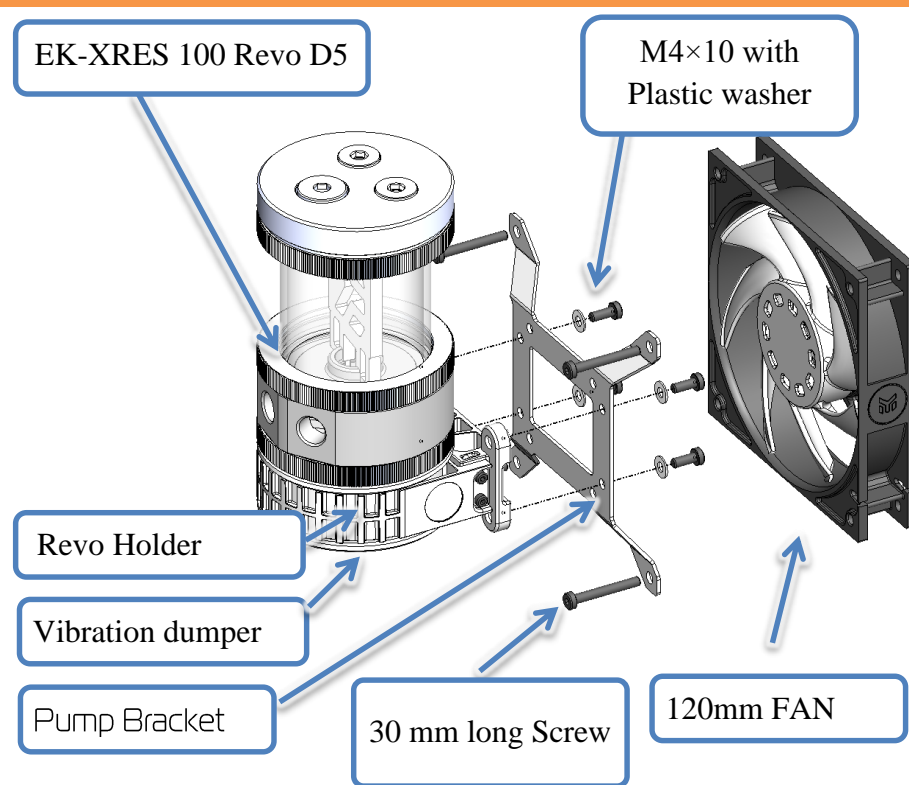

## STEP 1: Presenting UNI Pump Holder which can be mounted on fan

## INSTALLING UNI Pump Holder – EK-XTOP Rev0 D5

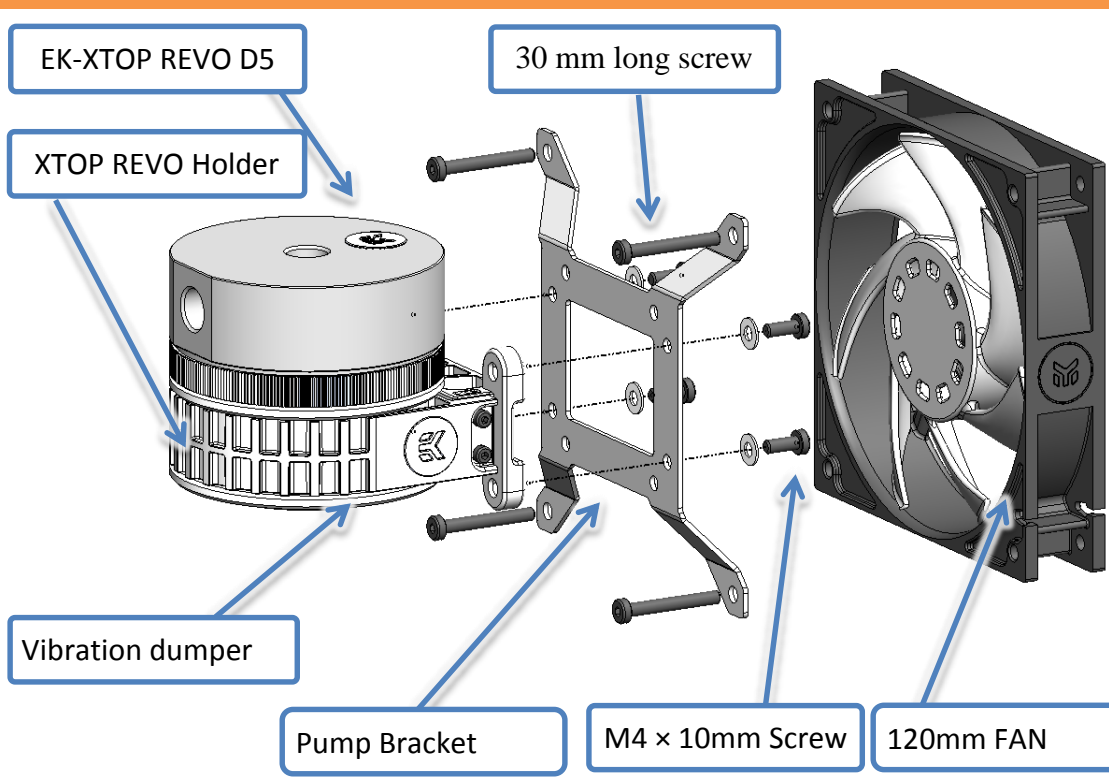
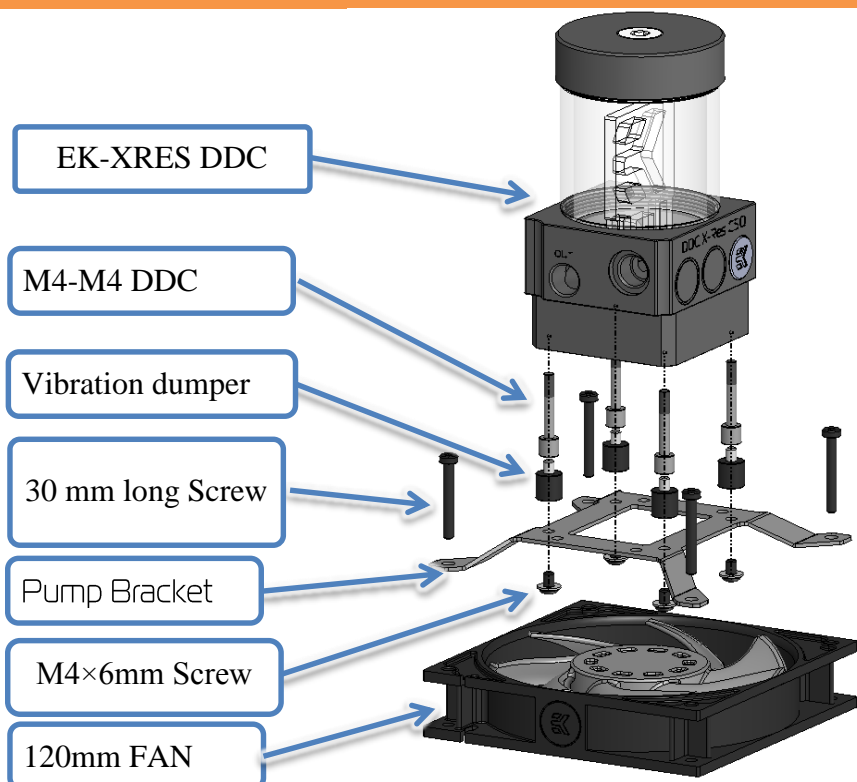

## OTHER INSTALLATION OPTIONS:

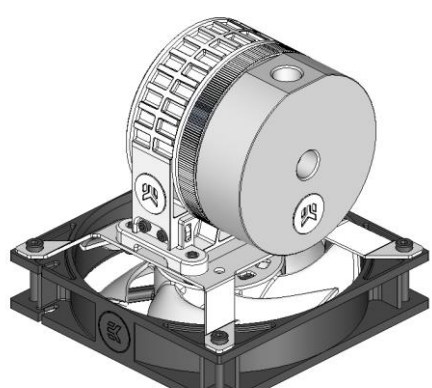

XTOP Rev0 D5 on horizontal FAN

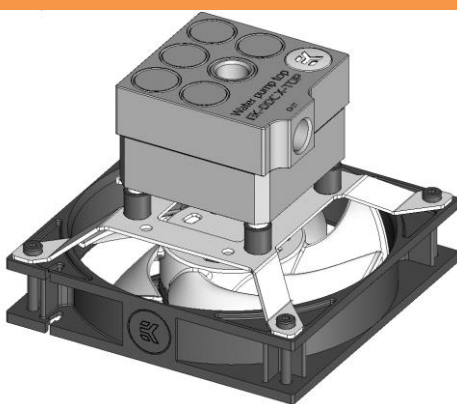

XTOP DDC on horizontal FAN

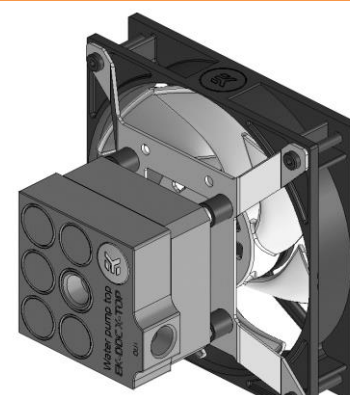

XTOP DDC on vertical FAN

## IMPORTANT DISCLOSURES:

**WARRANTY:** Our products are warranted against defects in materials or workmanship for a period of 24 months beginning from the date of delivery to the final user. During this period, products will be repaired or have parts replaced at our discretion provided that: (I) the product is returned to the agent from whom it was purchased; (II) the product has been purchased by an end user and has not used for commercial purposes; (III) the product has not been misused, handled carelessly, or used in a manner other than in accordance with the instructions provided describing its installation and proper use. This warranty does not confer rights other than those expressly set out above and does not cover any claims for consequential loss or damage. This warranty is offered as an extra benefit and does not affect your statutory rights as a consumer. This warranty is voided if the product comes in contact with aggressive UV additives or other improper liquids.

Any other RMA issues can be reported to [www.ekwb.com/support](http://www.ekwb.com/support) for further analysis.

**REQUIRED TOOLS:** Allen Key 2,5mm (enclosed)