

This product is intended for installation only by expert users. Please consult with a qualified technician for installation. Improper installation may result in damage to your equipment. EK Water Blocks assumes no liability whatsoever, expressed or implied, for the use of these products, nor their installation. The following instructions are subject to change without notice. Please visit our web site at www.ekwaterblocks.com for updates. Before installation of this product please read important notice, disclosure and warranty conditions printed on the back of the box.

The barb hose fittings require only a small amount of force to screw them in; otherwise the high flow fittings might break. These fittings do not need to be tightened with much force because the liquid seal is made using o-rings.

STEP 1: GENERAL INFORMATION

EKWB recommends the use of enclosed retention UNIVERSAL backplate. When having it installed, you can use higher mounting force. Therefore you can compress springs more than without retention back plate. With retention back plate you will achieve better temperatures on your CPU. If you don't have installed retention back plate, please be very careful when tightening thumb nuts due to motherboards PCB bending. If it bends too much motherboard might get damaged.

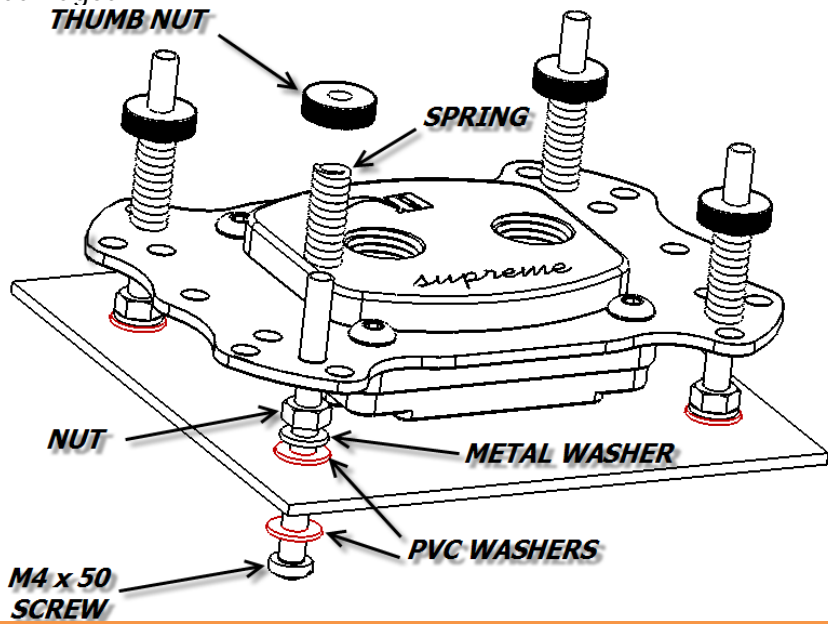

STEP 2: ATTACHING BACKPLATE for Intel 775 Socket

When using motherboard with Intel 775 socket, insert screws at positions as shown bellow. EPDM rubber is used as insulator, therefore it must be used underneath the metal backplate.

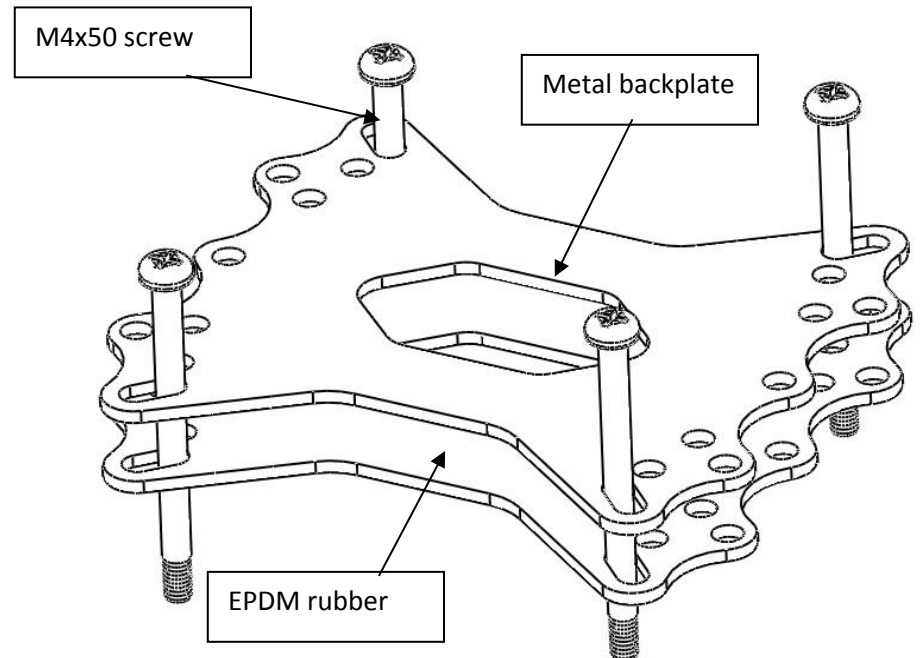

STEP 3: ATTACHING BACKPLATE for Intel 1366 Socket

When using motherboard with Intel 1336 socket, insert screws at positions as shown bellow. EPDM rubber is used as insulator, therefore it must be used underneath the metal backplate. Standoffs are used to prevent possible overtightening of screws and causing potential damage to PCB.

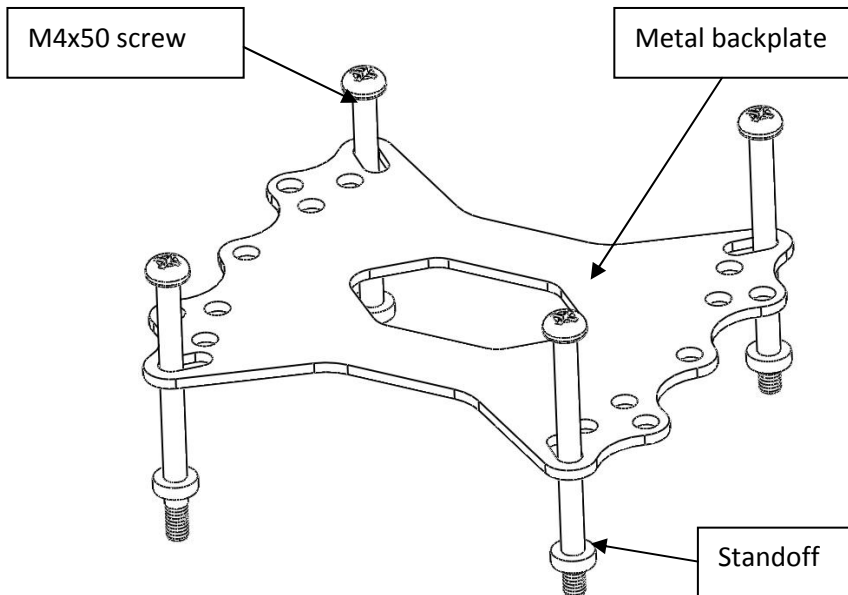

STEP 4: ATTACHING BACKPLATE for AM2, AM2+ and AM3 Socket

When using motherboard with AM2 and AM3 socket, insert screws at positions as shown bellow. EPDM rubber is used as insulator, therefore it must be used underneath the metal backplate.

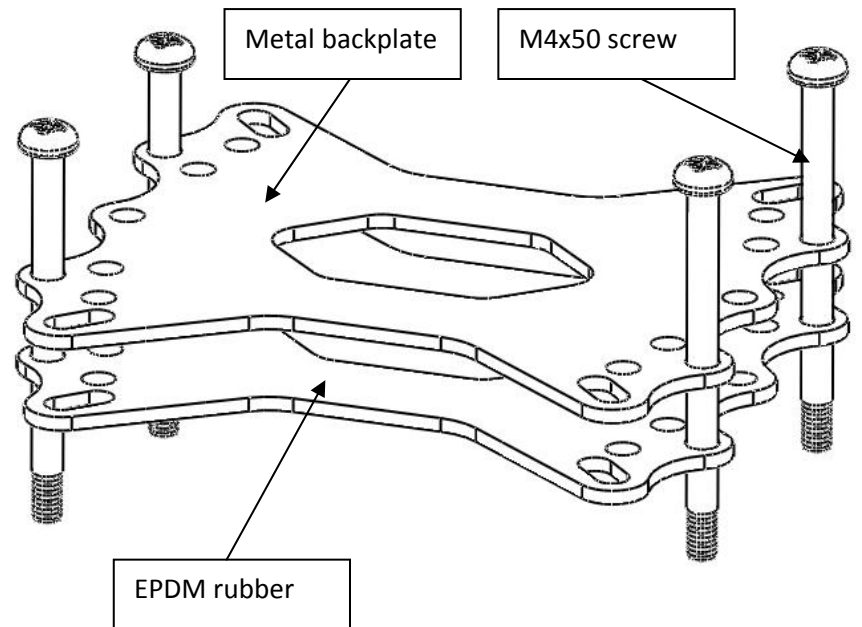

STEP 5: ATTACHING BACKPLATE for Intel 1156 Socket

When using motherboard with Intel 1156 socket, insert screws at positions as shown bellow. Standoffs are used to prevent possible overtightening of screws and causing potential damage to PCB.

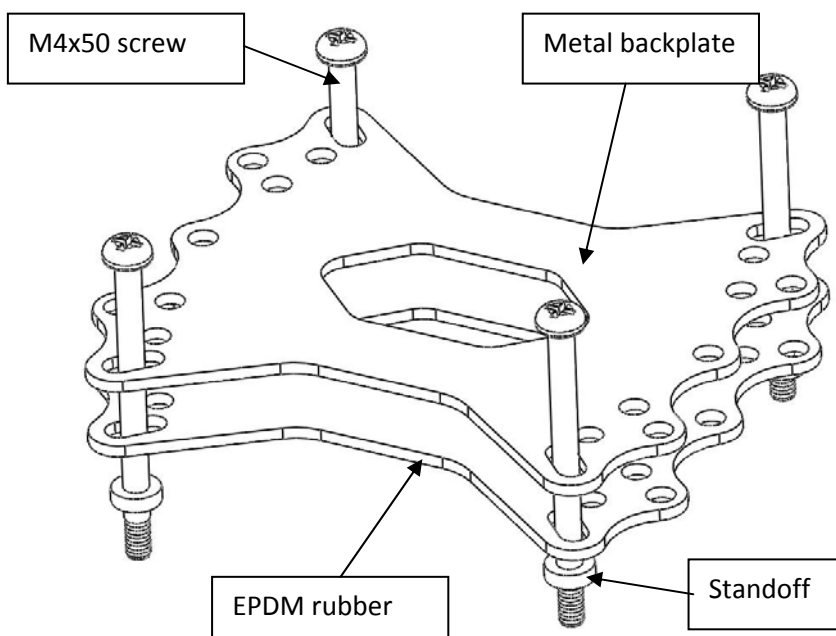

IMPORTANT DISCLOSURES

VERY IMPORTANT NOTICE: Once the installation is completed, it is a recommended practice to test the cooling circuit for leaks prior to powering up the computer. We recommend a 24 hour leak test prior to powering up the computer. Do not test the water block using city water pressure. This will rupture the top of the housing and render the block unusable (and will void your warranty).

While all efforts have been made to provide the most comprehensive tutorial possible, EK Water Blocks assumes no liability expressed or implied for any consequential damage(s) occurring to your equipment as a result of using EK Water Blocks cooling products, either due to errors or omissions on our part in the above instructions, or due to failure or defect in the EK Water Blocks cooling products.

WARRANTY:

Our products are warranted against defects in materials or workmanship for a period of 24 months beginning from the date of delivery to the final user. During this period, products will be repaired or have parts replaced at our discretion provided that: (I) the product is returned to the agent from whom it was purchased; (II) the product has been purchased by an end user and has not used for commercial purposes; (III) the product has not been misused, handled carelessly, or used in a manner other than in accordance with the instructions provided describing its installation and proper use. This warranty does not confer rights other than those expressly set out above and does not cover any claims for consequential loss or damage. This warranty is offered as an extra benefit and does not affect your statutory rights as a consumer. This warranty is voided if the product comes in contact with aggressive UV additives.