

## Installation and mounting manuals for EK-FC 285 GTX Rev.2 water block:

This product is intended for installation only by expert users. Please consult with a qualified technician for installation. Improper installation may result in damage to your equipment. EK Water Blocks assumes no liability whatsoever, expressed or implied, for the use of these products, nor their installation. The following instructions are subject to change without notice. Please visit our web site at [www.ekwaterblocks.com](http://www.ekwaterblocks.com) for updates.

**The barb hose fittings require only a small amount of force to screw them in. Otherwise the high flow fittings might break. These fittings do not need to be tightened with much force because the liquid seal is made using o-rings.**

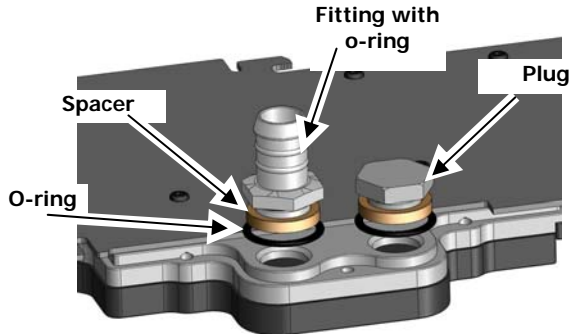

*Picture 1: Sample picture of fitting installation*

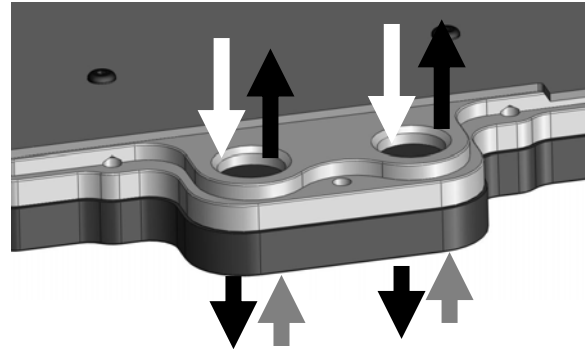

*Picture 2: Any hole can be used as inlet hole, and any hole can be used as outlet hole. Hole on opposite side has to be plugged with enclosed G1/4 plug.*

**Step 1.** Remove the graphic card from computer.

**Step 2.** Carefully detach the original heat sink after removing all fasteners securing it to the board and bracket. Wipe off the remains of the original thermal compound until the components and circuit board are completely clean.

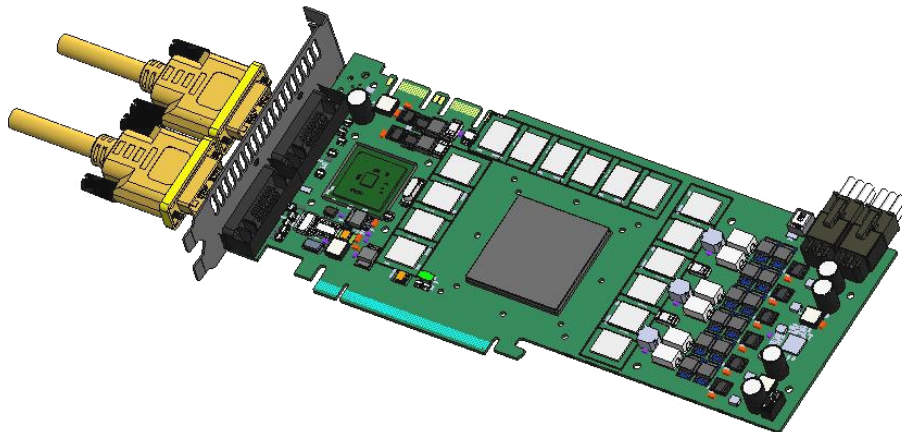

*Picture 3: Sample picture of disassembled GTX285 rev.2 (Zotac PCB design)*

Unscrew all 12 encircled screws in circles and store them.

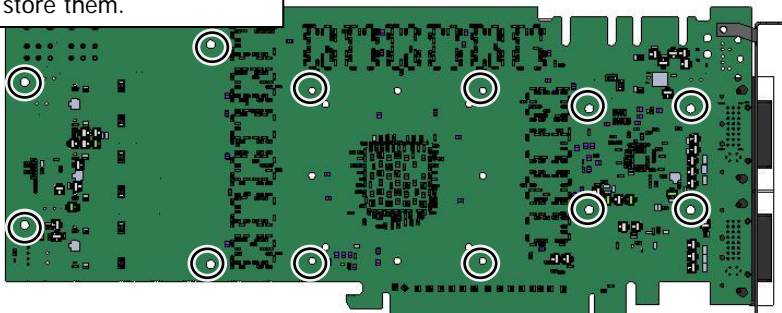

*Picture 4: Removing the stock cooler*

Unscrew 2 screws to remove the stock cooler.

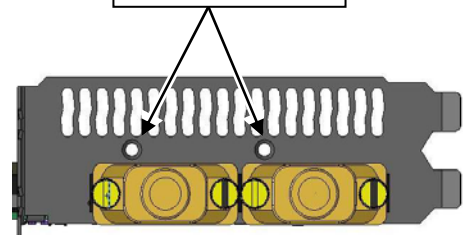

*Picture 5: Removing the stock cooler*

**Step 3.** Apply thermal compound: lightly coat the GPU, RAMs and with for example Céramique™ thermal compound. Follow this link [http://www.arcticsilver.com/ceramique\\_instructions.htm](http://www.arcticsilver.com/ceramique_instructions.htm) for detailed instructions. EK Water Blocks recommends non-conductive Arctic Silver Céramique™ or MX-2.

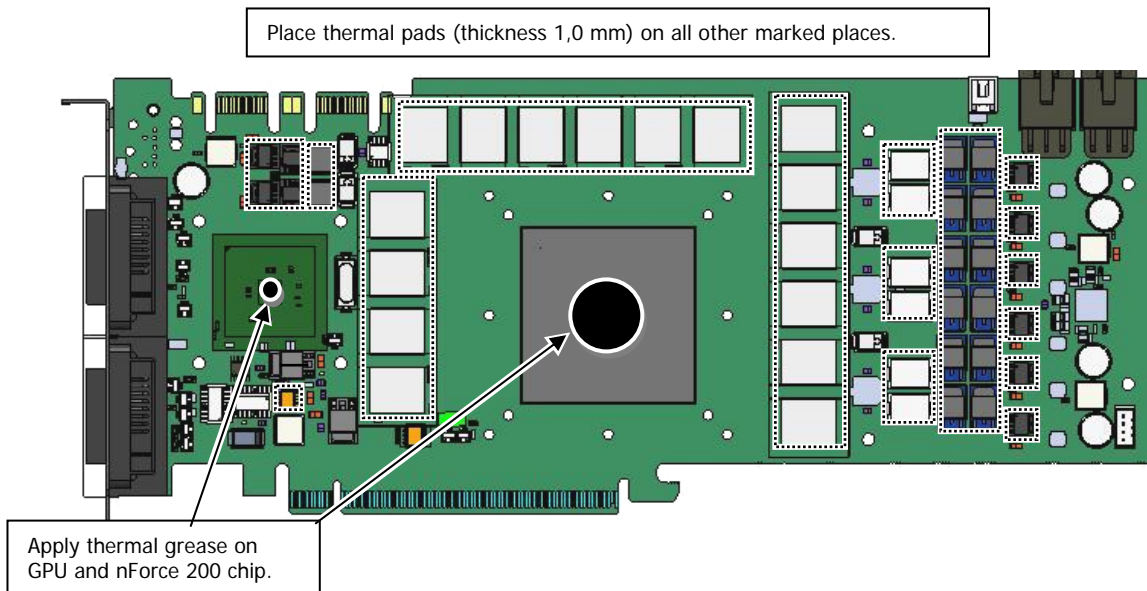

**Picture 6:** Applying thermal compound on Graphic card Zotac 285 GTX

**Step 4.** Place the graphic card on the inverted water block and attach it with enclosed screws as shown in picture 8. For perfect thermal contact, the block does not use a spring mounting system; therefore when attaching without standoffs be very careful to tighten all screws equally. If the screws are tightened too much, when not using standoffs, the graphic card board will bend and could get damaged. To prevent warping of card please use enclosed standoffs and apply them as shown on pictures bellow. Prior aligning standoffs with mounting holes, please apply small amount of thermal grease around the thread to fix the enclosed standoffs.

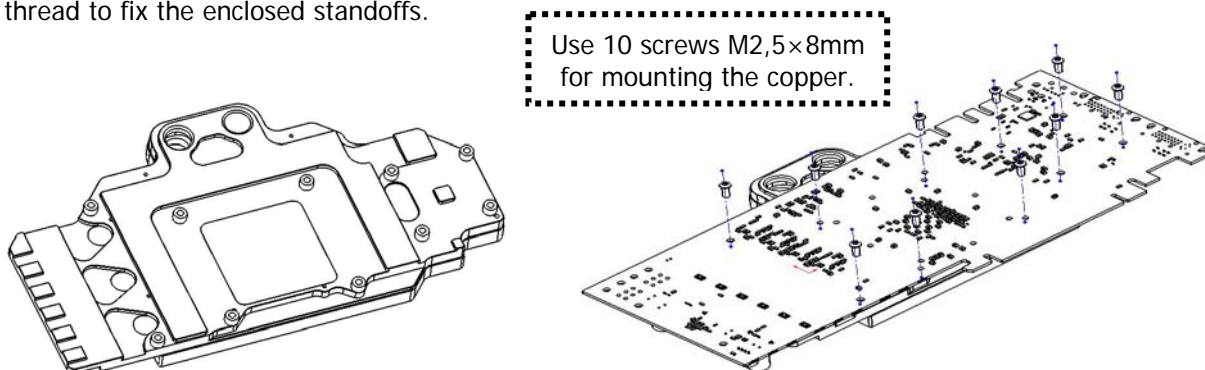

**Picture 7:** Placing/fixing the standoffs.

**Picture 8:** Mounting the water block with enclosed M2,5x8 screws.

**Step 5.** Start tightening the enclosed screws from the GPU (M2,5x8 screws) and continue outwards. Please make sure that spacers are well positioned and aligned with holes.

**Step 6.** Remove the block and check for contact surface. Then repeat steps from 3 to 6. If you are not using standoffs apply more or less pressure on area where you find it necessary.

**Step 7.** Attach the liquid cooling tubes and connect the water-block(s) into the cooling circuit. The EK-285GTX series are usually sold with high flow fittings. To ensure that the tubes are securely attached to the barb fittings, please use hose clamps or an appropriate substitute. The use of an algicide is always recommended for any liquid cooling system.

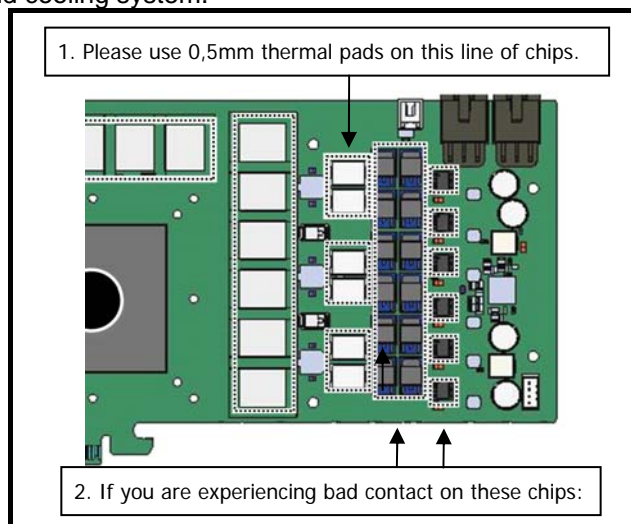

**VERY IMPORTANT NOTICE**

While all efforts have been made to provide the most comprehensive tutorial possible, EKWB assumes no liability expressed or implied for any consequential damage(s) occurring to your equipment as a result of using EKWB cooling products, either due to errors or omissions on our part in the above instructions, or due to failure or defect in the EKWB cooling products.

**IMPORTANT DISCLOSURES:**

While all efforts have been made to provide the most comprehensive tutorial possible, EKWB assumes no liability expressed or implied for any damage(s) occurring to your components as a result of using EKWB cooling products, either due to mistake or omission on our part in the above instructions, or due to failure or defect in the EKWB cooling products.

**WARRANTY:**

Our products are warranted against defects in materials or workmanship for a period of 24 months beginning from the date of delivery to the final user. During this period, products will be repaired or have parts replaced at our discretion provided that: (I) the product is returned to the agent from whom it was purchased; (II) the product has been purchased by an end user and has not used for commercial purposes; (III) the product has not been misused, handled carelessly, or used in a manner other than in accordance with the instructions provided describing its installation and proper use. This warranty does not confer rights other than those expressly set out above and does not cover any claims for consequential loss or damage. This warranty is offered as an extra benefit and does not affect your statutory rights as a consumer. **This warranty is voided if the product comes in contact with aggressive UV additives.**