

This product is intended for installation only by expert users. Please consult with a qualified technician for installation. Improper installation may result in damage to your equipment. EK Water Blocks assumes no liability whatsoever, expressed or implied, for the use of these products, nor their installation. The following instructions are subject to change without notice. Please visit our web site at [www.ekwb.com](http://www.ekwb.com) for updates. Before installation of this product please read important notice, disclosure and warranty conditions printed on the back of the box.

Before you start using this product please follow these basic guidelines:

1. Please carefully read the manual before through before beginning with the installation process!
2. Please remove your motherboard from the computer to assure safest mounting process in order to prevent any possible damages to your CPU and/or motherboard's circuit board (PCB).
3. The EK High Flow and EK-PSC type fittings require only a small amount of force to screw them firmly in place since the liquid seal is ensured by the rubber o-ring gaskets.
4. The use of corrosion inhibiting coolants is always recommended for any liquid cooling system.

## STEP 1: GENERAL INFORMATION ON PRODUCT COMPATIBILITY

Congratulations on your purchase of EK-Supremacy universal CPU water block. This water block is pre-assembled\* for use with modern AMD or Intel desktop socket type motherboards. By default this water block supports the following CPU sockets:

- Intel socket LGA-775, LGA-1155/1156, LGA-1366 and LGA-2011
- AMD socket S754/939/940, AMD AMx and FM1

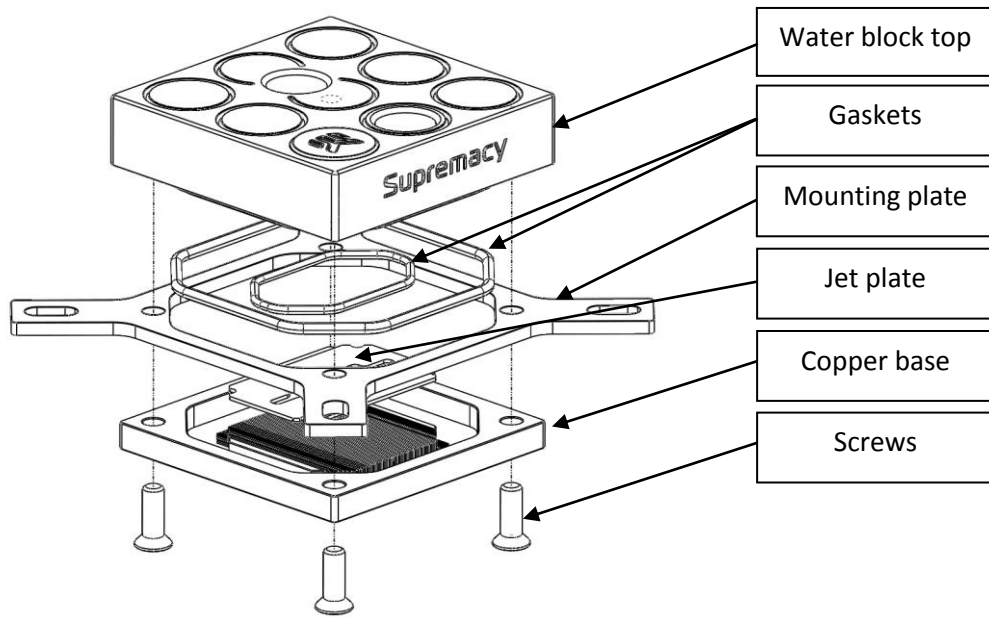

\*: depending on the variant. EK-Supremacy Elite Edition – AMD AMx & FM1 is shipped factory pre-assembled with AMD mounting plate.

**Caution:** Narrow server type LGA-2011 is not supported by default – a **Mounting plate Supremacy LGA-2011 Narrow ILM** (EAN: 3830046990600) is mandatory to install this water block on narrow server type LGA-2011 motherboards.

## STEP 2: TABLE OF CONTENT

The following items are enclosed with each EK-Supremacy water block:

- EK-Supremacy universal CPU water block
- **EK-TIM Indigo Extreme™** thermal interface material
- *PreciseMount* universal CPU mounting mechanism:
  - o M4 threaded thumb screws (4 pcs)
  - o Springs (4 pcs)
  - o M4 threaded thumb nuts (4 pcs)
  - o Washers (4 pcs)
- LGA-2011 M4 threaded mounting studs (4 pcs)
- Spare AMD / Intel mounting plate
- Backplate rubber gasket
- Backplate for Intel LGA-1366 and AMD socket motherboards
- Backplate for Intel LGA-115x socket motherboards
- Allen (hex) key 2.5mm
- Additional jet plates:
  - o Jet J2 (1.0mm thick) – optimized for LGA-1155/1156 CPUs
  - o Jet J3 (0.7mm thick) – optimized for LGA-2011 CPUs

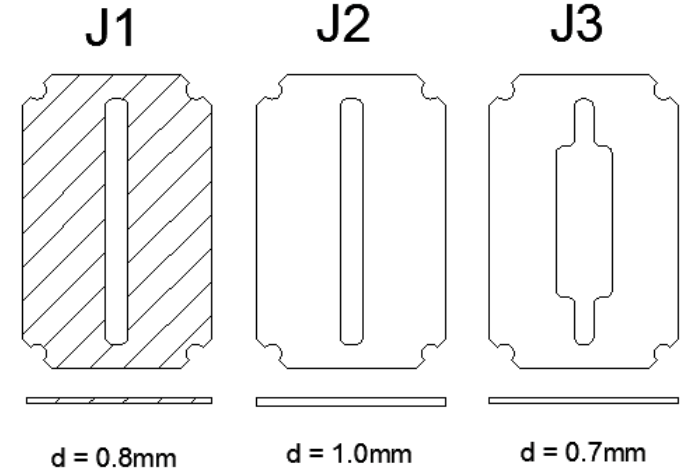

## STEP 3.1 (optional): INSTALLING AMD MOUNTING PLATE AND REPLACING JET PLATE PROCEDURE

1) Place water block on an even surface and remove the four M4x14 DIN7991 screws attaching the top to the copper base using the enclosed 2.5mm Allen key.

### 2) Replacing mounting plate:

- 2.1) Replace the Intel mounting plate with AMD one. You will feel the mounting plate locking into the position when placed correctly on to the top.
- 2.2) Reseat the larger o-ring gasket (57x2 mm) into the gap between the mounting plate and water block top. Skip to step #4 to complete installation.

### 3) Replacing jet plate:

3.1) Remove the default jet J1 (0.8mm thick) and replace it with jet J2 or jet J3, depending on your CPU platform. You will feel the jet plate locking into the position when placed correctly to the top. Reinstall smaller o-ring gasket if needed prior to replacing jet plate.

- 4) Carefully place copper base to waterblock top assembly, make sure gaskets stay in place! **Beware of copper base orientation!**
- 5) Repeat step #4 if necessary. Screw in all four (4) M4x14 DIN7991 screws using the enclosed 2.5mm Allen (hex) key.

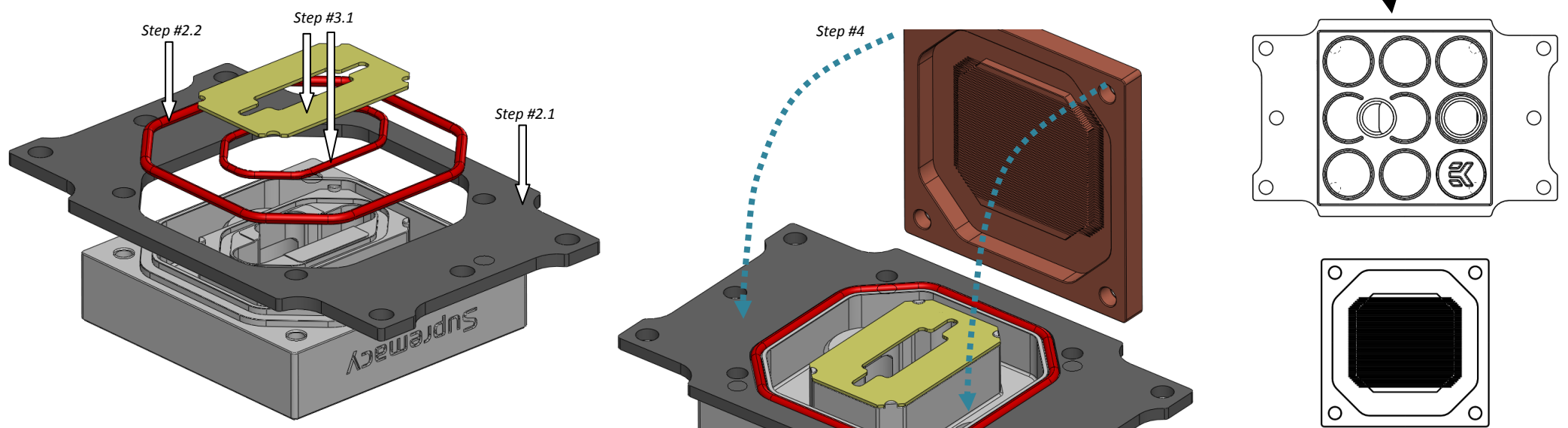

## STEP 4: PREPARING BACKPLATE RUBBER GASKET

The enclosed rubber gasket is essential part of the backplate and mounting system and must be used every time you install this water block. The rubber backplate has a partially cut inner part which needs to be removed when installed on Intel LGA-115x and LGA-2011 motherboard. The rubber is held on four places and can be peeled away with hand. These two pieces can be reassembled later if needed.

### Intel LGA-115x and LGA-1366 socket:

Remove the inner core of the rubber and use the outer part only.

### AMD sockets:

Use the whole rubber backplate including the inner core.

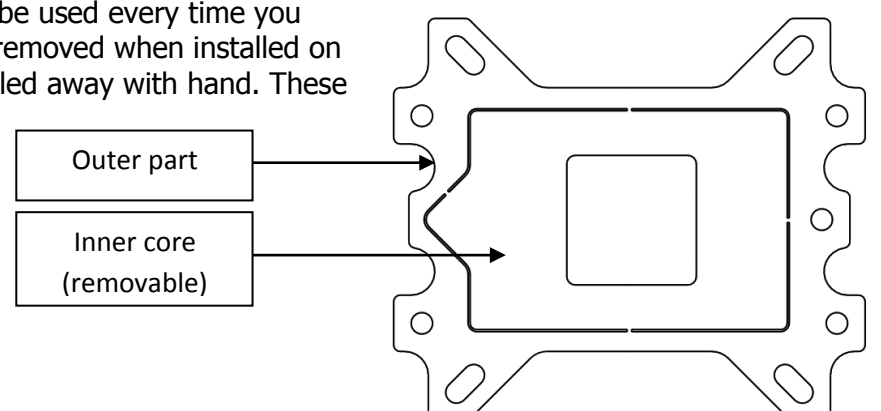

## STEP 5: INSTALLING THE WATER BLOCK:

### STEP 5a: Intel LGA-775, -1366 and AMD socket motherboard:

- 1) Place motherboard on an even surface with front facing down.
- 2) Install backplate rubber gasket - depending on your CPU platform (see STEP 4) - and place metal backplate for Intel LGA-1366 and AMD socket to the back of your motherboard. Align the holes on the motherboard with holes on rubber gasket and backplate.
- 3) Carefully rotate motherboard assembly with front side facing up with one hand while holding the backplate and rubber in place with the other hand.
- 4) Install the rest of mounting system as per installation manual (see STEP 6)

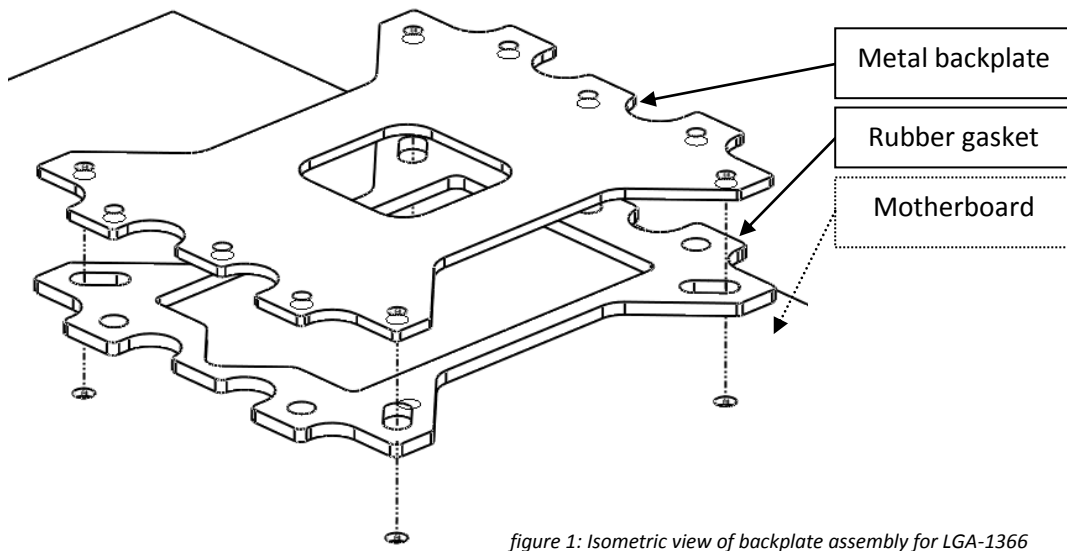

figure 1: Isometric view of backplate assembly for LGA-1366

### STEP 5b: Intel LGA-115x socket motherboard:

- 1) Place motherboard on an even surface with front facing down.
- 2) Install backplate rubber gasket - depending on your CPU platform (see STEP 4) - and place metal backplate for Intel LGA-115x socket to the back of your motherboard. Align the holes on the motherboard with holes on rubber gasket and backplate. **Make sure to orientate the rubber gasket to fit past the CPU socket ILM backplate.**
- 3) Carefully rotate motherboard assembly with front side facing up with one hand while holding the backplate and rubber in place with the other hand.
- 4) Install the rest of mounting system as per installation manual (see STEP 6)

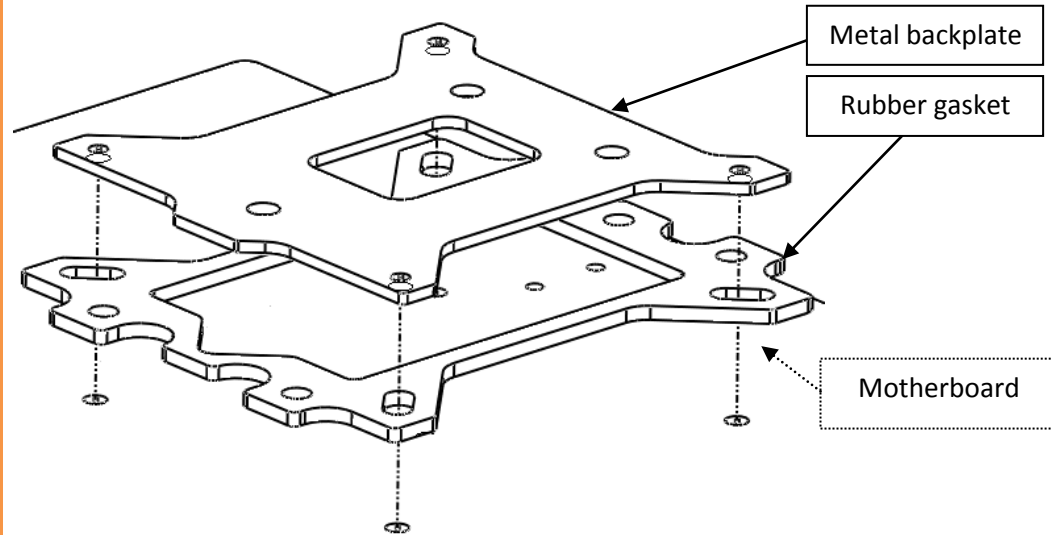

figure 2: Isometric view of backplate assembly for LGA-115x

### STEP 5c: Installing the mounting system:

#### Intel Socket LGA-115x/1366 and AMD sockets:

Install the M4 thumb screws of the PreciseMount mounting system onto your motherboard. It is mandatory to put 0.7mm plastic washer underneath each of the M4 thumb screws. Tighten the M4 thumb screw to the metal backplate with your hands until you reach the end of the thread. Using tools (such as pliers) is not recommended!

#### Intel Socket LGA-2011:

Install four (4) specific LGA-2011 M4 thumb screws into four M4 threaded stubs on the LGA-2011 socket integrated latch mechanism (ILM). The screws are to be installed using no tools (i.e. pliers).

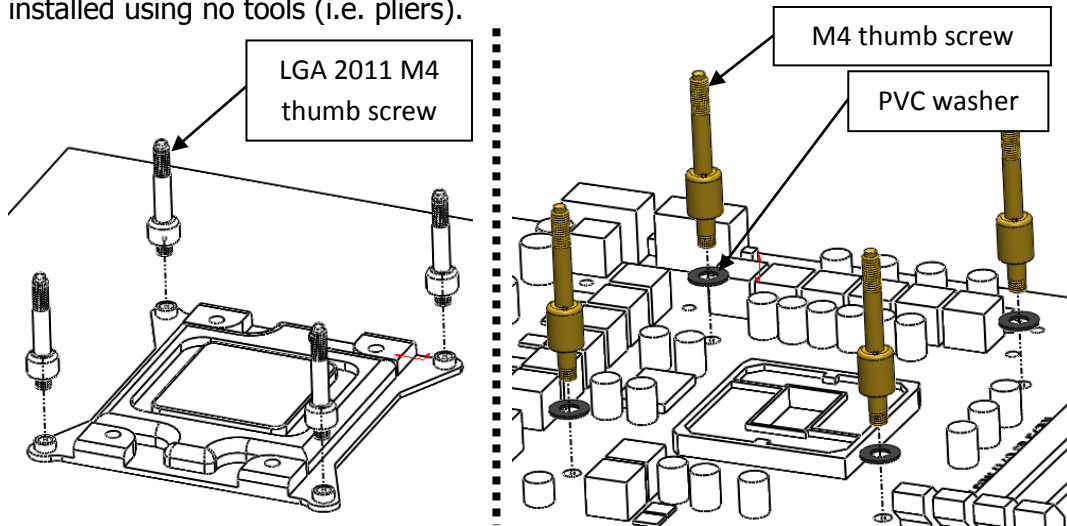

### STEP 5d: Preparing your CPU and applying EK-TIM Indigo Extreme:

Please consult the enclosed EK-TIM Indigo Extreme™ installation manual and install the thermal interface material as per installation manual. Improper installation may result in poor thermal properties of your EK-Supremacy Elite Edition series water block!

Remember, EK-TIM Indigo Extreme™ is not re-usable once reflow process is started.

**EK-TIM Indigo Extreme™ Installation Manual**  
for use with EK-Supremacy™ Series CPU Water Blocks

The product is intended for installation only by expert users. Improper installation may result in damage to your equipment. EK Water Blocks assumes no liability whatsoever, expressed or implied, for the use of these products, or their installation. The following instructions are subject to change without notice. Please visit our web site at [www.ekwatertech.com](http://www.ekwatertech.com) for updates. Before installation of the product please read important notes, disclosures, and warranty conditions printed on our home page.

**STEP 1: QUICK OVERVIEW**

**STEP 1.1: EK-TIM Indigo Xtreme™**  
Engineered Thermal Interface for Socket 1155 & 1156 (Intel Core™ i3, Core™ i5 and Core™ i7 processors)

Indigo Xtreme™ is an Engineered Thermal Interface (ETI) that fits neatly between a CPU lid and heat sink or water block to keep CPUs cooler. Unlike greases, metallic thermal interface pads or liquid metal alloys, Indigo Xtreme is a self-contained and sealed structure, deploying a Phase Change Metallic Alloy (PCMA) which reflows and fills surface defects on the CPU lid and heat sink. The resultant interfacial layer is void-free and robust, with low thermal contact and bulk resistance.

Important: Unlike most thermal interface products, the Indigo Xtreme form-factor is optimized for each application.

Attempting to use Indigo Xtreme with CPUs or water blocks other than those specified may result in degraded performance or interfacial failure (See: Supported Hardware).

**STEP 1.2: Compatibility List:**

**Supported Hardware:**

All EK-Supremacy series water blocks

**Supported Water Blocks:**

- Flood
- Acetal
- Full Copper
- Full Nickel

Prior to the installation and reflow of Indigo Xtreme, **do not disable** the Thermal Control feature that protects your CPU from overheating.

**STEP 1.3: ETI Kit Contents:**  
The Indigo Xtreme ETI is offered as part of an Engineered Thermal Interface Kit. This kit includes several cleanroom-grade surface cleaning products for (2) complete installations.

The ETI kit includes:

- Indigo Xtreme ETIs (2 installations)
- Cleanroom-grade dry wiper cloths
- Indigo Xtreme Clean™ (sample size)
- Pair of powder-free nitrile gloves
- Detailed Installation Guide

Check the condition of the ETI kit before installation; if any problem is found, contact EKWB for a replacement.

### STEP 5e: Fastening the waterblock:

Install the waterblock on your CPU. Place an enclosed compression spring and thumb nut over each M4 thumb screw. Start fastening two thumb nuts at a time, preferably in cross pattern and do not tighten them fully until all of them are partially screwed in. Then - using your fingers only - screw in all four thumb nuts until you reach the end of the thread.

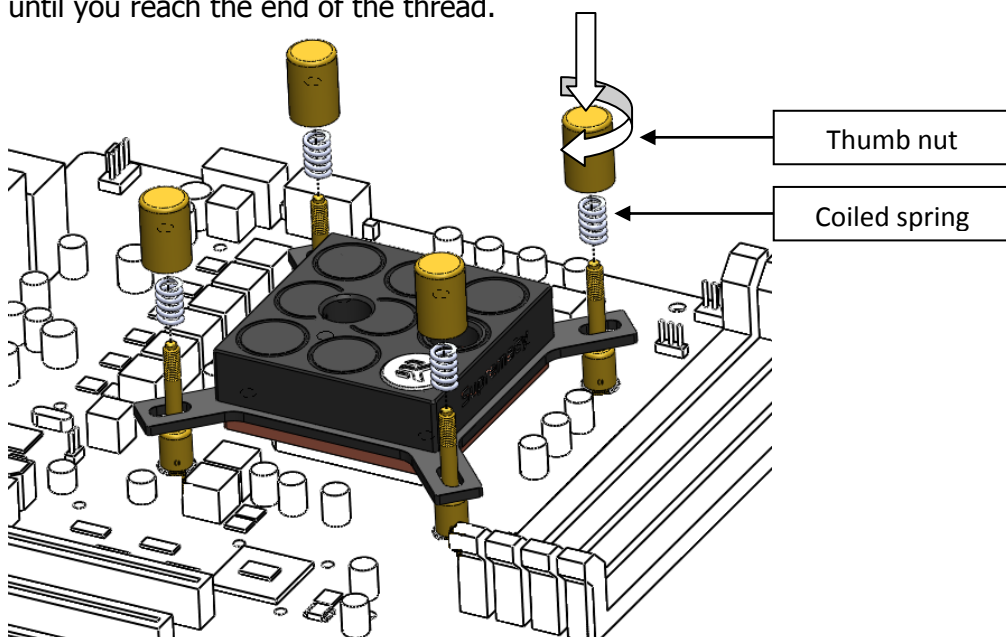

### STEP 6: CONNECTING WATER BLOCK TO THE COOLING CIRCUIT

Carefully identify the direction of the flow in your circuit. For the EK-Supremacy series water block to operate properly the G1/4 port nearest to the center of the water block **MUST BE USED AS THE INLET PORT**. EK recommends the use of EK-PSC fittings. When using fittings other than EK-PSC series please use hose clamps or appropriate substitute to secure the tubing to the barb. The use of biocide containing and corrosion inhibiting coolant is always recommended for any liquid cooling system.

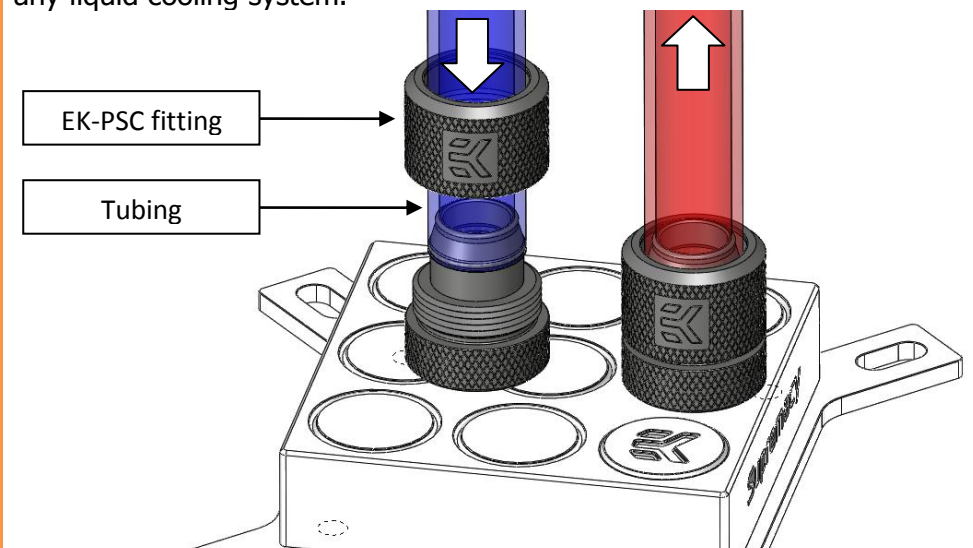

### REQUIRED TOOLS

- allen key 2.5mm (enclosed)



# EK-TIM Indigo Extreme™ Installation Manual

## for use with EK-Supremacy™ Series CPU Water Blocks

This product is intended for installation only by expert users. Improper installation may result in damage to your equipment. EK Water Blocks assumes no liability whatsoever, expressed or implied, for the use of these products, nor their installation. The following instructions are subject to change without notice. Please visit our web site at [www.ekwaterblocks.com](http://www.ekwaterblocks.com) for updates. Before installation of this product please read important notice, disclosure, and warranty conditions printed on our home page.

### STEP 1: QUICK OVERVIEW

#### STEP 1.1: EK-TIM Indigo Xtreme:

Engineered Thermal Interface for AMD FX,™  
Phenom,™ and Athlon™

Indigo Xtreme™ is an Engineered Thermal Interface (ETI) that fits neatly between a CPU lid and heat sink or waterblock to keep CPUs cooler. Unlike greases, metallic thermal interface pads or liquid metal alloys, Indigo Xtreme is a self-contained and sealed structure, deploying a Phase Change Metallic Alloy (PCMA) which reflows and fills surface defects on the CPU lid and heat sink. The resultant interfacial layer is void-free and robust, with low thermal contact and bulk resistance.

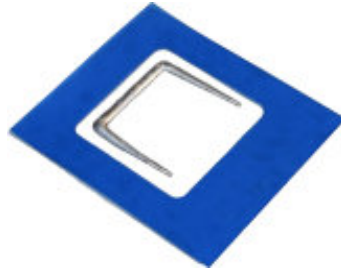

Important: Unlike most thermal interface products, the Indigo Xtreme form-factor is optimized for each application.



Attempting to use Indigo Xtreme with CPUs or water blocks other than those specified may result in degraded performance or interfacial failure (See: Supported Hardware).

#### STEP 1.2: Compatibility List:

##### Supported Hardware:

Supported CPUs: All lidded AMD FX,™  
Phenom™ and Athlon™ Processors

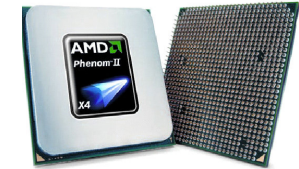

##### Supported Water Blocks:

All EK-Supremacy series water blocks

- Plexi
- Acetal
- Full Copper
- Full Nickel



Prior to the installation and reflow of Indigo Xtreme **do not disable** the Thermal Control feature that protects your CPU from overheating.

#### STEP 1.3: ETI Kit Contents:

The Indigo Xtreme ETI is offered as part of an Engineered Thermal Interface Kit. This kit includes several cleanroom-grade surface cleaning products for (2) complete installations.

The ETI kit includes:

- Indigo Xtreme ETIs (2 installations)
- Cleanroom-grade dry wiper cloths
- Indigo Xtreme Clean™ (sample size)
- Pair of powder-free nitrile gloves
- Detailed Installation Guide



Check the condition of the ETI kit before installation; if any problem is found, contact EKWB for a replacement.

### STEP 2: INSTALLATION PROCEDURE



**Read entire instructions before using EK-TIM Indigo Xtreme. Computer operating system and temperature monitoring utilities must be installed prior to use. Contact EKWB Support if you have any questions.**



**Prior to installing EK-TIM Indigo Xtreme, complete the water block assembly (thru Step 5C) as illustrated in the EK-Supremacy installation manual.**

#### STEP 2.1: Motherboard, CPU and Block Removal:

Remove the motherboard from the PC case. Remove the CPU from the motherboard socket and place on a non-abrasive, lint-free surface for cleaning. Motherboard removal will facilitate proper alignment of the ETI to the CPU lid and water block.

#### STEP 2.3: Put on Gloves:

Prior to the final degreasing step, the supplied powder-free nitrile gloves must be worn to prevent any finger oils or contaminants from contacting the CPU lid, water block and ETI surfaces and to prevent skin contact with Indigo Xtreme Clean.™

#### STEP 2.2: Thermal Interface Compound (grease) Removal:

Using the supplied dry wiper cloth, apply pressure to thoroughly remove any existing interface grease from the CPU lid and water block. Clean with fresh areas of the wiper cloth until no visible grease residue is detected on the wiper.



If removing metal pad or liquid metal TIM residue, refer to manufacturer's specific cleaning methods.



Stray grease compound can be mitigated as gloves are applied immediately following the Thermal Interface Compound Removal step.

### STEP 2.4: Degrease CPU lid and Water Block Surfaces:

Saturate a dry wiper cloth with Indigo Xtreme Clean™; use ~1/2 trial size bottle per ETI installation; thoroughly wipe the CPU lid; repeat with the water block interfacial surfaces. Continue to wipe each surface with fresh areas of the wiper until no visible residue is detected on the wiper. Wipe all surfaces of any visible lint, fibers, or particulates.



Be prepared to wipe the CPU lid and water block surfaces immediately upon saturating each dry wiper cloth as the Xtreme Clean™ solvent will quickly evaporate. New CPUs or water blocks must be degreased as well. Use only the supplied Indigo Xtreme Clean™ for the degreasing step.



Use the Xtreme Clean™ solvent in a well-ventilated area. Avoid contact with plastics (such as keyboards, computer cases, cooling fans, acetal and plexi water block housings, coolant tube fittings, cables, etc.). Also, avoid contact with elastomers (coolant tubing, gaskets, etc.).

### STEP 2.5: CPU Installation:

Install the CPU in the motherboard. Refer to motherboard or CPU installation instructions.



The ETI can only be applied after correct installation of the CPU.

### STEP 2.6: Indigo Xtreme Handling:

The Indigo Xtreme ETI may be handled on the blue surfaces only.



ETI installation requires a lint-free environment.



Do not remove the clear Top and Bottom liners prior to the specific installation step. Do not bend, flex or puncture any portion of the ETI. Keep all chemical agents (Indigo Xtreme Clean™, etc.) away from the ETI.

### STEP 2.7: Bottom Side Liner Removal:

Remove the "Bottom" side rectangular clear liner by slowly peeling the liner, beginning from the corner with the white BOTTOM" label. Hold the ETI on the blue edges (with both hands to prevent any wrinkling or warping) Do not remove the "Top" liner at this step.



Do not touch the exposed adhesive area after removal of the clear liner. Once the liner has been removed, proceed immediately to Step 2.8: Alignment and Placement.

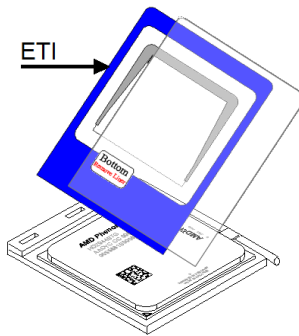

### STEP 2.9: Top Side Liner Removal:

Remove the "Top" side rectangular clear liner by slowly peeling the liner, beginning from the corner with the white "TOP" label.



Do not touch any of the clear surfaces after removal of the clear liner. Once the liner has been removed, proceed immediately to Step 2.10: Water Block Mounting.

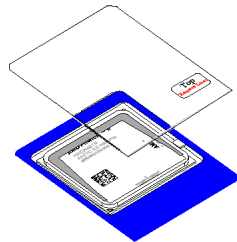

### STEP 2.8: Alignment and Placement:



Orientation and alignment of the ETI to the CPU lid and socket is critical. Orient the ETI such that the Bottom side is facing the CPU lid. Refer to the figures for correct placement.

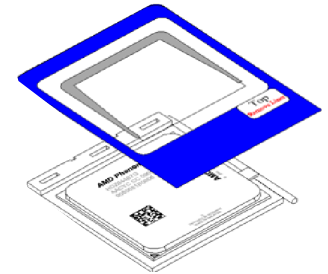

Hold the ETI on the blue edges (with both hands to prevent any wrinkling or warping). Ensure that the ETI is oriented with CPU lid/socket as shown. Align the square blue ring to the edge of the CPU lid before making contact. Carefully lower the ETI onto the CPU lid surface. With moderate, downward finger pressure, completely press down all ETI surfaces onto the CPU lid by following the square blue alignment ring.



It is critical that the square blue alignment ring is completely on the CPU lid and all blue ring surfaces are thoroughly pressed down.

### STEP 2.10: Water Block Mounting:

Use the following mounting instructions to ensure optimal clamping force on the ETI:

1. While holding the water block in a level/horizontal position, place the springs onto each thumb screw.
2. Place thumb nuts on each screw and turn just enough to engage the threads.
3. Temporarily mark each thumb nut with a marking pen or tape to indicate the starting position (see the black markings illustrated on the top of each thumb nut in the image).
4. Turn all thumb nuts four (4) full revolutions, beginning with the upper left and right thumb nuts (as illustrated in the image).
5. Proceed to Step 3: ETI Reflow Procedure.

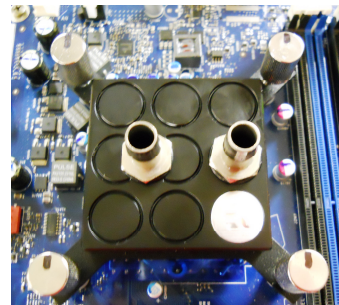

It is imperative that the water block is aligned correctly before it makes contact with the ETI. Avoid any twisting on the ETI as the water block is bolted down.



Be certain thumb nuts have been tightened only (4) full revolutions (from initial thread engagement); DO NOT fully tighten thumb nuts; excessive clamping force may damage ETI, resulting in alloy leakage and/or poor thermal performance.

### STEP 3: ETI REFLOW PROCEDURE:

#### ETI Reflow:

As part of installation, the Indigo Xtreme ETI must first be heated with the CPU running under load in order to reflow (melt) the PCMA.



The interface is highly thermally resistive without a complete reflow. Failure to perform the exact reflow procedure may result in unacceptable thermal performance. A video demonstration of ETI reflow can be found at EKWB product page: <http://www.ekwb.com>

1. Connect up all liquid lines to the water block.
2. Orient the computer such that the motherboard and CPU are in a horizontal position.
3. Turn on the liquid pump.
4. Boot the computer. Clock frequency and voltage must be set to default (stock).
5. Use a CPU temperature monitoring program (such as SpeedFan™) and select the graphing option to track the profile of all core temperatures during reflow. Be certain the graph is open with all core temperatures selected before proceeding to the next step.
6. With the computer running, turn off the liquid pump.
7. Exercise the CPU with a "burn" program (such as Prime 95™) to generate adequate heat for reflow. Multi-core CPUs require one open copy of the burn program for each core.
8. Follow the average core temperature profile (with SpeedFan) illustrated in the graph and corresponding tables below for your particular water block.  
Full copper/nickel water blocks will require longer reflow times.

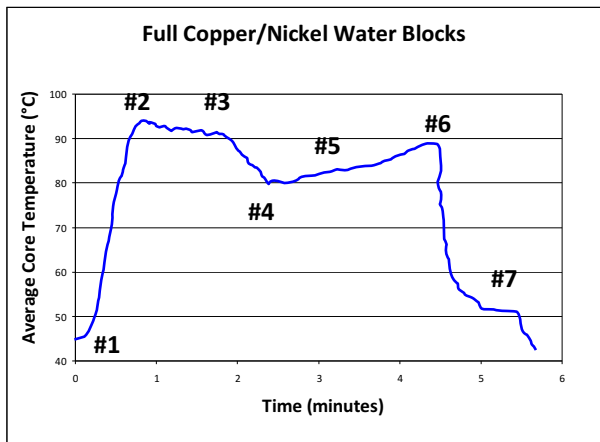
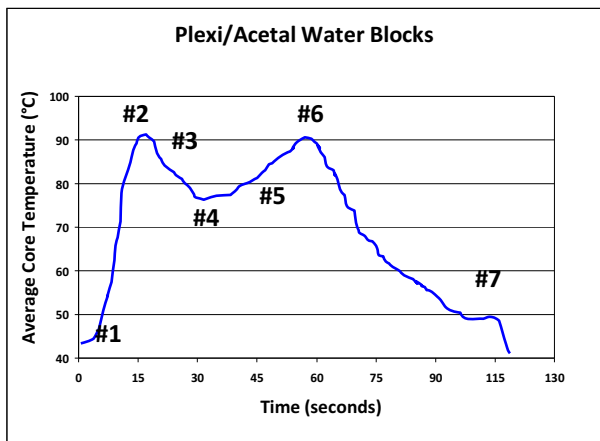

#	Plexi/Acetal Water Blocks	Full Copper/Nickel Water Blocks
1	All burn programs have been activated and liquid pump has been turned off.	All burn programs have been activated and liquid pump has been turned off.
2	Core temperatures will immediately rise to peak of ~80-90°C.	Core temperatures will immediately rise to peak of ~80-90°C.
3	Core temperatures will quickly descend within seconds of activating burn programs.	Core temperatures will somewhat stabilize for a few minutes and then slowly descend.
4	All core temperatures will drop to a Bottoming Point (lowest temperature).	All core temperatures will drop to a Bottoming Point (lowest temperature).
5	Following the Bottoming Point, average core temperatures will slowly rise again.	Following the Bottoming Point, average core temperatures will slowly rise again.
6	Once the average core temperature has reached ~80-85°C, de-activate all burn programs.	Once the average core temperature has reached ~80-85°C, de-activate all burn programs.
7	All core temperatures will again drop to the second Bottoming Point. Once the lowest temperature is reached, turn on liquid pump.	All core temperatures will again drop to the second Bottoming Point. Once the lowest temperature is reached, turn on liquid pump.



Intel multi-core processors have built-in protection (Adaptive Thermal Monitor) that prevents the processor from exceeding maximum core temperatures, thereby preventing any damage to the CPU.



Avoid any bumping or excessive pressure on the heat sink/waterblock and keep the computer in the horizontal position until the average core temperature has dropped below 60°C.



If the average core temperature does not follow a similar temperature profile as seen in the previous graphics, then improper reflow may have occurred. Proceed to "Removal" and re-install a new ETI.

## REMOVAL OF EK-TIM INDIGO XTREME:

To disassemble, loosen the water block thumb nuts. The ETI may then be removed (intact) by first slowly peeling each corner. The ETI is designed to adhesively capture excess alloy (from differences of CPU lid/heat sink interfacial roughness and planarity) on their surfaces. Any residual adhesive on the CPU or water block may be removed with the edge of a credit card and with Xtreme Clean, acetone, or xylene on a clean wiper or cotton cleaning swab. Residual alloy is best removed by wetting the supplied swab with Xtreme Clean and gently rotating the swab to loosen and collect the alloy particles.



Indigo Xtreme is a single-use interface product and any removal of the water block (pre/post-reflow) will require a new ETI. All interface material and adhesive residue must be removed and the CPU and water block re-cleaned (with the surface cleaning supplies including in the ETI kit only) prior to the re-installation of a new ETI.

## REFERENCES:

**Burn in program:** IntelBurnTest: <http://www.softpedia.com/get/System/Benchmarks/IntelBurnTest.shtml>

**Temperature monitors:** Motherboard manufacturers usually supply a hardware monitor utility for their boards. CPUID.org's HWMonitor (Pro) or SpeedFan are the most popular temperature monitoring tool. It includes a real-time graphing mode that will aid in the monitoring of the processor burn-in: <http://www.almico.com/speedfan.php> ; <http://www.cpuid.com/softwares/hwmonitor.html>

The Material Safety Data Sheet (MSDS) for Indigo Xtreme Clean™ can be found at: [http://www.ekwaterblocks.com/shop/EK-TIM/MSDS\\_Indigo.pdf](http://www.ekwaterblocks.com/shop/EK-TIM/MSDS_Indigo.pdf)

Contact us for more information about this or other EK-TIM Indigo Xtreme applications at our website: <http://www.ekwb.com>

Store EK-TIM Indigo Xtreme at room temperature conditions of 22°C (72°F) and 50% R.H., preferably in the original sealed enclosure and plastic bag.

## DISCLAIMER:

EKWB d.o.o. and Enerdyne Solutions are not responsible for any damages due to external causes, including but not limited to, improper use, accident, neglect, alteration, repair, improper installation, improper testing, or damages caused by overclocking.

AMD FX,™ Phenom,™ and Athlon™ are trademarks of Advanced Micro Devices, Inc., USA.

EK-Supremacy is a trademark of EKWB d.o.o

Indigo Xtreme is a trademark of:

Enerdyne Solutions, Inc.,

125 West North Bend Way, PO Box 2660,

North Bend, WA., 98045 United States of America

