



Product Specification Sheet

EK-FC285 GTX Rev.2 PCB

EAN / Part #: 3830046993946

Copper Plexi

Copper Acetal

Nickel Plexi

Nickel Acetal

Summary:

- Featuring a unique, modern look copper design High performance VGA water block for GeForce 285 GTX reference design series graphic cards.
- EK FC series water blocks cover all chips on graphic cards that require cooling if overclocked.
- An extreme high flow path design and unique increased cooling surface over GPU keeps all your graphic cards components cool even at highest graphical loads and over clock.
- Blocks base is made of SE CU electrolytic copper.
- High quality CNC manufacturing.
- Tested to seal to up to 2 bars.
- Safe, noob-proof mounting system with Standoffs.

Key Features:

- Real high flow internal design gives minimum flow restriction which allows lowest possible temperatures, not only at VGA water block, but also in the entire water-cooling system.
- Cools GPU, VREG, I/O CHIPS and MEMORY modules.
- Multiple barb/fitting position allows 4 different fitting configurations. Allows maximum flexibility for water cooling system setup also in SLI, 3-SLI and Quad-SLI.
- Reduces temperatures up to 50°C or more at maximum load.
- Much cooler components allow maximum possible overclocking.

Technical data:

- dimensions of copper base: 217 x 118 x 8mm
- dimensions of acetal top: 174 x 119 x 8mm
- threads: 4 x G 1/4
- fittings: optional, not enclosed
- neto weight: 950g
- bruto weight: 1070g

Packing list:

- 1 x Water block
- 2 x EK-Plug G 1/4
- 2 x EK-G 1/4 Spacer with o-ring
- Mounting mechanism with 10 x POM Acetal standoffs
- Thermal pads



Do not forget other EK products for your water cooling system:



blocks



radiators



pumps



resevoirs



accessories

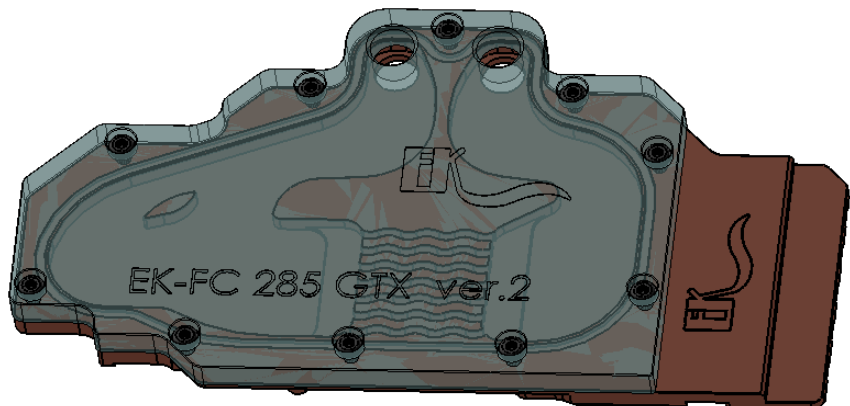
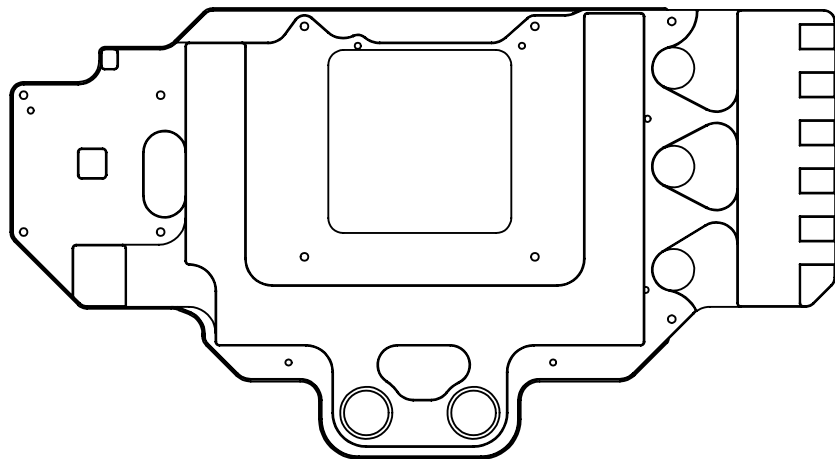
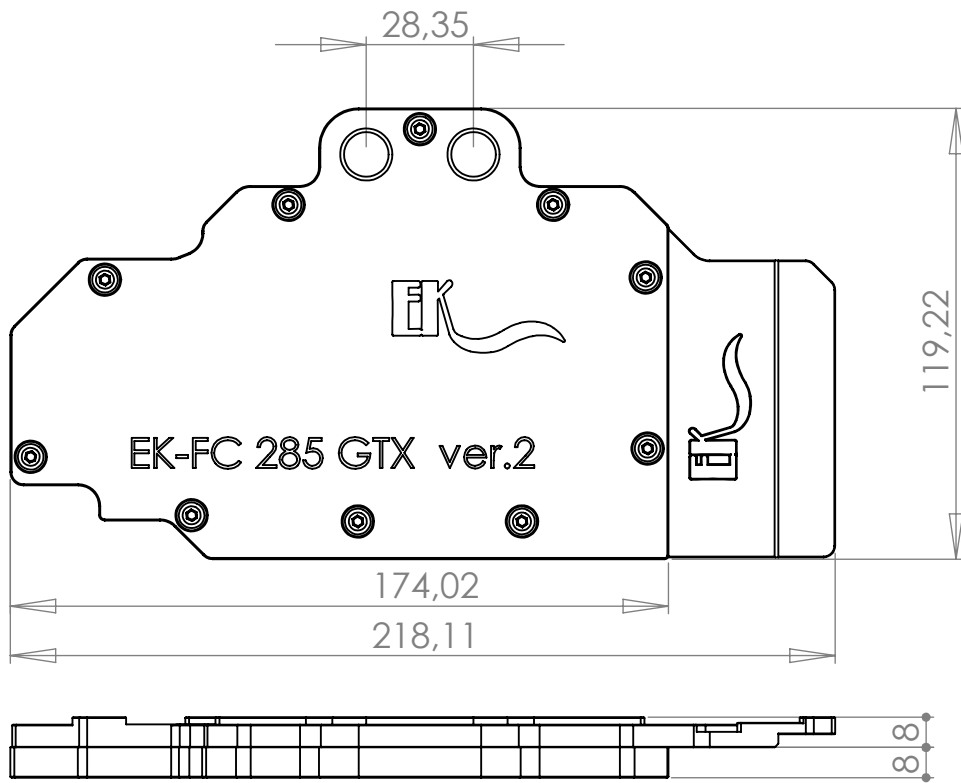

IMPORTANT DISCLOSURE: Drawing is copyrighted and property of EKWB d.o.o. company. Drawing is supplied only for easier compatibility recognition by user and can not be used for any other intention.



PRODUCT NAME: **EK-FC285GTX VER.2**

Scale: **1:2**

Sheet format A4

Sheet 1 of 1