



Product Specification Sheet

EK-FB RE2

EAN / Part #: 3830046991355

Copper Plexi

Copper Acetal

Nickel Plexi

Nickel Acetal

Summary:

- Featuring a unique, modern look copper design High performance Full Board water block for Rampage II Extreme motherboard.
- An extreme high flow path design and unique increased cooling surface over Northbridge and Southbridge keeps all your motherboard components cool even at highest loads and over clock.
- Blocks base is made of SE CU electrolytic copper.
- High quality CNC manufacturing.
- Leak tested to 2 bar pressure (30psi).
- Safe, noob-proof mounting system.

Key Features:

- Real high flow internal design gives minimum flow restriction which allows lowest possible temperatures, not only at FB water block, but also in the entire water-cooling system.
- Cools NB and SB.
- Allows maximum flexibility for water cooling system setup also in SLI/FC..
- Reduces temperatures up to 40°C or more at maximum load.
- Much cooler components allow maximum possible overclocking.

Technical data:

- dimensions of copper base NB/SB: 134 x 105 x 5mm
- dimensions of acrylic top NB/SB: 123 x 145 x 8mm
- threads: 2 x G 1/4
- fittings: optional, not enclosed
- neto weight: 250g
- bruto weight: 320g

Packing list:

- 1 x Water block
- Mounting mechanism with 6 washers
- Thermal pads



Do not forget other EK products for your water cooling system:



blocks



radiators



pumps



resevoirs



accessories

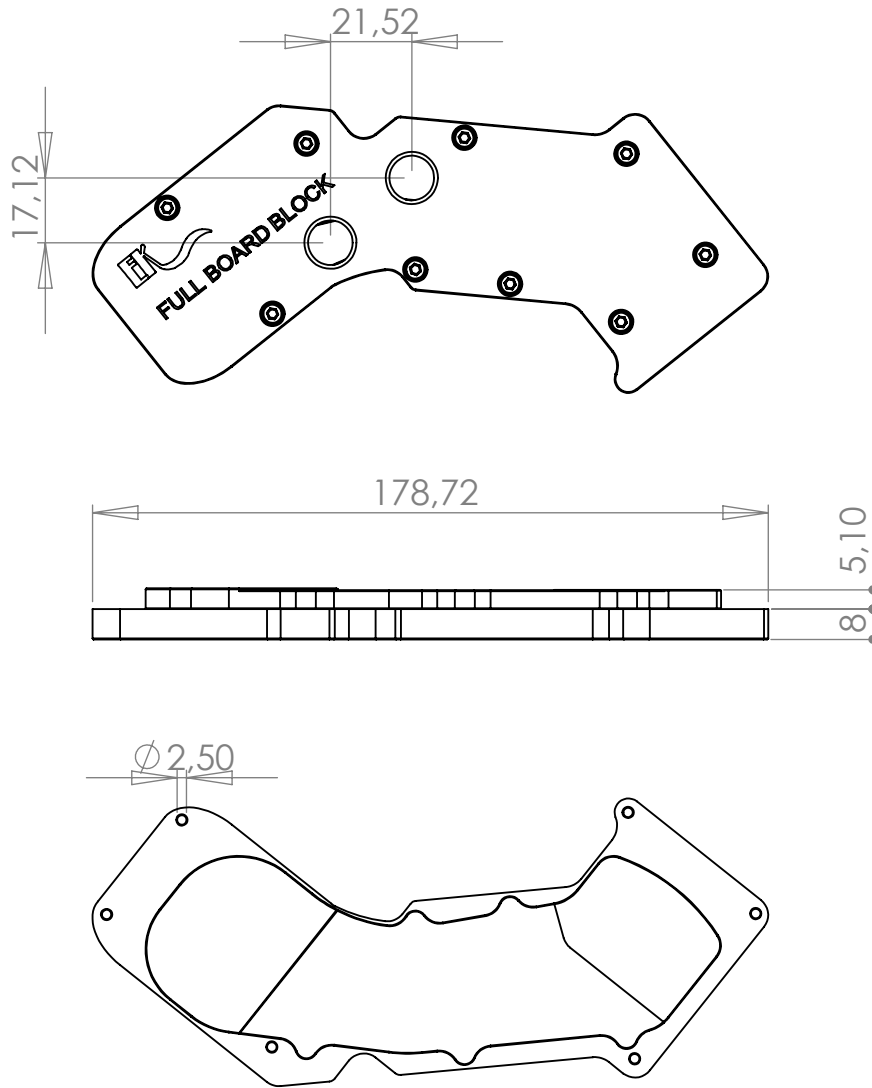

IMPORTANT DISCLOSURE: Drawing is copyrighted and property of EKWB d.o.o. company. Drawing is supplied only for easier compatibility recognition by user and can not be used for any other intention.



PRODUCT NAME: **EK-FB STRIKER II EXTREME**

Scale: **1:2**

Sheet format A4

Sheet 1 of 1