



Installation and mounting manual for **EK-FB ASUS M5E** water block:

This product is intended for installation only by expert users. Please consult with a qualified technician for installation. Improper installation may result in damage to your equipment. EK Water Blocks assumes no liability whatsoever, expressed or implied, for the use of these products, nor their installation. The following instructions are subject to change without notice. Please visit our web site at www.ekwb.com for updates. Before installation of this product please read important notice, disclosure and warranty conditions printed on the back of the box.

Before you start using this product please follow these basic guidelines:

1. **Please carefully read the manual before through before beginning with the installation process!**
2. **Please remove your motherboard from the computer to assure safest mounting process in order to prevent any possible damages to your CPU and/or motherboard's circuit board (PCB).**
3. **The EK High Flow and EK-PSC type fittings require only a small amount of force to screw them firmly in place since the liquid seal is ensured by the rubber o-ring gaskets.**
4. **The use of quality, market proved corrosion inhibiting coolants is always strongly recommended for any liquid cooling system.**

STEP 1: GENERAL INFORMATION Sample photo of ASUS Maximus V Extreme motherboard



STEP 2: PREPARING YOUR MOTHERBOARD

1. **REMOVING STOCK COOLER.** Remove all encircled screws. There are 10 screws on the back of the motherboard that needs to be removed in order to remove the factory installed MOSFET- as well as NB/SB heatpipe cooling solution.

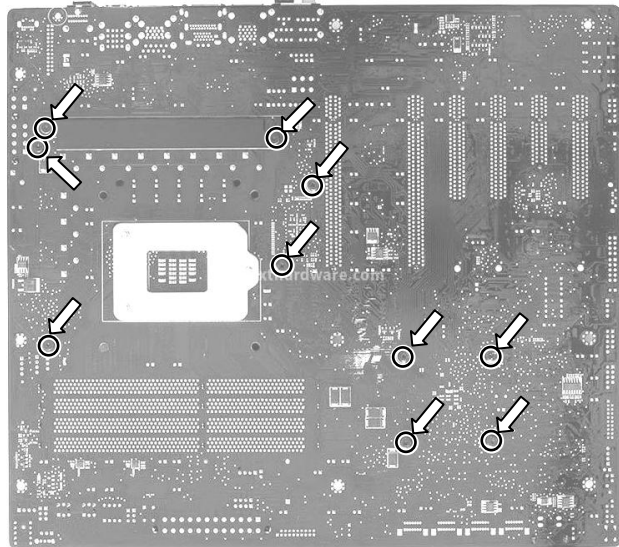

2. **CLEANING THE PCB.** Carefully detach the original stock cooler after removing **all** screws securing it to the board. Wipe off the remains (by using non-abrasive cloth or *qtip*, as shown on sample photo) of the original thermal compound until the components and circuit board are completely clean. EKWB recommends the use of denatured alcohol for removing TIM leftovers.

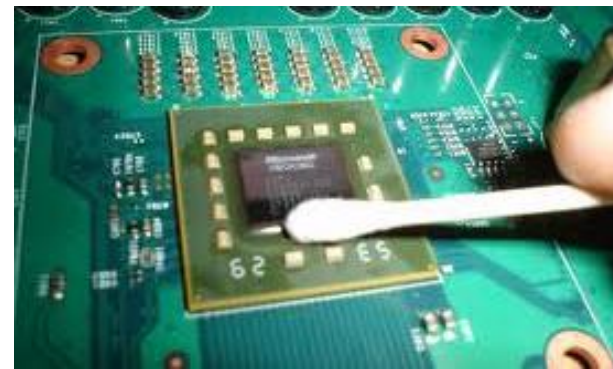

3. **APPLYING THERMAL COMPOUND.** Apply thermal compound: lightly coat the *Intel Z77 PCH (SB)* as well as *PLX PEX 8747* with electrically non-conductive thermal grease - for example Arctic Cooling MX-2™, MX-4™ or GELID GC-Extreme™. EKWB recommends to apply thermal grease in cross form for best performance (see sample picture).

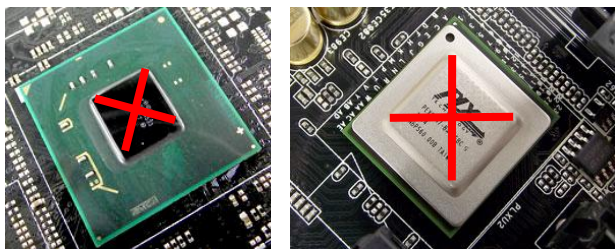

4. **CUTTING THERMAL PADS.** Your block comes with two thermal pads which needs to be trimmed in order to fit the voltage regulation area (VRM/MOSFET) on the motherboard's circuit board. **WARNING: DIMENSIONS ON PICTURES BELOW ARE SCALED!**

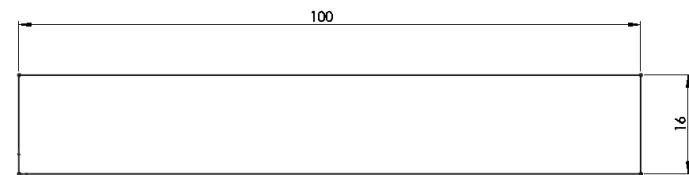

Replacement thermal pads @ EKWB web shop:
Thermal PAD A 1,0mm - (100x16mm) [EAN: 3830046996626]

5. **PLACING THERMAL PADS ON MOTHERBOARD.** Place thermal pads you cut on PCB as shown on picture below (PLEASE REMOVE THE PROTECTIVE FOIL FROM BOTH SIDES OF THE THERMAL PADS PRIOR TO INSTALLATION). EK recommends using small drops of electrically non-conductive (for example: Arctic Cooling MX-2™, MX-4™ or GELID GC-Extreme™) thermal grease on each phase regulator (that is being covered with thermal pad; see picture below) in order to even further improve the thermal performance of the EK-FB ASUS M5E series water block.

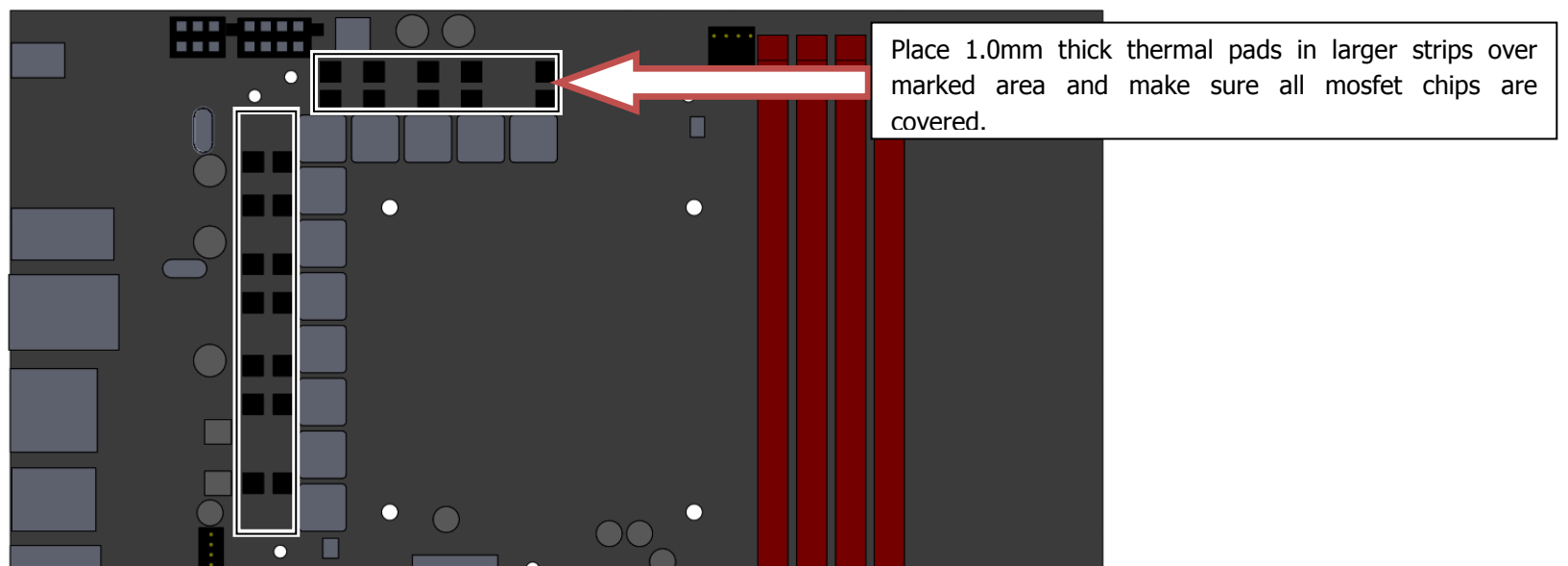

STEP 3: PREPARING YOUR WATER BLOCK

1. PLACING SB BLOCK ON MOTHERBOARD. Place the EK-FB ASUS M5E series water block with pre-installed 2.1mm standoffs kit gently to the motherboard or vice versa. Make sure that mounting holes are aligned.

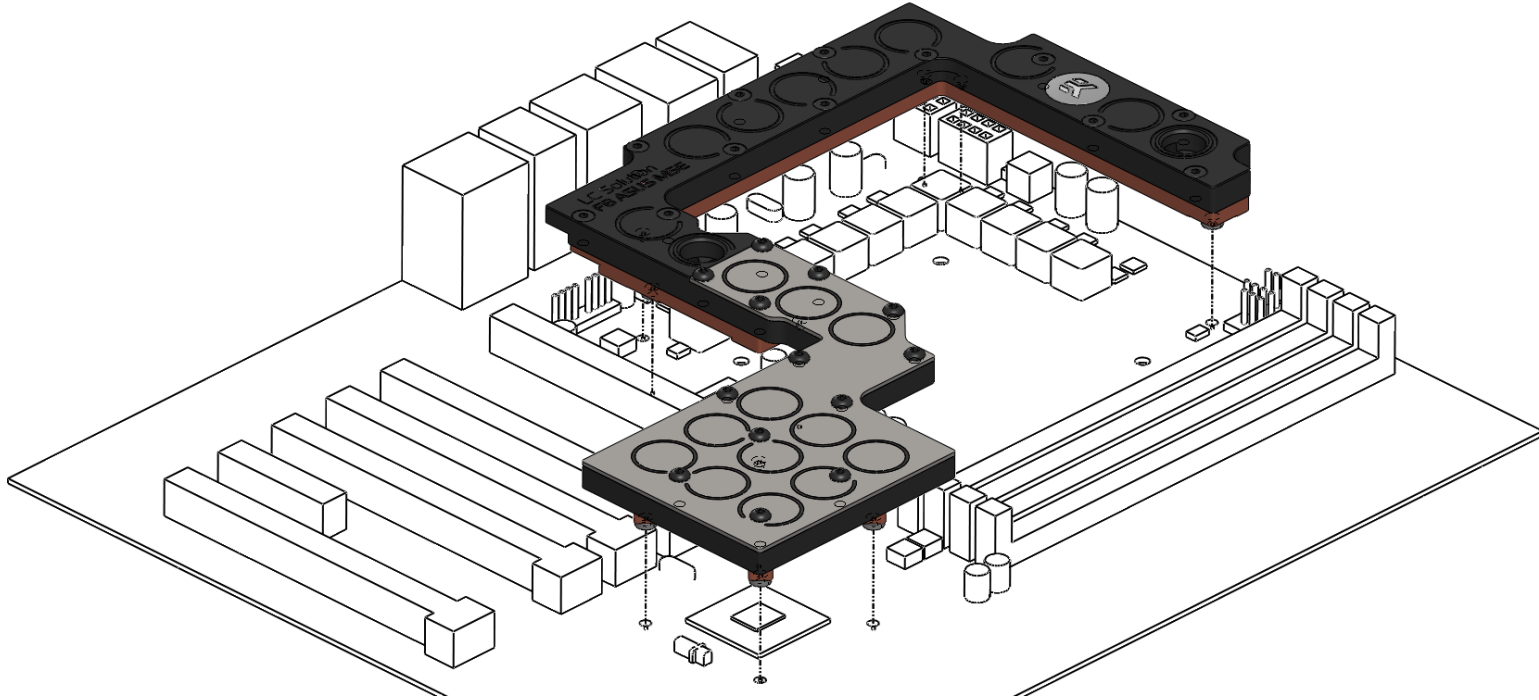

STEP 4: ATTACHING BLOCK TO MOTHERBOARD

Prior to fastening the screws please make sure the mounting holes on the motherboard's circuit board are aligned with water block.

Use eight M2.5x4 DIN7985 and washers: Tighten the screws, beginning near the center of the board and continue evenly outwards. Do not use excessive force when tightening the screws!

Re-use ASUS factory ("stock") backplate and two M2.5x8 to secure the last two mounting positions. Use the enclosed screws and washers as shown in picture below:

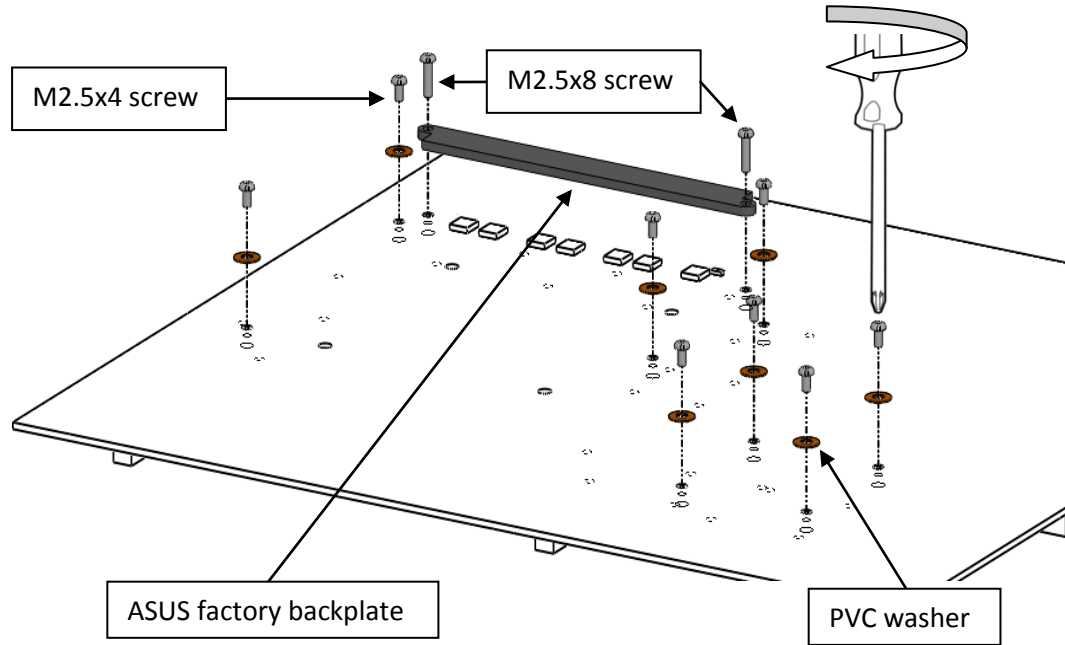

STEP 5: CHECKING FOR CONTACTS

Temporarily remove the water block to check for uniform surface contact between the block and the components. Note the pattern of contact on a piece of paper. Then repeat steps 3 and 4 to reattach the block applying more or less pressure to the areas where you have found it necessary. Note that there is no need for perfect thermal pad imprint on the inductors/coils (mentioned in STEP2)

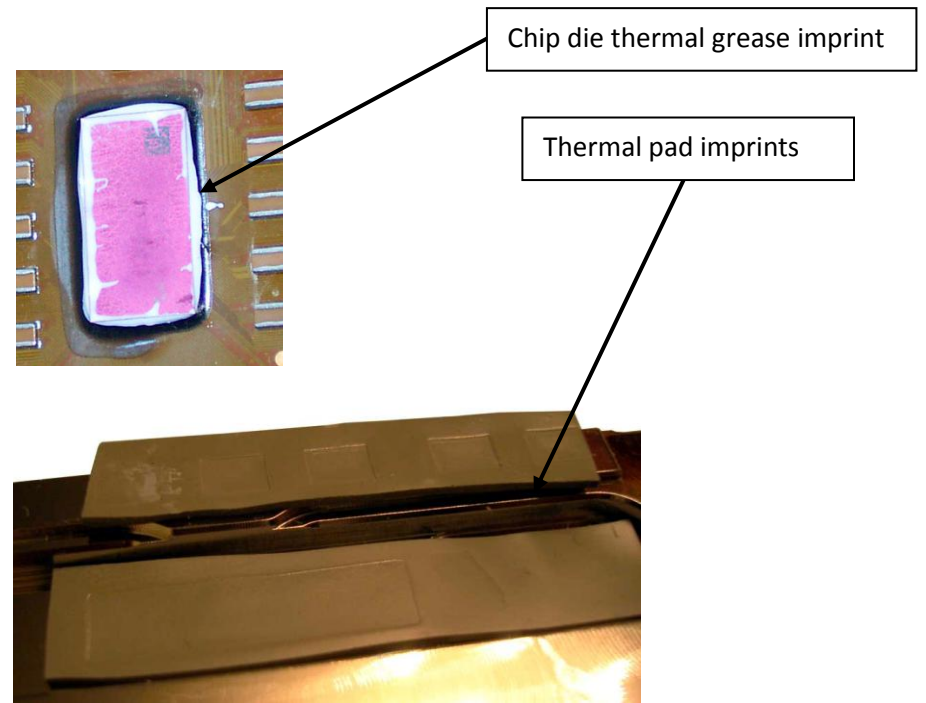

6. POSITIONING FITTINGS AND CONNECTING TO WATER CIRCUIT

Attach the liquid cooling tubes and connect the water-block(s) into the cooling circuit. EKWB recommends using EK-PSC compression fittings with the EK-FB ASUS M5E series water block. You can use any opening as an inlet/outlet port. Plan your tubing routing in advance!

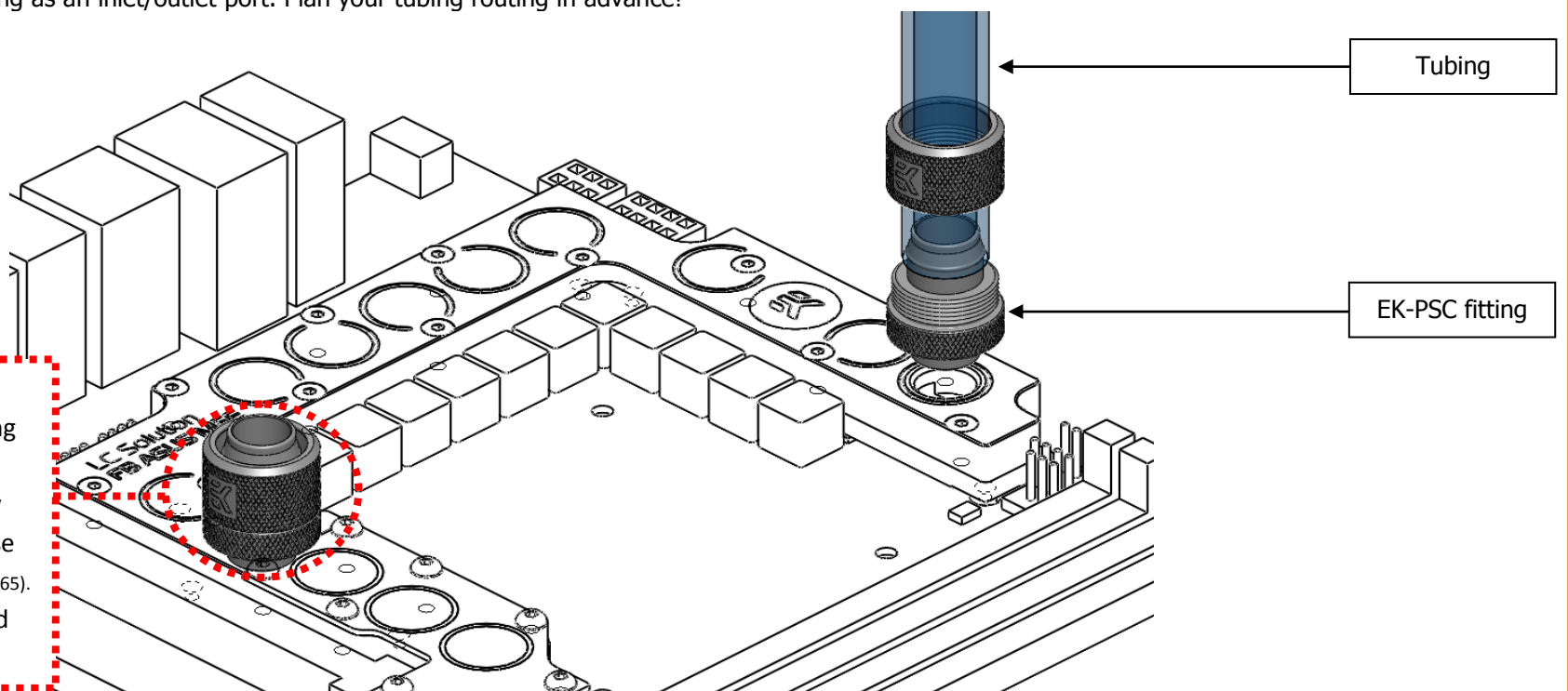

PLEASE NOTE: The largest compatible fitting is EK-PSC Fitting 12mm. In order to use EK-PSC Fitting 13mm (or larger 3rd party connectors) it is mandatory to use EK-Extender G1/4 (EAN: 3831109845165). This extender is **not enclosed** and must be purchased separately!

REQUIRED TOOLS AND MOUNTING SCREWS:

