



4th revision, Jan 20th 2016

Supremacy MX – AMD®

USER GUIDE

GENERAL INFORMATION ON WATER BLOCK COMPATIBILITY

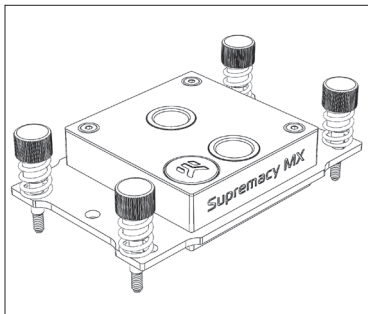

This CPU liquid cooling unit is pre-assembled for use with modern AMD® desktop socket type motherboards. By default this water block supports the following CPU sockets:

-AMD® socket AMx and FMx

AMx and FMx SOCKET MOTHERBOARDS

STEP 1

Place the motherboard on a even surface with front side facing up.

Using Philips-head screwdriver remove the four UNC 6-32 screws securing the original plastic hold-down clamps around the socket as shown on the picture.

Keep original AMD backplate in place!

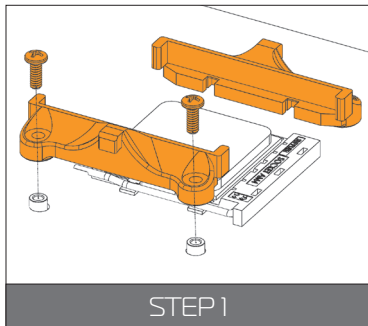

STEP 1

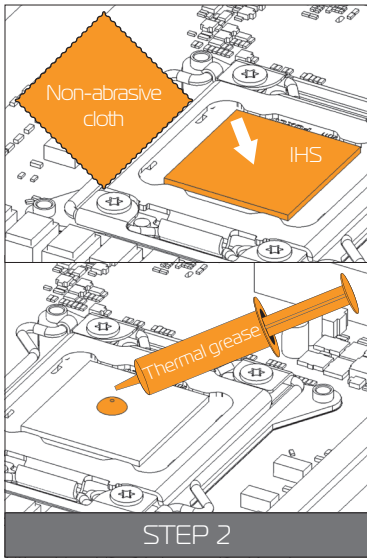

STEP 2

Cleaning the CPU: Wipe the CPU's contact surface (by using non-abrasive cloth or Q-tip, as shown on sample photo).

Applying thermal compound: EK recommends blob or line method of applying the enclosed thermal compound to the CPU heat spreader (IHS) - see sample photo on right.



The quantity of about two rice grains is just about right.
There is no need to cover the whole IHS. Applying too much thermal grease will have negative impact on the cooling performance!

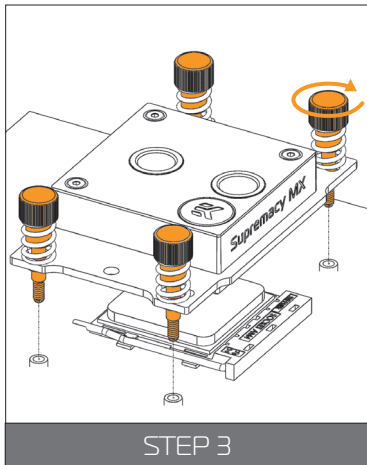

STEP 3

Align water block with pre-installed mounting mechanism above the AMD® socket motherboard with pre-installed CPU and original AMD® backplate.

Tighten the screws with your thumbs until you reach the end of the thread, preferably by tightening two thumb screws at a time in the cross pattern. Do not use any tools (such as pliers) during this process!

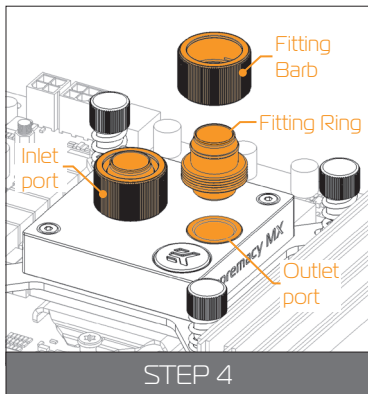

STEP 4

Tighten the fitting barbs in clockwise direction until the gasket underneath is compressed.

The installation of the CPU water block is now complete.



With EK-Supremacy MX series water blocks it is mandatory to use the port that is nearest to the center of the water block as INLET port. Mixing the ports may result in less than ideal thermal performance of the water block.